

AIR-C24

Passive installation speaker



AIR-C series sets a new standard for small-format permanent installations for retail, entertainment, malls, and club settings. With a rich Hi-Fi sound quality and solid SPL performance AIR-C speakers are nevertheless compact, easy to install and tune, and fully customizable.

The secret of the series' ultimate performance is low distortion high-performing transducers and a proprietary Polycomp® wood/polyurethane composite cabinet technology. It allowed for the special cabinet form that eliminates internal standing waves. Not only that, the composite dramatically reduces the cabinet resonances itself, bringing clarity and intelligibility to a whole new level.

With a small visual footprint, the AIR-C24 is a high-performing system with two 4" woofers and an HF driver on a rotatable horn. It is compatible with horizontal and vertical adjustable mountings and is available in 8 Ohm for ease of parallel usage.



DIMENSIONS

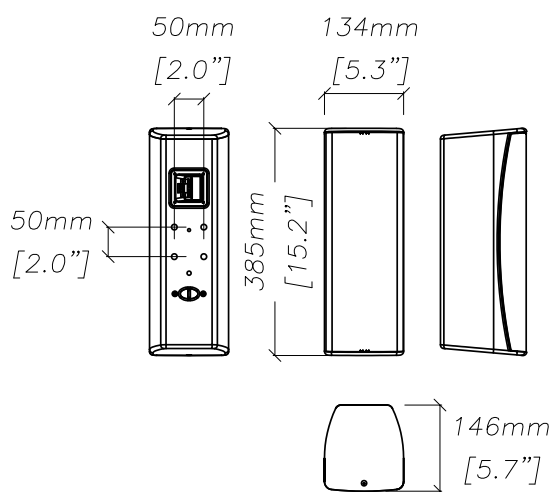

SPECIFICATIONS

Frequency Response (-10dB)	85 - 20000 Hz
Max SPL ¹	123 dB
Sensitivity (1W/1m)	91 dB
LF driver	2x 4", 1" VC
HF driver	1" carbon fiber diaphragm, 1" VC, ND magnet
Nominal coverage angle	100° x 70°, rotatable horn
Impedance	8 Ohm
Nominal power ²	100 W
Connectors	Phoenix
Dimensions (W×H×D)	385 x 134 x 146 mm 15,16" x 5,28" x 5,75"
Weight net / shipping	4,4 kg / 5,2 kg 9,7 lbs / 11,5 lbs
Mounting	VESA 50 x 50 Safety mounting point
Weather protection	IP54 rated
Enclosure material	Polycomp®, wear-resistant paint
Speaker protection	Steel grill, acoustically transparent backing

¹ - pink noise, filtered according to AES 2 - 2012, crest factor 12 dB
² - based on transducer power measured according to AES 2 - 2012

SAFETY INSTRUCTIONS

1. Do not pour liquids on the speaker system - this may cause driver cone destruction and an unappealing speaker appearance. Do not allow direct sunlight on the speaker cone in order to prevent premature failure. Do not install a speaker system near open flames or heating elements.
2. Do not use a speaker system with damaged connectors or speaker cables so as not to cause an electric shock hazard or fire hazard.
3. Make sure the speaker system is firmly set up on the floor, stage, or wall (where applicable).
4. While setting the speaker system up on an angled or slippery surface, make the necessary arrangements to avoid vibration-induced movement.
5. Speaker system is capable of delivering significant sound pressure levels. To avoid permanent or temporary hearing damage, prolonged exposure to sound pressure levels exceeding 90 dB should be limited.

ACCESSORIES



AIR-WS
Wall mounting
for AIR-C24

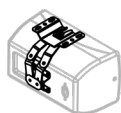

AIR-CS
Ceiling mounting
for AIR-C24

CONNECTIONS

Always use a high-pass filter (HPF) to prevent speaker damage and distorted sound by eliminating low non-audible frequencies in the input signal.

Do not exceed input power ratings mentioned in specifications while exploiting the speaker system.

The speaker system comes with a Phoenix terminal for easy connection.

Signal +	+ terminal
Signal -	- terminal
HPF frequency, no less than	95 Hz
HPF order, no less than	18 dB/oct
Recommended amplifier power	100 - 200 W on nominal impedance

