

ES EN DE

CE



DEKRA
CERTIFICATION
BGV C1



TL-054 /

TL-056

TORRE ELEVADORA

TOWERLIFT

TRAVERSENLIFT



MANUAL DE INSTRUCCIONES
OPERATING INSTRUCTIONS USER MANUAL
BEDIENUNGSANLEITUNG

PROLIFTS S.L.

V.08.19

LIFTING TOWER	TL-054 / TL-056
TORRE ELEVADORA	TL-054 / TL-056
TRAVERSENLIFT	TL-054 / TL-056



CONTENTS / ÍNDICE

Features of the TL-054/56 towerlift / Características TL-054/56.....	3 - 4
English Quick operation guide.....	5 - 11
Manual de usuario Español.....	12 - 18
Bedienungsanleitung Deutsch.....	19 - 25
Sketches / Planos piezas.....	26 - 33
Spare part list / Lista de repuestos.....	34 - 36
Certifications / Certificaciones.....	37 - 38

BGV-C1 BGG-912

EC Conformity Declaration Directive 2006/42/EC of the European Parliament and the Council of 17 May 2006 on machinery, and amending Directive 95/16/EC

Find a copy of the BGV-C1 certifications at the end of this booklet.
Puede ver una copia de las certificaciones BGV-C1 al final del manual.

MADE IN SPAIN (EU)

Manufacturer - Fabricante



PRO LIFTS S.L.
C/ Ciudad de Barcelona N°19
Pol.Ind. Fuente del Jarro
46988 Paterna (Valencia)
Tlf Export: +34 96 171 81 86
Tlf Nacional: 96 171 81 83
info@prolifts.es - www.prolifts.es

Este manual de usuario y catálogo anexo de piezas de repuesto es propiedad de PRO LIFTS S.L.
Queda prohibida su reproducción total o parcial por cualquier medio que la tecnología actual permita.
Deposito legal y copyright 2014. Todos los derechos reservados.





TL-054 / TL-056





TL-054 / TL-056

- H:** Handle / Manivela
- L:** Spirit level
- N:** Force on hand crank / Fuerza sobre manivela
- P:** Leg / Pata
- Q:** Stabilizer / Estabilizador
- R:** Catch pawl / Gatillo bloqueo patas
- SRS:** Sequence Retainer System
- W:** Winch / Cabrestante

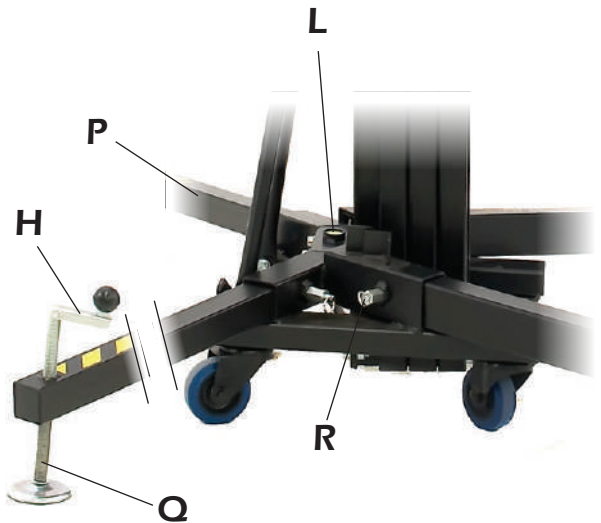
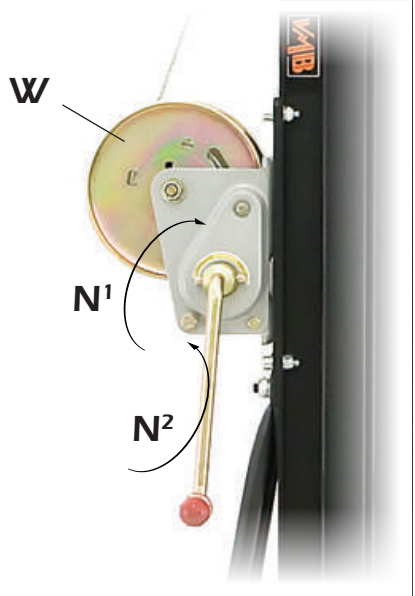

CONTENTS

1. Introduction.
2. Technical information.
3. Safety precautions.
4. Operation.
5. Maintenance.
6. Guarantee.

1. INTRODUCTION

Dear customer, in order to ensure a safe and reliable operation of the TL-054 / TL-056 towerlift please follow the instructions in this booklet carefully. Before operating the lift, read the instructions completely and please note the technical information contained within this manual.

All VMB products undergo very rigorous testing, under strict conditions and they are monitored continuously during the manufacturing process.

In order to guarantee the lifts function and safety, only original parts from the manufacturer must be used. If any parts other than those of the manufacturer are used, or the product is modified in any way, the user forfeits all warranty rights to claim. VMB reserves the right to modify the product specifications without prior notice.

The model type, production year and serial number must be quoted in any queries or orders for spare parts.

2. TECHNICAL INFORMATION

2.1 - TL-054 / TL-056 Towerlift.

2.2 - Designed to lift loads, such as trussing and lighting systems, vertically, up to different heights.

2.3 - Maximum load :
TL-054: 220 kg (485 lb).
TL-056: 200 kg (441 lb).

2.4 - Minimum load: 25 Kg (55 lb).

2.5 - Security : **ILS** (Inertial Lock Security).

2.6 - Maximum height :
TL-054: 5.45 m (17.8').
TL-056: 6.5 m (21.3').

2.7 - Folded height :
TL-054: 1.70 m (5.6').
TL-056: 1.98 m (6.5')

2.8 - Transport surface:
TL-054: 0,49x0,49x1,70m (1.6x1.6x5.6')
TL-056: 0,49x0,49x1,98m (1.6x1.6x6.5')

2.9 - Shipping dimension:
TL-054: 0,51x0,51x1,72m (1.67x1.67x5,64')
TL-056: 0,51x0,51x2,00m (1.67x1.67x6,56')

2.10 - Work surface :
2 x 2 m (6.6' x 6.6').

2.11 - Unit weight :
TL-054: 87 Kg (191 lb).
TL-056: 94.5 kg (208 lb).

2.12. - Load support:
Short forks (54.5 cm).

2.13 - Construction material : 6082-T6 aluminium for the main body, comprised of 4 profiles and a lifting carriage. Base and legs are made of steel profile according to DIN 2394. Catches and pulleys of ST-37 steel.

2.14 - Winch: 900 Kg Maximum load with automatic brake.

Certification CE and GS TÜV.

2.15 - Cable : Steel DIN 3060. Quality 180 Kg/mm² twist resistant. Cable diameter: Ø5 mm

2.16 - Adjustable stabilizing feet with rubber non-slip supports.

2.17 - Safety catches to anchor the legs.

2.18 - Antirust protection, primed paint with cured polyester dust cover. The tower can be supplied with natural aluminium finish or black (version B).

2.19 - Spirit level to adjust the tower vertically.

2.20 - Swivel wheels to transport the lift when folded.

3. SAFETY PRECAUTIONS.



3.1 - The TL-054 / TL-056 is a machine designed to elevate loads upwards in a vertical direction, It should NEVER be used as a platform to elevate people.



3.2 - Only place the lift on hard, flat surfaces always checking that it is in a vertical position by using the bubble level indicator (**L**) found on the base. Adjust the leg stabilizers (**Q**) by turning the handles (**H**) to level if necessary. NEVER use wedges or other foreign objects to balance the lift.

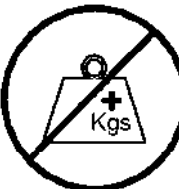

3.3 - The maximum load indicated on the characteristics label and the instructions manual should not be exceeded.



3.4 - This lift should NEVER be used to elevate a load that has not been properly checked. It is necessary to verify that the load is correctly supported and centred on the appropriate lift support so that the weight of the load will only elevate in a vertical direction.



3.5 - Check that the legs (**P**) are placed and set-up correctly with their safety pins (**R**) inserted and locked.



3.6 - NEVER use the lift on a vehicle or any other mobile surface.



3.7 - If there is a possibility of strong winds or gusts, place the lift on the ground firmly and secure it with the use of straps. NEVER attach a strap to a vehicle or any other object that can possibly be moved.



3.8 - NEVER move the lift whilst it is carrying a load. It is not advisable to carry out any type of horizontal movement even small positional adjustments.



3.9 - NEVER allow any team member below the load or anybody else in the lift's operating zone.

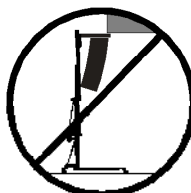

3.10 - Take care with all obstacles above the lift and its extension zone such as cornices, balconies, and luminous signboards. It is very important to avoid the presence of all types of cables below the extended lift.



3.11 - Do not use stepladders on the lift or use it as a support for them.

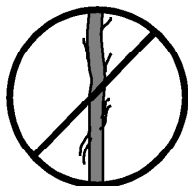

3.12 - Before using the lift, check the condition of the cable. The cable should not have broken threads or show any signs of crushed/flattened areas. NEVER use faulty cables, always change them if there is any doubt. Only use VMB steel cables; reference: DIN 3060. Quality: 180KG/mm and torsion resistant.



3.13 - All sections must be lowered first, and the legs placed in its transport position, before transportation.



3.14 - Do not grease or lubricate the winch's braking mechanism. The brake disks have been greased with a special heat and pressure resistant solution. Other products should not be used to avoid negative effects regarding the braking mechanism.

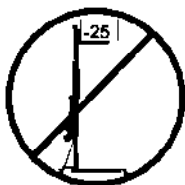

3.15 - The minimum load to avoid problems regarding the braking mechanism is 25Kg. Without this load the brake will not work.

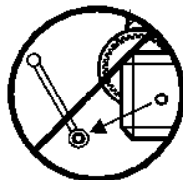

3.16 - NEVER take apart the crank of the winch when the lift is carrying a load or extended.



ORIGINAL

3.17 - Only original replacement parts should be used.

4. USER INSTRUCTIONS.

4.1 - Place the lift on a firm, flat surface in the area it is to be used with the help of the transport wheels (T).

4.2 - Remove the legs (P) from their transport compartment (S) and fully insert them into their working positions (V) checking that they are fixed by the pins (R).

4.3 - Check that the lift is in vertical position using the spirit level (L) at the base of the tower, adjust the stabilizer (Q), turning the handle (H) if necessary.

4.4 - Release the forks (F) and place them in its working position ready to take the load on them. Insert the pins to block the forks.

4.5 - DO NOT OVERLOAD THE LIFT.

TL-054 MAXIMUM LOAD IS 220 kg

TL-056 MAXIMUM LOAD IS 200 kg

The lift should NEVER be overloaded. Safety at work is the most important issue. Place the load onto the lift using an

adequate VMB support according to the need, use so that the weight of the load will only be elevated in a vertical direction. The minimum load is 25 Kg.

4.6 - How to place the load: Always load as close to the tower as possible.

The maximum load diminishes according to the distance from the body of the tower as illustrated in the diagram 4.6.1, which shows the load on the gravity centre with distances to the lifting carriage at a maximum lifting.

CAUTION

When two towers are used to elevate a truss bridge, or many towers to elevate a structure of any type, it is almost impossible that two or more people co-ordinate the winches elevating or lowering the loads, at exactly the same pace. At a certain point each tower will be extended to different height. For this reason it is necessary that the structure does not stretch and allows for these differences.

With a rigid fixation and if the level difference is significant, the force generated

Diagram 4.6.1

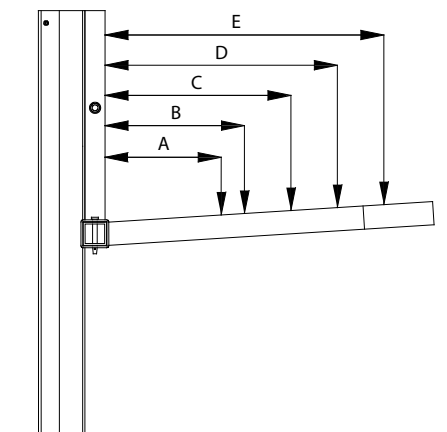

This VMB system automatically blocks each profile and the lifting carriage in the unlikely event of cable breaking.

4.7 - Elevation:

Turn the winch crank clockwise (**N¹**) to lift the carriage. The unique SRS system (Sequence Retainer System) will ensure that the profiles rise in sequence, one after the other.

4.8 - Hold:

The tower can be left in any intermediate position if it is necessary. Just stop turning the handle of the winch and leave it. The automatic brake of the winch will block it and hold the load.

4.9 - Lowering:

To bring the lift down you need to first turn the winch handle gently clockwise (**N¹**) to release the clutch of the winch. Then turn the handle anti clockwise (**N²**) until all profiles have been completely lowered.

4.10 - Transport:

For the transport of the tower is necessary to fold the machine lowering every profile completely. Once the towerlift is completely folded, place the legs in their transport compartment (**S**) and the lift will be ready to be transported.

	Distance from the load's center to the lifting carriage	Maximum load	
		TL-054	TL-056
A	25 cm (0.82')	220 kg (485 lb)	200 kg (441 lb)
B	30 cm (0.98')	198 kg (437 lb)	173 kg (381 lb)
C	40 cm (1.31')	165 kg (364 lb)	130 kg (287 lb)
D	50 cm (1.64')	141 kg (311 lb)	104 kg (229 lb)
For large forks:			
E	60 cm (1.97')	123 kg (271 lb)	86 kg (190 lb)

from the handle of the winch will deform the structure and apply a lateral force to the lifts causing them to break and block.

Security system ILS

The TL-054 / TL-056 incorporates the ILS security system (Inertial Lock Security).

5. MAINTENANCE.

5.1 - Regularly check the state of the cable. If the cable has broken threads, or if it shows any signs of crushed/flattened areas, it should be changed and replaced immediately with a new one. Do not use the lift if the cables are in bad condition. Only use VMB steel cables reference: DIN 3060 torsion resistant.

5.2 - The lift is supplied from the factory completely greased. However, it is recommended to periodically grease according to use, the gearing, the axis bearings, the spiral of the crank, and the sections.

5.3 - All lifts should undergo an annual technical inspection carried out by an authorized VMB dealer to check the certifications and general condition of all the lift's elements and security systems involved in the lift's use.

5.4 - Only use original spare parts to guarantee a continued security level. The user loses all rights to warranty if any spare parts other than originals are used or carries out any modification or alteration to the towerlift.

5.5 - To request a spare part please indicate the corresponding code which can

be found in this manual together with the lift's serial number and year of manufacture.

6. GUARANTEE.

The warranty period for this lift is 2 years from the date of purchase.

PRO LIFTS S.L. promises, that from the date of purchase and during the warranty period to resolve any faults that may occur, produced through defect material or fabrication. Damage caused by improper use, product modification, third party manipulation or accidental fire are not covered by this warranty.

7. CERTIFICATE

BGV-C1

BGG-912

EC Conformity Declaration pursuant to the EC Machinery Directives 89/392/CE and 98/37/CE: Manual lifters



INHALTSVERZEICHNIS

1. Einführung.
2. Technische Daten.
3. Sicherheitsmaßnahmen.
4. Bedienungsanleitung.
5. Wartung.
6. Garantie.
7. Zertifikat.

1. EINFÜHRUNG

Sehr geehrte Damen und Herren,
die vorliegende Betriebsanleitung wurde mit dem Zweck erstellt, eine zuverlässige Bedienung des TL-054 / TL-056 Hebeturms zu ermöglichen. Lesen Sie bitte die Betriebsanleitung vor der Inbetriebnahme sorgfältig durch. Bitte beachten Sie auch die technische Daten.

Unsere Produkte unterliegen strengsten Prüfungen und Kontrollen bei der Fertigung. Es sind ausschließlich Original-Ersatzteile zu verwenden. Für den Anwender werden alle Gewährleistungsansprüche aufgehoben, wenn er Nicht-Original-Ersatzteile verwendet bzw. Änderungen am Produkt selbst vornimmt.

2. TECHNISCHE DATEN.

2.1 - Hebeturm, Typ TL-054 / TL-056.

2.2 - Das Gerät ist zum senkrechten Heben von Lasten, wie Beleuchtungskörper auf verschiedene Höhen, konzipiert worden.

2.3 - Zulässige Hubkraft:

TL-054: 220 kg (485 lb)

TL-056: 200 kg (441 lb)

2.4 - Mindesthublast : 25 Kg.

2.5 - Zulässige Hubhöhe:

TL-054: 5.45 m (17.8')

TL-056: 6.5 m (21.3')

2.6 - Mindesthöhe:

TL-054: 1.70 m (5.6')

TL-056: 1.98 m (6.5')

2.7 - Gefaltete Dimensionen:

TL-054: 0,49x0,49x1,70m (1.6x1.6x5.6')

TL-056: 0,49x0,49x1,98m (1.6x1.6x6.5')

2.8 - Abmessungen Box:

TL-054: 0,51x0,51x1,72m (1.67x1.67x5.64')

TL-056: 0,51x0,51x2,00m (1.67x1.67x6.56')

2.9 - Grundplattenfläche :

2 x 2 m (6.6'x6.6').

2.10 - Transportgewicht:

TL-054: 87 kg (191 lb)

TL-056: 94.5 kg (208 lb)

2.11 - Werkstoffe: Aluminium 6082-T6 Profil.

Basisplatte und Ausleger aus Stahlprofil DIN 2349. Verschlüsse aus ST-37 Stahl.

2.12 - Exklusive ALS System

(Pat. Pen. 200501056)

2.13 - Die Winde: 900/1000 kg.

2.14 - Seildurchmesser: Steel DIN 3060.

Qualität 180 kg/ mm 2.

Durchmesser: Ø5 mm

2.15 - Ausleger mit verstellbaren Spindeln und rutschfesten Gummifüßen.

2.16 - Verankerung der Ausleger über Sicherheitsrastbolzen.

2.17 - Wasserwaage zum Einstellen der senkrechten Turmlage.

2.18 - Korrosionsschutz und Veredelung durch elektrolytische Cadmierung oder

(Version B) Satinpolyester. Erhältlich in Natur Aluminium oder.

2.19 - Transportrollen zum Bewegen des Turms bei senkrechter und eingefahrener Stellung zur Arbeitsstelle.

(optional TL-054/056)

3. SICHERHEITSMABNAHMEN.



3.1 - Der TL-054 / TL-056 wurde konzipiert zum Heben und Senken von vertikalen Lasten. Nutzen Sie ihn niemals zur Beförderung von Personen.



3.2 - Achten Sie darauf, dass der TL-054 / TL-056 Tower auf festem, geradem Untergrund steht. Und vergewissern Sie sich mit Hilfe der Wasserwaage (F), dass er eine vertikale Position zum Boden eingenommen hat. Bei Bedarf mittels des Stellellers (Q) durch Drehen der Spindelkurbel (H) die entsprechende Tunlage einstellen.



3.3 - Die zulässige Höchstlast, die Sie auf den Typenschild, welche sie in der Bedienungsanleitung finden, darf niemals überschritten werden

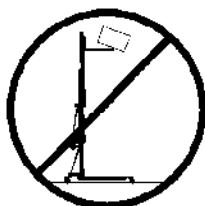

3.4 - Niemals sollten Sie eine ungesicherte Ladung heben. Vergewissern Sie sich immer, dass die Ladung zentriert auf der Gabel aufliegt und nur in vertikaler Richtung hebt!



3.5 - Vergewissern Sie sich, dass die Ausleger richtig eingesteckt sind und nutzen Sie die Rastbolzen zum feststellen!



3.6 - Es ist nicht gestattet den Lift auf einem Fahrzeug mit einen mobilen Unterbau zu installieren!

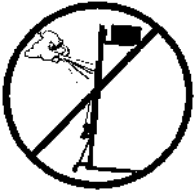

3.7 - Bei Freiluftanwendungen den Turm auf festen Boden stellen und mittels Seilanker gegen Windbelastung sichern. Niemals an Fahrzeugen die Abspannungen befestigen oder an Gegenständen, die ausweichen könnten.



3.8 - Bewegen Sie den Lift niemals unter Belastung.



3.9 - Halten Sie sich niemals während des Hebens und Senkens in Gefahrenbereich auf.

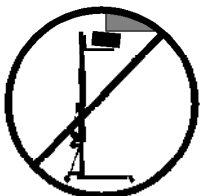

3.10 - Achten Sie auf alle Gegenstände im oberen Hubbereich des Liftes. Achten Sie auf Balkone, Leuchtschriften und besonders auf stromführende Kabel.



3.11 - Stellen Sie niemals Leitern an den Tower.

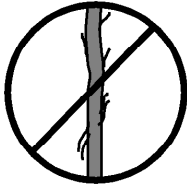

3.12 - Vor Gebrauch Seilzustand kontrollieren. Das Seil darf keine Seilbrüche oder Quetschungen aufweisen. Es dürfen auf keinem Fall Seile in einem schlechten Zustand verwendet werden.



3.13 - Alle Angebauten Teile sind für den Transport einzufahren.



3.14- Ölen oder Fetten der Fallbremsen ist zu unterlassen, da diese mit einem Druck und Hitzebeständigen Material bearbeitet wurden. Andere Werkstoffe führen in der Handhabung zu negativen Effekten.

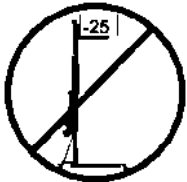

3.15 - Die maximale Belastung zur Überprüfung der Sicherungen ist 50 kg. Ohne Belastung ist die Überprüfung nicht möglich.

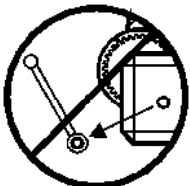

3.16 - Niemals die Winde, oder Teile der Winde unter Belastung demontieren.



ORIGINAL

3.17 - Es sind ausschließlich Original Ersatzteile zu verwenden. Für den Anwender werden alle Gewährleistungsansprüche aufgehoben, wenn nicht Original Ersatzteile verwendet bzw. Änderungen an Produkten vorgenommen werden.

4. Bedienungsanleitung.

4.1 - Den Hebeturm auf den Transportrollen (**T**) abgestützt auf eine ebene und feste Fläche an der Arbeitsstelle aufstellen.

4.2 - Die Ausleger (**P**) aus der Transporhalterung (**S**) herausnehmen und in deren Arbeitsaufnahmen (**V**) voll einschieben. Dabei achten Sie bitte darauf, daß sie mittels der Sicherheitsbolzen (**R**) befestigt sind.

4.3 - Die senkrechte Turmlage über die verstellbaren Stellteller (**Q**) durch Drehen der Kurbel (**H**) in entsprechender Richtung zum Zentrieren der Wasserwaagenblase (**F**) an der Kreismitte einstellen.

4.4 - Die Sicherheitsbolzen (**L**) der Lastaufnahmeausleger entfernen, die Ausleger zur Lastaufnahme (**U**) in einer waagerechten Position bringen und die Sicherheitsbolzen wieder anbringen.

4.5 - Die zu hebende Last auf dem Turm mittels eines geeigneten Trägers so aufstellen, dass das Lastgewicht nur senkrecht wirkt. Die maximale Last von 240 kg darf nie überschritten werden.

Diagram 4.6.1

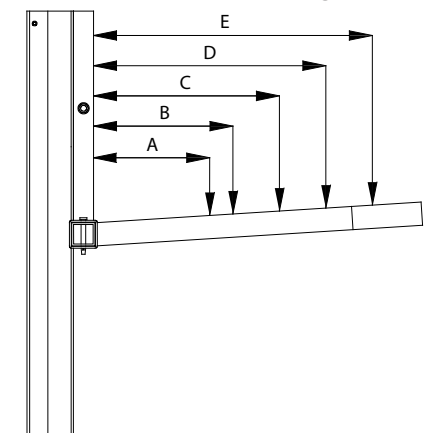

	Distance from the load's center to the lifting carriage	Maximum load	
		TL-054	TL-056
A	25 cm (0.82')	220 kg (485 lb)	200 kg (441 lb)
B	30 cm (0.98')	198 kg (437 lb)	173 kg (381 lb)
C	40 cm (1.31')	165 kg (364 lb)	130 kg (287 lb)
D	50 cm (1.64')	141 kg (311 lb)	104 kg (229 lb)
For large forks:			
E	60 cm (1.97')	123 kg (271 lb)	86 kg (190 lb)

4.6 - Plazieren der Ladung:

Plazieren Sie die Ladung so nah wie möglich in Richtung des Towers. Die Maximalbelastung reduziert sich, gemäß dem nebenstehenden Diagramm.

Achtung!

Werden zwei Stative dazu benutzt, eine Traverse oder mehrere Stative dazu benutzt, eine Konstruktion jedweden Typs anzuheben, ist es fast unmöglich, dass zwei oder mehrere Bediener in der Lage sind, die Winde in der exakt gleichen Geschwindigkeit zu bedienen, um die Last anzuheben oder abzusenken.

Ab einem bestimmten Punkt wird sich jeder Tower in einer anderen Höhe als der andere befinden.

Aus diesem Grund ist es notwendig, dass die Konstruktion in der Lage ist, diese Differenz auszuhalten. Bei einer starren Fixierung und wenn der Höhenunterschied sehr groß ist, wird die Kraft, die von der Winde erzeugt wird, die Konstruktion deformieren und dazu führen, dass die Lifte, ausgelöst durch seitlich wirkende Kräfte, brechen oder blockieren.

Die Tower können in jeder notwendigen Zwischenposition belassen werden. Beenden Sie einfach das Drehen der Winde. Die automatische Bremse wird die Position der Last halten.

4.7 - Heben:

Die Transportsicherung (**O**) entriegeln. Den Lift mittels Drehen der Winde (**W**) in Uhrzeigersinn (**N1**) in die gewünschte Höhe kurbeln.

4.8 - Halten:

Die Last kann in jeder Position erhalten werden. Stoppen Sie dazu lediglich das Drehen der Kurbel. Die Automatic in der Winde und die Fallbremse sichern die Ladung. Für den Transport des Turmes ist dieser durch Senken der Einzelabschnitte herunterzufahren. Es ist sehr wichtig den Schlitten in seiner Parkposition wieder zu verriegeln (**B**). Die Ausleger entsperren und diese in ihre Transportstellung (**S**) bringen. Die Befestigungsschraube anziehen.

4.9 - Senken:

Zum Transport die Sicherung (**O**) wieder einrasten die Handkurbel der Winde gegen den Uhrzeigersinn drehen, bis der Lift in einer Endposition ist. Der Lift kann in jeder beiliegenden Zwischenstellung angehalten werden. Durch kurzes anheben der Ladung mittels der Winde lässt sich ALS - Lock entriegeln (rot). Drücken Sie diese und lassen Sie die Last mittels Winde ab. Sollte der ALS – Lock blockieren heben Sie die Last erneut an und wiederholen Sie den Vorgang.

5. Wartung.

5.1 - Regelmäßig den Seilzustand kontrollieren. Weist ein Seil Drahtbrüche bzw. Quetschungen auf, ist es sofort durch ein neues zu ersetzen. Unter keinen Umständen den Hebeturm mit Seilen in schlechtem Zustand verwenden.

Nur verwindungssteifes Stahlseil nach DIN 3060 verwenden.

5.2 - Der Hebeturm wird werkseitig komplett geschmiert geliefert. Es wird jedoch empfohlen, regelmäßig (je nach Bedarf) das Zahnrad des Winde, die Wälzlager der Antriebswelle und Hülse, das Kurbelgewinde und die Abschnitte zu schmieren.

Achtung: Die Bremsscheiben nicht einölen oder fetten !!!

5.3 - Der Hebeturm TL-054/56 sollte von einer Fachkraft mindestens einmal jährlich geprüft werden.

5.4 - Für eine kontinuierliche Betriebssicherheit sind ausschließlich Original – Ersatzteile zu verwenden. Alle Gewährleistungsansprüche sind für den Anwender aufgehoben, wenn er Nicht- Original – Ersatzteile verwendet bzw. Änderungen am Produkt selbst vornimmt.

5.5 - Für die Bestellung von Ersatzteilen ist

stets dessen Bestellnummer anzugeben, welche den Stücklisten-Blättern dieser Anleitung zu entnehmen ist.

VMB Service Deutschland:

Tel : 04442 - 92900

Fax: 04442 - 929090

6. Garantie.

Ab Kaufdatum und innerhalb der Garantiezeit beim Händler beseitigt die PRO LIFTS S.L. alle material-order herstellungsbedingten Mängel durch Reparatur oder Austausch.

In Europa gilt eine Garantiezeit von mindestens 24 Monaten.

Von der garantie ausgenommen sind Schäden aufgrund von unsachgemäßen Gebrauch, Verschleiß oder Eingriffen Dritter. Die Garantie umfasst keine Verbrauchsmaterialien und Mängel, die den Wert oder die Gebrauchstauglichkeit nur unerheblich beeinträchtigen.

7. Zertifikat

BGV-C1

BGG-912

EC Conformity Declaration pursuant to the EC Machinery Directives 89/392/CE and 98/37/CE: Manual lifters



TL-054 & TL-056 SPARE PARTS SKETCHES /
CROQUIS DE LAS PIEZAS DE REPUESTO DE TL-054 y TL-056

A	Profiles / Barras.....	28
	TL-054 Profiles / Barras TL-054	
	TL-056 Profiles / Barras TL-056	
A.1	SRS System / Sistema retentor SRS	
A.2	Cable fixation / Prisionero cable	
A.3	Base profile lower area / Zona inferior perfil Base	
A.4	Profile upper area / Zona superior barras	
A.5	Alluminium stop piece / Pieza de aluminio tope barras	
B	Base / Base.....	30
B.1	Wheels / ruedas	
B.2	Screws for the base / Tornillería de la Base	
B.3	Reinforcing struts / Tirantes de refuerzo	
B.4	Leg locks / Gatillos patas	
B.5	Pin and “R” clip / Pasadores y clips “R”	
C	Winch / Cabrestante.....	31
	Forks / Brazos de carga	
	Fork support / Soporte brazos de carga	
D	Lifting carriage / Carro elevador.....	32
D.1	Fixation screw for fork support / Tornillo fijador soporte brazos de carga	
D.2	Nylon roller / Rodillos	
D.3	Inertial break / Freno de inercia	
D.4	Profile stop piece / Taco tope barra	
D.5	Pulley system of the carriage lower area / Sistema de rodillos y poleas inferior carro	
E	Legs / Patas.....	33
E.1	Leg transport support / Porta-patas para transporte	
E.2	Complete legs and legs profile / Patas completas, y perfiles patas	
E.3	Complete stabilizer kit and stabilizer exploded / Estabilizador completo y despiece estabilizador	



TL-054

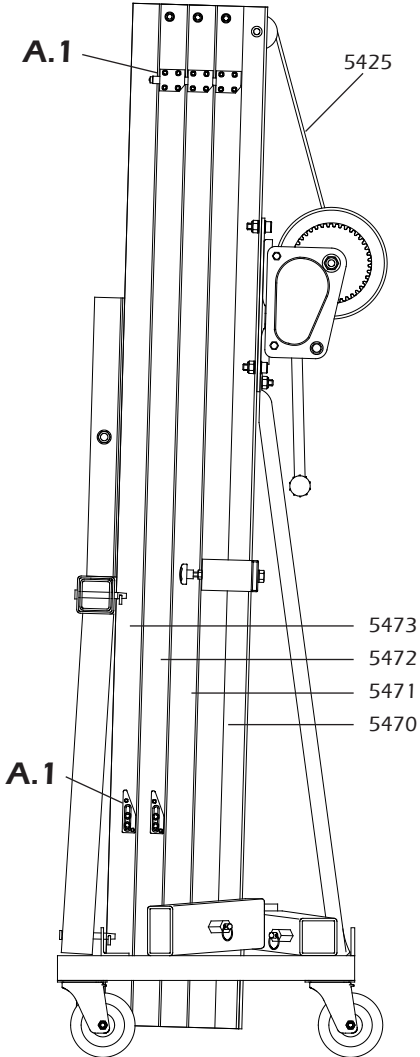

TL-056

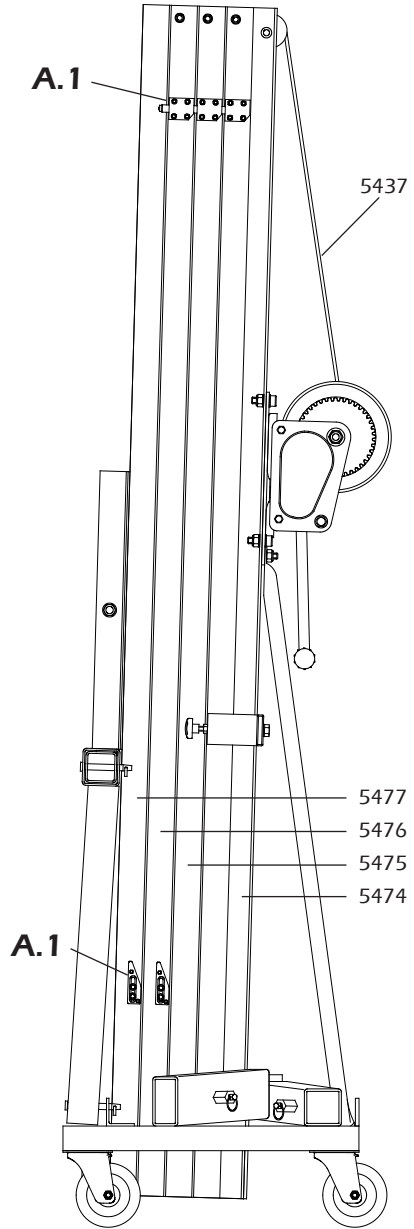

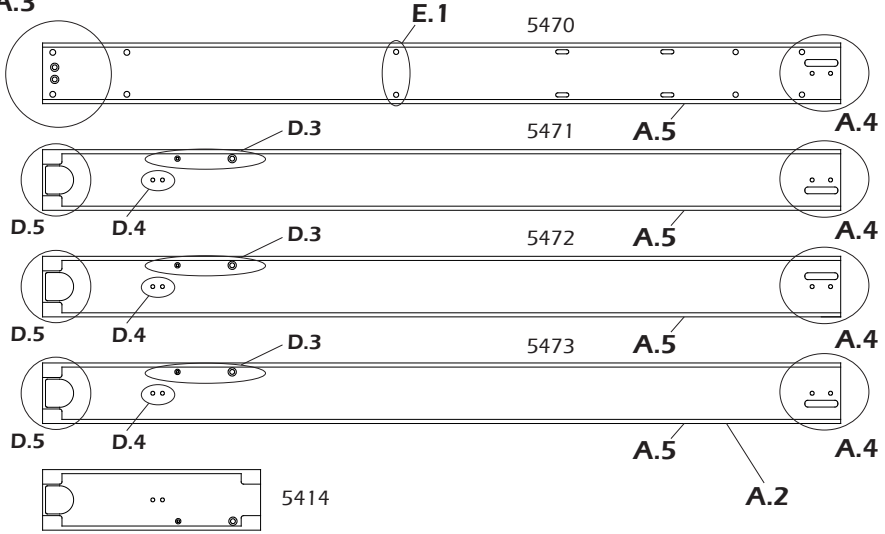
TL-054**A.3****TL-056**



A.1

Profile 5472 (TL-054)
Profile 5476 (TL-056)

Profile 5471 (TL-054)
Profile 5475 (TL-056)

Profile 5470 (TL-054)
Profile 5474 (TL-056)

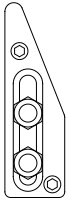

1540

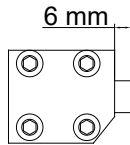

6 mm

1531

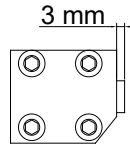

3 mm

1532

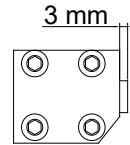

3 mm

1532

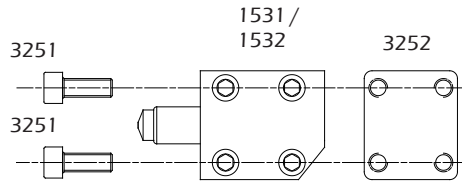
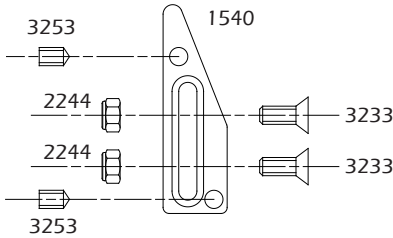

A.2

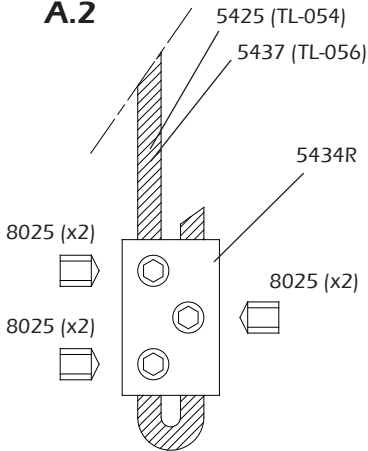

A.3

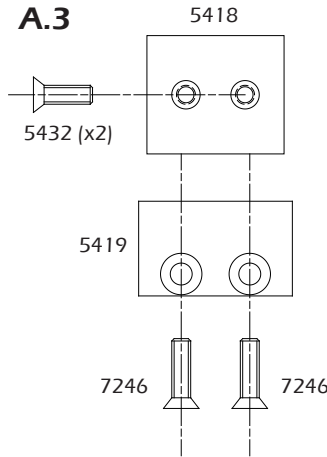

A.5

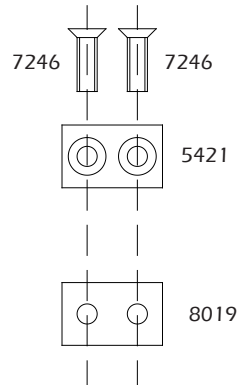

A.4

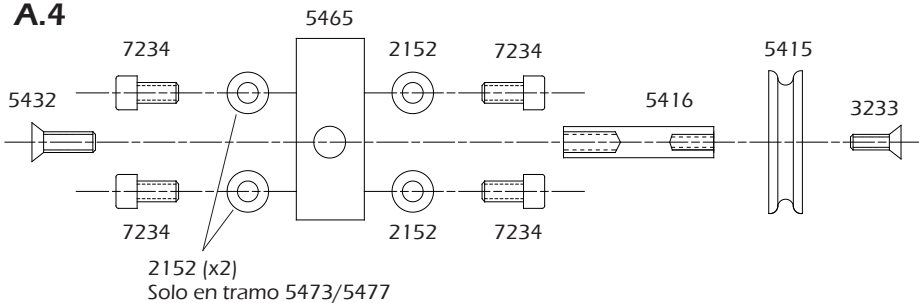



B.1

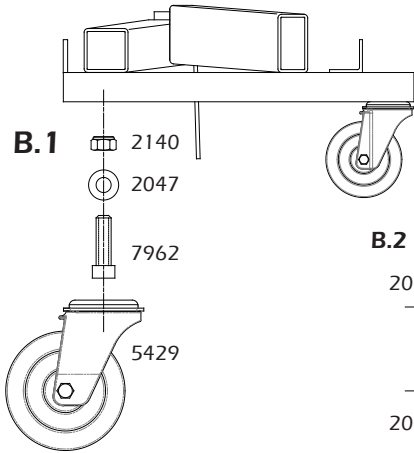

B.2

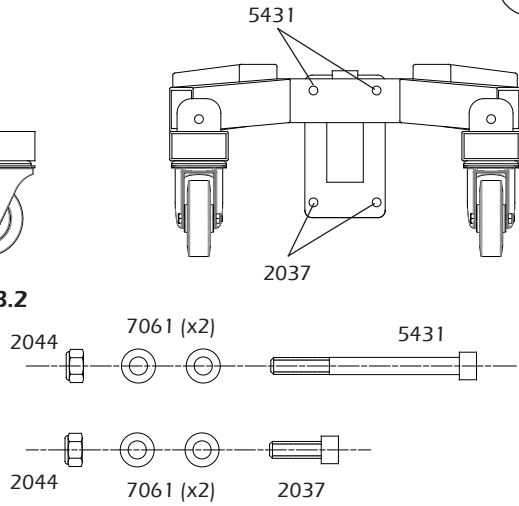

5408

6409

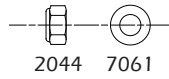

B.3

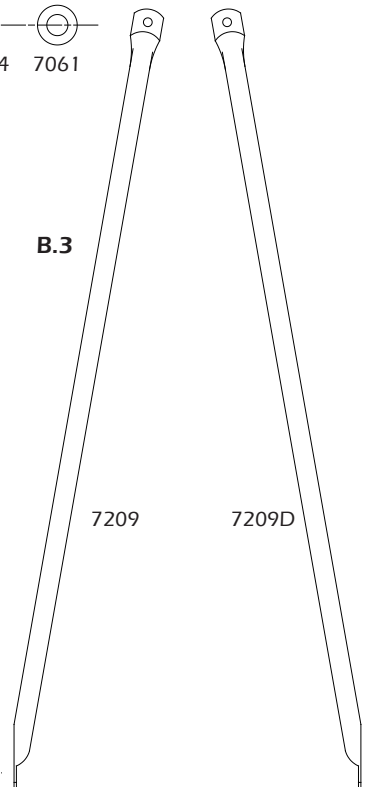

B.4

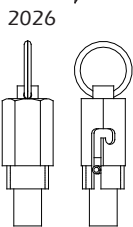

B.5

MR-PAS

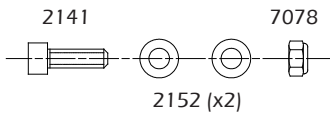
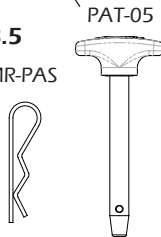

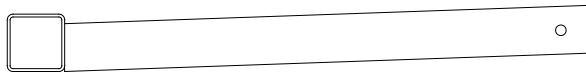
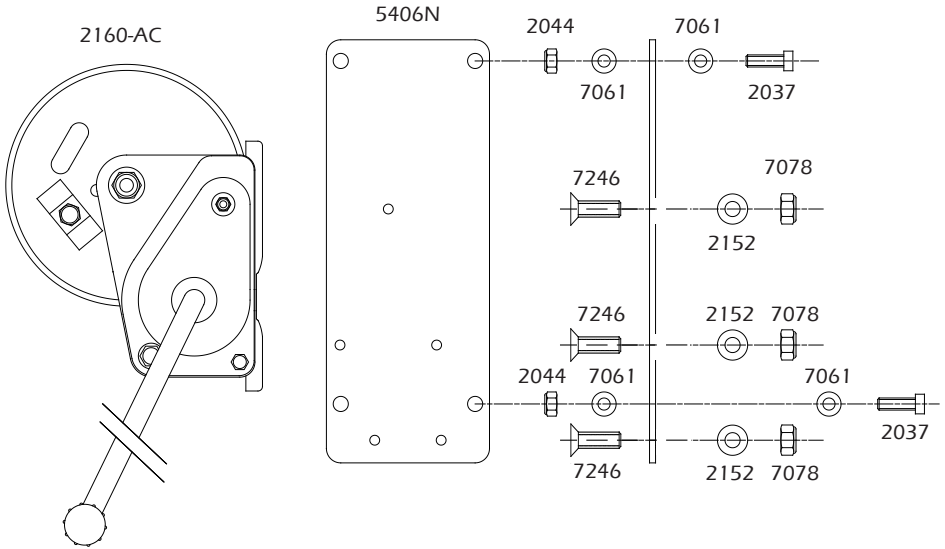

7040

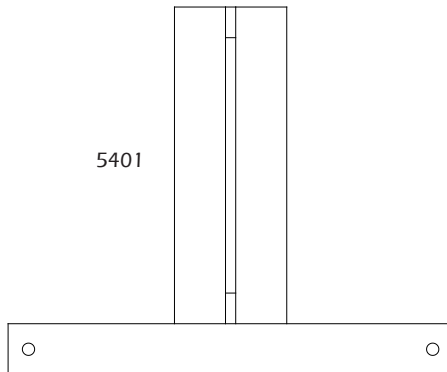
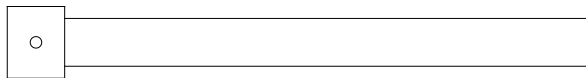

5401

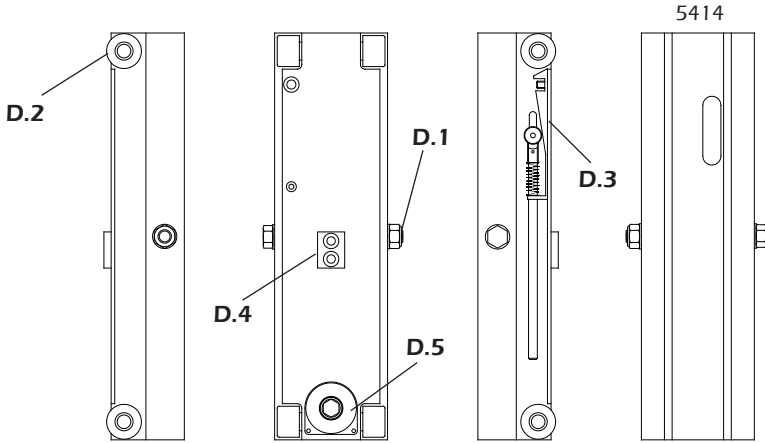

D.1

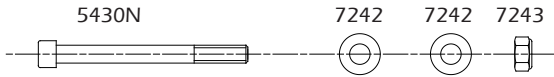

D.3

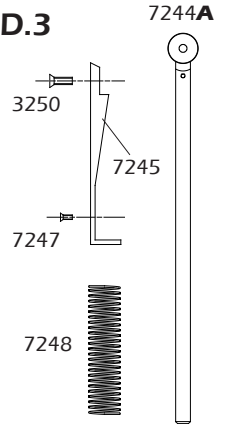

D.2

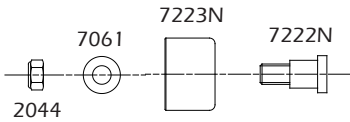

D.4

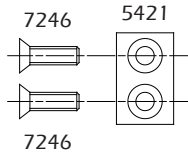

D.5

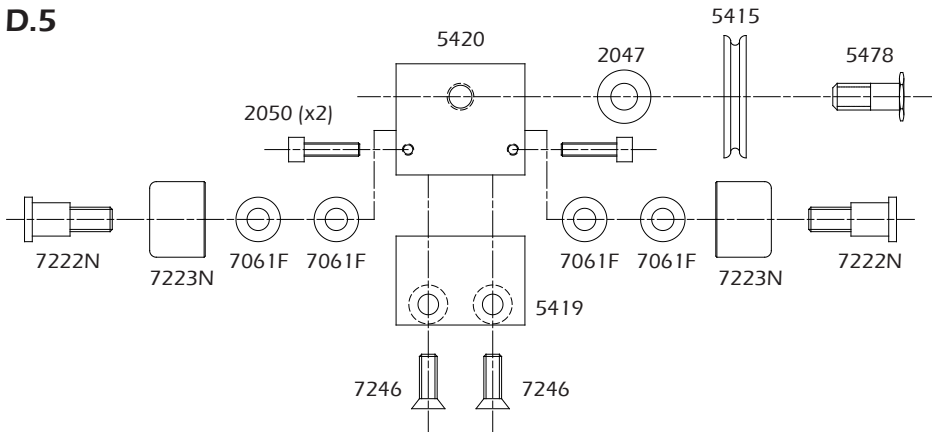

E.1

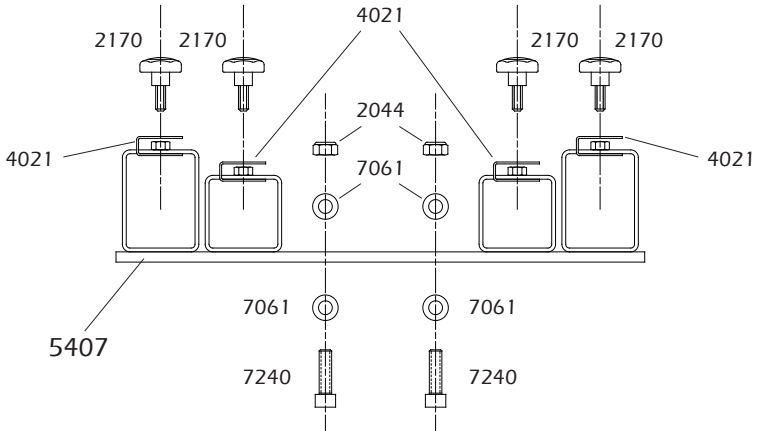

E.2

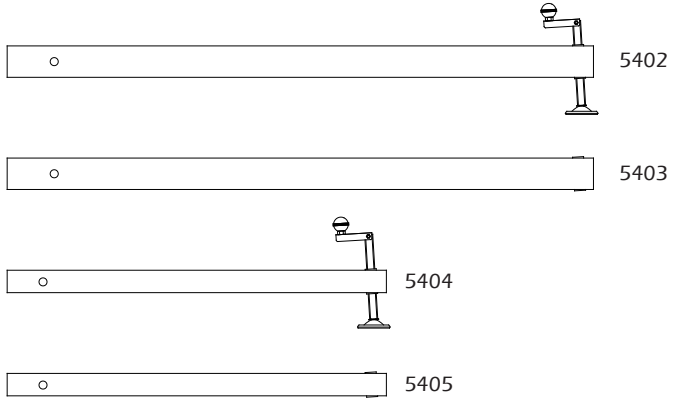

E.3

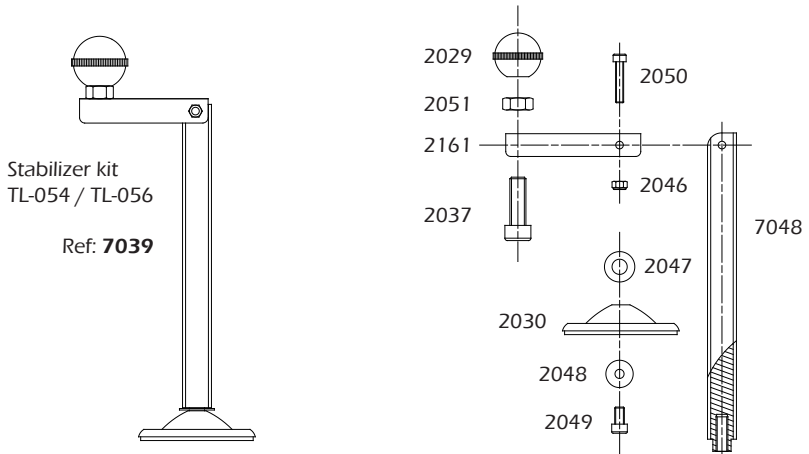

SPARE PARTS LIST / LISTA DE REPUESTOS TL-054 / TL-056

Code	Description GB / USA	Descripción ES
1531 (B)	SRS Unit Profile 3 (B black)	Pieza Retentor tramo 3 (B Negro)
1532 (B)	SRS Unit Profile 1 & 2 (B black)	Pieza Retentor tramo 1 y 2 (B Negro)
1540 (B)	SRS Unlock (B black)	Desbloqueador sistema SRS (B Negro)
2026	Safety catch	Gatillo de seguridad
2029	Crank nob Ø34	Pomo baquelita estabilizador patas Ø34
2030	Stabilizer round plate	Platillo de apoyo estabilizador patas Ø84
2037	M10x30 Allen screw	Tornillo allen M10x30
2044	M10 Auto-block nut	Tuerca autoblocante M10
2046	M5 Auto-block nut	Tuerca autoblocante M5
2047	M12 Washer	Arandela M12
2048	M6 Washer	Arandela M6
2049	M6x10 Allen screw	Tornillo allen M6x10
2050	M5x25 Allen screw	Tornillo allen M5x25
2051	M10 Nut	Tuerca M10
2140	M12 Auto-block nut	Tuerca autoblocante M12
2141	M8x25 Allen screw	Tornillo allen M8x25
2152	M8 Washer	Arandela M8
2160-AC	900kg Winch (Short crank)	Cabrestante 900kg (Short crank)
2161	Steel hand crank	Manivela estabilizador patas
2170	Screw knob	Pomo con rosca
2244	M6 Auto-block nut	Tuerca autoblocante M6
3233	Conic screw M6x16	Tornillo cabeza cónica M6x16
3250	M8x20 Conic screw	Tornillo cabeza cónica M8x20
3251	M6x16 Allen screw	Tornillo allen M6x16
3252	SRS screwed plate	Pletina roscada Retentor
3253	M6x10 Headless allen bolt	Tornillo allen sin cabeza M6x10
4021 (B)	Tightening knob protector (B Black)	Protector apriete pomos (B Negro)
5401 (B)	Fork support (B Black)	Soporte brazos de carga (B Negro)
5402 (B)	Complete long leg (B Black)	Pata larga completa (B Negro)
5403 (B)	Long leg profile (50x70x1308mm) (B Black)	Perfil pata larga (50x70x1308mm) (B Negro)
5404 (B)	Complete short leg (B Black)	Pata corta completa (B Negro)

Code	Description GB / USA	Descripción ES
5405 (B)	Short leg profile (50x50x846mm) (B Black)	Perfil pata corta (50x50x846mm) (B Negro)
5406N (B)	Winch fixation plate (B Black)	Placa portacabrestante (B Negro)
5407 (B)	TL-054 / TL-056 Legs support (B Black)	Porta-patas TL-054 / TL-056 (B Negro)
5408 (B)	TL-054 / TL-056 Base (B Black)	Base TL-054 / TL-056 (B Negro)
5414 (B)	Lifting carriage (B black)	Carro elevador (B Negro)
5415	Special pulley Ø55	Polea especial Ø55
5416	Steel axe Ø12x58	Eje de acero Ø12x58
5418	Alluminium stop holding piece	Pieza de aluminio sujeta tope
5419	Alluminium stop piece	Tope de aluminio
5420	Alluminium stop holding piece	Pieza de aluminio sujeta tope
5421	Alluminium stop piece	Tope de aluminio
5425	Steel cable Ø5mm x 14.2m	Cable de acero Ø5mm x 14.2m
5429	Wheel Ø100	Rueda Ø100
5430N	M14x150 Allen screw	Tornillo allen M14x150
5431	M10x90 Allen screw	Tornillo Allen M10x90
5432	M8x20 Conic screw	Tornillo cabeza cónica M8x20
5434R	Cable grip (6 screws)	Pieza fijación cable (6 Tornillos)
5437	Steel cable Ø5 mm x 16.7m	Cable de acero Ø5 mm x 16.7m
5465	Alluminium M12 axel support	Pieza de aluminio soporte eje M12
5470 (B)	Base profile 1 (B Black) TL-054 (1648mm)	Tramo 1 Base (B Negro) TL-054 (1648mm)
5471 (B)	Profile 2 (B Black) TL-054 (1648mm)	Tramo 2 (B Negro) TL-054 (1648mm)
5472 (B)	Profile 3 (B Black) TL-054 (1648mm)	Tramo 3 (B Negro) TL-054 (1648mm)
5473 (B)	Profile 4 (B Black) TL-054 (1648mm)	Tramo 4 (B Negro) TL-054 (1648mm)
5474 (B)	Base profile 1 (B Black) TL-056 (1930mm)	Tramo 1 Base (B Negro) TL-056 (1930mm)
5475 (B)	Profile 2 (B Black) TL-056 (1930mm)	Tramo 2 (B Negro) TL-056 (1930mm)
5476 (B)	Profile 3 (B Black) TL-056 (1930mm)	Tramo 3 (B Negro) TL-056 (1930mm)
5477 (B)	Profile 4 (B Black) TL-056 (1930mm)	Tramo 4 (B Negro) TL-056 (1930mm)
5478	Special thin head screw M12x30	Tornillo especial cabeza fina M12x30
6409	Spirit level Ø30mm	Nivel de burbuja Ø30mm
7039	Complete stabilizer	Estabilizador completo
7040 (B)	Short load support fork (B Black) (54.5cm)	Brazo de carga corto (B Negro) (54.5cm)
7048	M18 Threaded bolt	Perno roscado M18

Code	Description GB / USA	Descripción ES
7061	M10 Washer	Arandela M10
7061F	M10 Thin washer for adjustments	Arandela fina de ajuste M10
7078	M8 Auto-block nut	Tuerca autoblocante M8
7209 (B)	Left reinforcement strut (B Black)	Tirante de refuerzo izquierdo (B Negro)
7209D (B)	Right reinforcement strut (B Black)	Tirante de refuerzo derecho (B Negro)
7222N	Special screw for nylon roller	Tornillo especial para rodillo de nylon
7223N	Nylon roller	Rodillo nylon
7234	M8x16 Screw	Tornillo M8x16
7240	M10x35 Allen screw	Tornillo allen M10x35
7242	M14 Washer	Arandela M14
7243	M14 Auto-block nut	Tuerca autoblocante M14
7244A	Inertial Brake lock rod (Ø21mm disk)	Varilla freno de inercia (disco Ø21mm)
7245	Brake lock support	Soporte varilla freno de inercia
7246	M8x25 Conic screw	Tornillo cabeza cónica M8x25
7247	M5x10 Conic screw	Tornillo cabeza cónica M5x10
7248	Brake spring	Muelle freno de inercia
7962	M12x40 Allen screw	Tornillo allen M12x40
8019	Alluminium screwed piece for stop piece	Pieza fijación tope de aluminio
8025	M8x10 Headless allen bolt	Tornillo allen sin cabeza M8x10
MR-PAS	'R' Clip	Clip de seguridad 'R'
PAT-05	Magnetic steel pin Ø10x84.5mm	Pasador acero imantado Ø10 x 84.5mm

REMEMBER TO QUOTE THE TYPE, PRODUCTION YEAR AND SERIAL NUMBER OF THE TOWERLIFT.

RECUERDE CITAR EL MODELO, EL AÑO DE PRODUCCIÓN Y EL NÚMERO DE SERIE DE LA TORRE ELEVADORA.

Vergessen Sie nicht den MODELLJAHR DER PRODUKTION und Seriennummer des HEBETURM zitieren.

Test report about an acceptance inspection

Device typ: Towerlift

Typ: TL-054

Fabrikator: Prolifts S. L.
Pol. Ind. Picassent
Calle 7
E-46220 Picassent
VALENZIA

Technical specifications: charge maximum: 220 kg
tare: 87 kg
minimum high: 1,70 m
maximum high: 5,45 m
Surface base : 2 x 2m

Foundation : BGV C1, BGG 912

Test result: The accomplishment of the towerlift complies the safty-related receivables of the BGV-C1.

Clue: At each towerlift is an EG-declaration of conformity to deliver.

Bevor the towerlift is commissioning at first is an optical control from an assessor after BGG 912 necessary.

Berlin, 05.11.2007



Dipl.-Ing. Konrad Haak

Test report about an acceptance inspection

Device typ: Towerlift
Typ: TL-056
Fabrikator: Prolifts S. L.
Pol. Ind. Picassent
Calle 7
E-46220 Picassent
VALENZIA

Technical specifications: charge maximum: 200 kg
tare: 94,5 kg
minimum high: 1,98 m
maximum high: 6,50 m
Surface base : 2 x 2m

Foundation : BGV C1, BGG 912

Test result: The accomplishment of the towerlift complies the safety-related receivables of the BGV-C1.

Clue: deliver. At each towerlift is an EG-declaration of conformity to

Bevor the towerlift is commissioning at first is an optical control from an assessor after BGG 912 necessary.

Berlin, 05.11.2007



Dipl.-Ing. Konrad Haak



facebook / vmblifts



Canal VMBLifts



*For further information follow the advise of our technicians:
Para más información consulte con nuestros técnicos en:*



PRO LIFTS S.L.

C/ Ciudad de Barcelona Nº19
Pol. Ind. Fuente del Jarro
46988 Paterna (Valencia) Spain
Tlf Export: +34 96 171 81 86
Tlf Nacional: 96 171 81 83

email: info@prolifts.es web: www.prolifts.es