

The Qt[®] Active Emitter

A powerful all-in-one sound masking, office paging, and background music loudspeaker



The Qt® Active Emitter

SMALL AND POWERFUL

The new Qt® Active Emitter is a single-source Emitter capable of both sound masking and simultaneous clear reproduction of paging and music signals. It provides higher SPL and a broader frequency range than previous direct field Emitter offerings in a small, powerful speaker that's virtually invisible once deployed in finished or open structure ceilings.

UNIFORM DIRECT FIELD MASKING

Traditional sound masking systems use large loudspeakers the size of paint cans to reverberate sound off of the ceiling deck that indirectly distribute masking sound into an environment. In contrast, the small, sleek Qt Active Emitter utilizes Cambridge Sound Management's patented direct field Quiet Technology to deliver uniform sound masking directly into the workspace.

Superior sound masking uniformity and coverage in a speaker half the size of any competitive offering.

Qt® Active Emitter



3.25" Width x 3.5" Height

Great sound masking, paging, and music performance in one speaker

Competitive Speakers

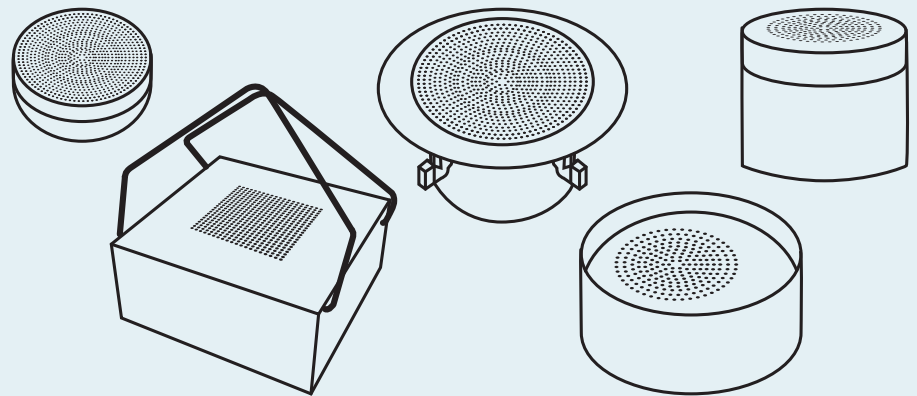

Often require separate loudspeakers for sound masking and paging

CLEAR, ARTICULATE PAGING AND BACKGROUND MUSIC

Another benefit of direct field technology is improved audio clarity for paging and music. Because pages are being emitted directly into the environment, they're clearer and easier for listeners to understand. Music sounds better too because the speaker is facing the listener instead of being played through a ceiling material. The Qt Active Emitter is the only sound masking loudspeaker that's a complete masking, paging, and music solution for office environments.

THE FAVORITE INSTALLATION CHOICE OF INTEGRATORS

The Qt Active Emitter uses the same control modules and cabling infrastructure that made QtPro™ the number one sound masking system choice of companies worldwide as well as the favorite installation choice of integrators. As a result, QtPro remains the easiest sound masking system to install and calibrate, regardless of whether the Active Emitter or original Emitter is used—a true plug and play experience with preset sound masking curves designed specifically for each emitter type.

FEATURES

- Active electronics power the speaker
- Ported enclosure design allows lower frequency extension down to 125 Hz octave band for sound masking and 115 Hz for paging and music
- 17 dB louder than previous direct field emitter offerings
- Plenum-rated, UL-listed, and complies with UL 2043
- Delivers four uncorrelated audio channels to reduce phasing/comb-filtering
- Comes standard with a slip-ring mount for acoustical tile mounting
- Rear DIP switches reduce volume by 4.5 dB in 1.5 dB increments, if needed
- Compatible with DynasoundPro Network System (Specify DS1320)

BENEFITS

- Delivers superior uniformity which leads to a more comfortable sound masking experience and clear, quality office paging and background music
- Small but powerful speaker that's virtually invisible once deployed in finished or open structure ceilings
- Utilizes the same control modules, cabling infrastructure, and speaker driver size as other Cambridge Sound Management systems, ensuring QtPro remains the easiest sound masking system to install and calibrate
- Provides new opportunities for sound masking system customization and optimization
- Features an extended sound masking spectrum for additional comfort
- Ability to use both the Qt Active Emitter and original Qt Emitter on the same control processor simultaneously, if needed (requires separate zones)

TECHNICAL SPECIFICATIONS

*Sound Masking Frequency Response:	125 Hz - 10,000 Hz
*Music / Paging Frequency Response:	115 Hz - 12,000 Hz (-10 dB)
*Masking Min - Max SPL:	30 dBA to 60 dBA @ 1 meter
*Music / Paging Max SPL:	74 dBA @ 1 meter
Nominal Impedance:	40,000 Ω
Nominal Dispersion:	170 degrees conical / half space
Connections:	Input / Output - RJ45 Modular Jack
Channel Selection:	Four Channel Auto Sequencing and Repeating
Selectable Attenuation:	0 dB, -1.5 dB, -3 dB, -4.5 dB
Cabling:	Category UTP Cabling (8 conductor)
Included Accessories:	Acoustic Ceiling Tile Mounting Ring
Loudspeaker Type:	Active w/ Integral Amplifier
Maximum Power Consumption:	2 Watts
Operating Voltage:	36 VDC
Driver Diameter:	1.25" (3.2 cm)
Enclosure:	Front Vented
Color:	White
Height:	3.5" (8.9cm)
Diameter:	3.25" (8.3cm)
Weight:	6.5 oz. (184 g)
Certifications:	UL 2043
SKU:	E-P-W-16-4 (4 Pack of White Emitters with 4 x 16ft Cables)

* Specifications based on emitter array using published layout practices in conjunction with Qt Control Processor.

REQUIRED ACCESSORIES

Power is delivered via an external power supply and power injectors, both available as accessories.



Active Emitter Power Supply

- Supplies power to Qt Active Emitters
- Capacity to power 150 Qt Active Emitters
- Three Output Connectors (50 Emitters per output)
- Utilizes 14/2 conductor cabling to power Qt Active Emitter Power Injector
- Rack or wall mountable



Active Emitter Power Injector

- Combines DC power from Qt Active Emitter Power Supply and Signal from QtPro Controller for Qt Active Emitters
- Two outputs: each supports up to 25 Qt Active Emitters
- Plenum or headend mounted – fits in standard 4x4 electrical box

QT ACTIVE EMITTER CABLING OVERVIEW

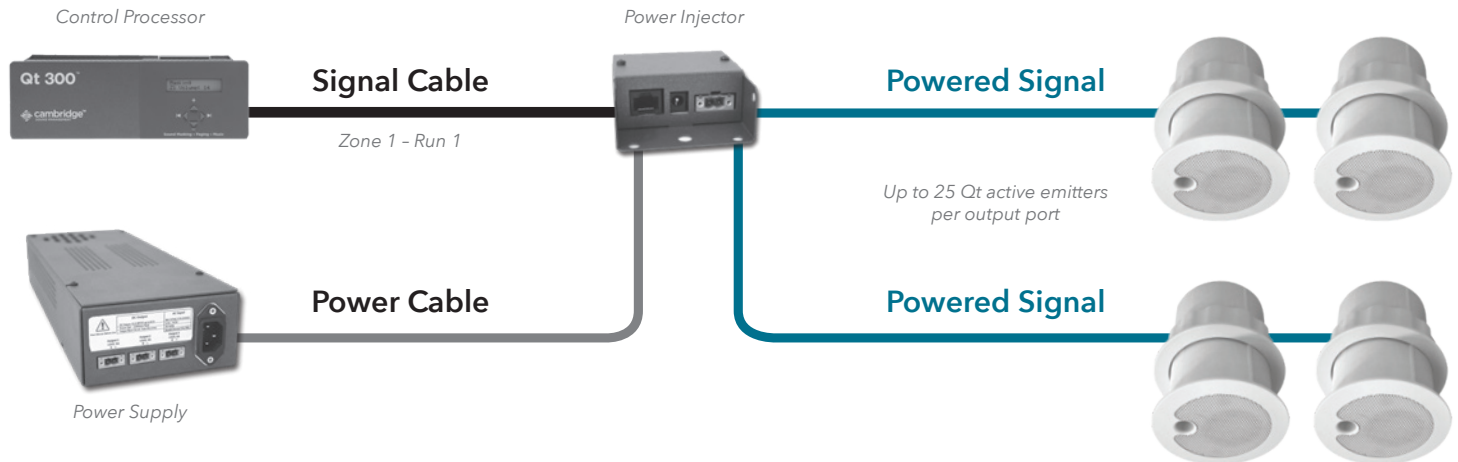

Signal Cable – Cat 3, 5, 5e, 6 UTP Category – Plenum Rated Cable

Power Cable – 14/2 Plenum Rated Cable

Powered Signal Cable – Cat 3, 5, 5e, 6 UTP Category – Plenum Rated Cable (Active Emitters ship with 16 foot cables)

ABOUT CAMBRIDGE SOUND MANAGEMENT

Cambridge Sound Management, the world's largest provider of sound masking solutions, manufactures QtPro and DynasoundPro sound masking systems to help organizations across multiple industries protect speech privacy, reduce noise distractions, and increase workplace productivity. Cambridge Sound Management's proprietary sound masking technology works by emitting a uniform, barely perceptible background sound at the frequencies of human speech. Cost effective and easy to install, their sound masking, office paging, and background music systems are deployed in hundreds of millions of square feet of space throughout the world including commercial organizations, healthcare facilities, financial services, government agencies, and educational institutions.