

DEFENDER SERIES

ENGLISH

DEUTSCH

FRANCAIS

ESPAÑOL

POLSKI

ITALIANO

DEFENDER OFFICE

The 4-channel Defender Office meets all requirements and guidelines (pursuant to Sec. 3 A1 of the German Work Safety Regulations) for professional cable protection, whether in offices, in your conference room or at your trade fair booth. You can adapt the length of the cable crossover and the 90° curve to your individual needs at any time. Like the COMPACT with BASE, this cable protector consists of two parts. Unlike all other crossovers, however, this solution does not have any connectors. In order to run a fixed line, the lid must be attached with an offset of approx. 10 cm in relation to the base. In this manner, the lid functions as a connector. The bases and lids can be shortened individually in increments of 10 mm. Both parts are marked with corresponding lines. Please follow these markings to ensure trouble-free functioning.

OFFICE	870 x 110 x 20 mm	Weight: 1.5 Kg
Safe load: Office crossover - can, however, also be driven over by cars / lorries / forklifts and lifting trucks.		
Range of application: Conceivably for all applications, but not very stable in a line, thus preferred applications are in offices, at trade fairs, etc.		



ENGINEERING DRAWING

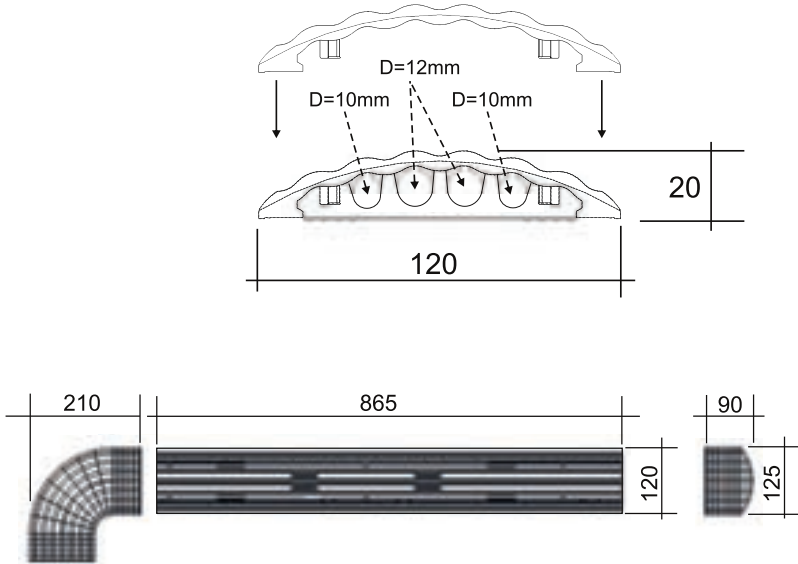

Accessories:



DEFENDER OFFICE 90° curve



DEFENDER OFFICE End ramp

ENGLISH

DEUTSCH

FRANCAIS

ESPAÑOL

POLSKI

ITALIANO

DEFENDER SERIES

ENGLISH

DEUTSCH

FRANCAIS

ESPAÑOL

POLSKI

ITALIANO

LIMITED WARRANTY

This warranty extends to the Defender branded product you purchased from Adam Hall. The statutory warranty rights against the vendor shall not be affected by this warranty. Rather, this warranty gives you additional independent claims against Adam Hall.

With this warranty, Adam Hall ensures that products you have purchased from Adam Hall or Adam Hall partners, under normal use, are free of defects in material or workmanship for a period of 5 years from the date of purchase. The warranty period begins on the date of purchase. In order to assert a claim for warranty service, the proof of date of purchase is provided by the receipt bearing the date of purchase or the date of purchase on the delivery note. You are entitled to warranty service under the conditions and provisions set out in this document, if a repair within the warranty period is required.

This warranty applies only to the original purchaser of the products supplied by Adam Hall and is not transferable to any person to whom the property is transferred by the original purchaser.

Within the warranty period, the defective parts or the product from Adam Hall will be repaired or replaced. Under the terms of this warranty, all the replaced or removed components become the property of Adam Hall.

In the unlikely event that a product acquired from Adam Hall, repeatedly exhibits a defect, Adam Hall may decide, at its discretion, to replace this product with a comparable product of at least the same performance.

Adam Hall does not guarantee that the operation of this product will be uninterrupted or error-free. Adam Hall accepts no responsibility for any damage due to incorrect compliance with the instructions received in the delivery.

This warranty does not extend to:

- wearing parts (eg battery, tubes).
 - devices that have had their serial number removed or damaged, or failed as a result of an accident
 - inappropriate or abusive use or other external causes
 - devices that were not used in accordance with the operating parameters defined in the user documentation shipped with the product
 - devices that have been repaired using parts not made or distributed by Adam Hall
 - devices that have been serviced, modified or repaired by someone other than Adam Hall or an authorised service partner.
- These terms and conditions constitute the complete and exclusive warranty agreement between you and Adam Hall regarding the Adam Hall branded product you have purchased.

This warranty is valid only within Europe. Outside of Europe please contact our official distributors.

LIMITATION OF LIABILITY

If your Adam Hall branded hardware product fails to work as warranted above, your sole and exclusive remedy shall be repair or replacement. Adam Halls' maximum liability under this limited warranty is expressly limited to the lesser of the price you have paid for the product or the cost of repair or replacement of any hardware components that malfunction in conditions of normal use.

Adam Hall is not liable for any damages caused by the product or the failure of the product, including any lost profits or savings or special, incidental, or consequential damages. Adam Hall is not liable for any claim made by a third party or made by you for a third party.

This limitation of liability applies whether damages are sought, or claims are made, under this Limited Warranty or as a tort claim (including negligence and strict product liability), a contract claim, or any other claim. This limitation of liability cannot be waived or amended by any person. This limitation of liability will be effective even if you have advised Adam Hall of an authorized representative of Adam Hall of the possibility of any such damages. This limitation of liability however, will not apply to claims for personal injury.

This Limited Warranty gives you specific legal rights. You may also have other rights that may vary from state to state or from country to country. You are advised to consult applicable state or country laws for a full determination of your rights.

REQUESTING WARRANTY-SERVICE

To request warranty service for the product, contact Adam Hall or the Adam Hall authorized reseller from which you purchased the product.