



30W Single Port Power over Ethernet Midspan IEEE802.3at Compliant Power Injector



Features

- Compliant with IEEE802.3at Standard
- Non-vented Case
- Full Protection OVP, OCP
- 1 year warranty
- Limited Power Source
- 2.5G Data Speeds
- Shielded RJ45

Applications

- IP Telephones
- Wireless Access Points
- Bluetooth® Access Points
- Security Cameras
- IP Print Servers
- WiMAX® Access Points

Safety Approvals

- cUL/UL(60950)/(62368-1)
- CB
- CCC
- BSMI
- EAC
- IRAM(TUV-s)
- CE(IEC60950-1)/(IEC62368-1)
- RCM
- NOM/NYCE
- PSB
- KC+KCC
- BIS

Mechanical Characteristics

- Length: 140mm (5.51in.)
- Width: 65mm (2.55in.)
- Height: 36mm (1.42in.)
- Weight: 0.22Kg (7.76oz)

Output Specifications

Model	AC Input	DC Output Voltage	Data Speed	Load		Regulation	
				Min.	Max.	Line	Load
POE29U-1AT(PL)D-R	C14	56V	2.5G	10mA	536mA	54-57V	

INPUT:

AC Input Voltage Rating
100 to 240VAC

AC Input Voltage Range
90 to 264VAC

AC Input Current
0.8A (RMS) maximum at 120VAC
0.55A (RMS) maximum at 240VAC

AC Input Frequency
47 to 63Hz

Leakage Current
3.5mA max

Max In-rush Current
60A max at 240VAC and max load (Cold Start at ambient 25°C)

OUTPUT:
Output Power
30W

Hold up Time
10mSec min at max load at 120VAC, 60Hz

Efficiency²
80% Typical at max load at 120VAC, 60Hz

ENVIRONMENTAL:**Temperature**

Operating	-20°C to +50°C
Non-operating	-20°C to +70°C
Relative Humidity	5 to 90%

EMI

Complies with EN55032 Class B
Complies with FCC part 15 Class B

EMC

ESD:	IEC61000-4-2 , Level 3
RS:	IEC61000-4-3, Level 3
EFT/Burst:	IEC61000-4-4, Level 2
Surge:	IEC61000-4-5, Level 3
CS:	IEC61000-4-6 , Level 3
Voltage Dips:	IEC61000-4-11
Harmonic:	IEC61000-3-2, Class A

Isolation (HI-POT)

Primary to secondary: 1500VAC for 1 minute, 10mA

Insulation Resistance

Primary to secondary: 10M Ohm 500VDC

FEATURES:**OCP/OVP/Short Circuit Protection**

OCP: ≤750mA Max

OVP: Latching

Short Circuit: The output can be shorted permanently without damage. Non-latching auto recovery.

Indicator

Solid Green: unit has detected a IEEE802.3at or af load/PD

Blinking Green: Power “ON” ready for connection

Fast Blinking Amber/Green: Invalid load connected

Slow Blinking Amber/Green: fault

AC Input Connector

IEC320 C14 - three wire

Output Connection

+pins 3,6 / -pins 1,2

Data IN/POE OUT Connector

Shielded RJ45

Notes:

1. The characteristics defined are at ambient temperature of 25°C unless otherwise specified
2. Efficiency is measured after 30minutes burn-in

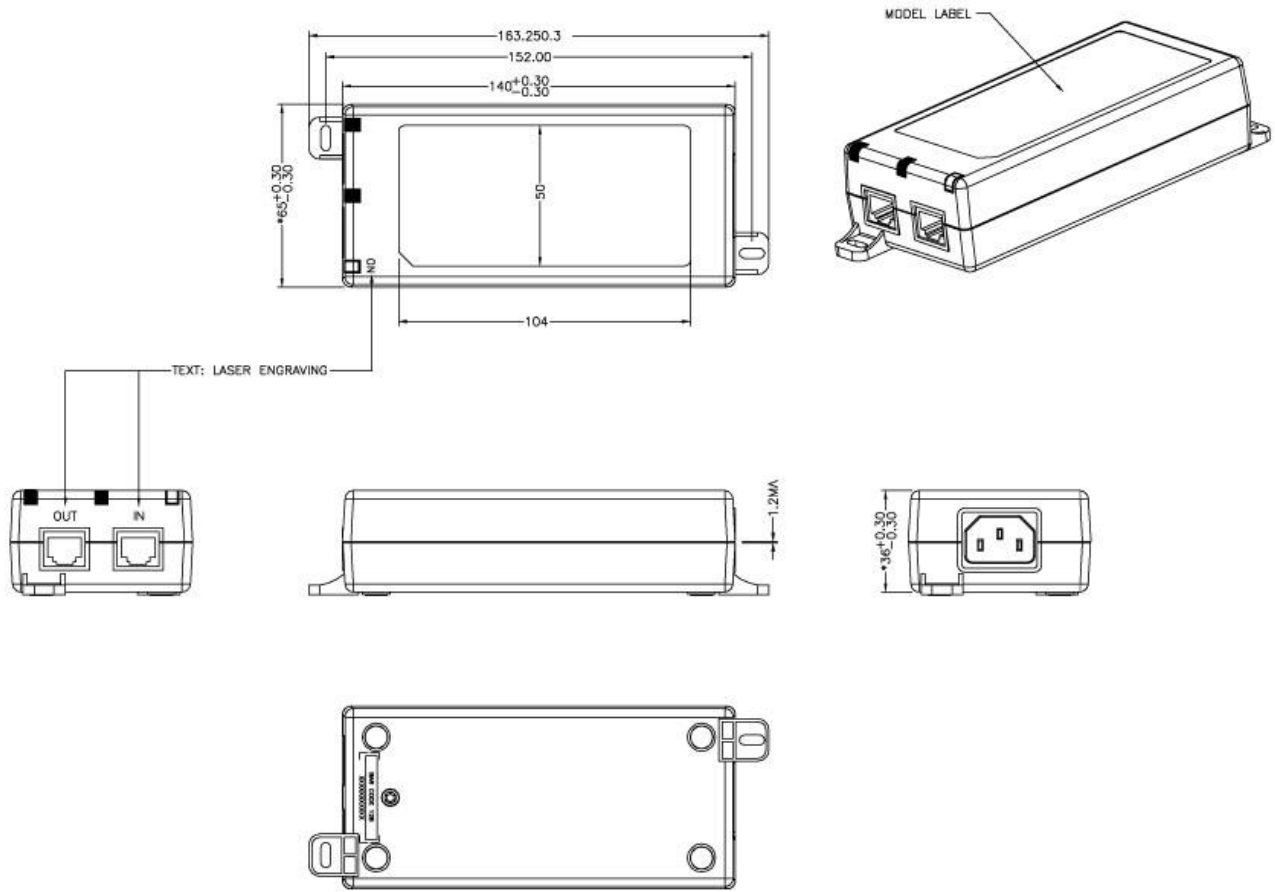

**Supplier's Declaration of Conformity
47 CFR § 2.1077 Compliance Information**

Phihong USA Corporation
47800 Fremont Boulevard
Fremont, CA 94538
Telephone: (510) 445-0100
www.phihong.com

NOTE: This model has/The models in this products series have been tested and found to comply with the limits for a Class B digital device, pursuant to part 15 of the FCC Rules. These limits are designed to provide reasonable protection against harmful interference in a residential installation. This equipment generates, uses and can radiate radio frequency energy and, if not installed and used in accordance with the instructions, may cause harmful interference to radio communications. However, there is no guarantee that interference will not occur in a particular installation. If this equipment does cause harmful interference to radio or television reception, which can be determined by turning the equipment off and on, the user is encouraged to try to correct the interference by one or more of the following measures:

- Reorient or relocate the receiving antenna.
- Increase the separation between the equipment and receiver.
- Connect the equipment into an outlet on a circuit different from that to which the receiver is connected.
- Consult the dealer or an experienced radio/TV technician for help.

Changes or modifications to equipment not expressly approved by PHIHONG could void the user's authority to operate the equipment.