

POWERBASS-8TN

SUBWOOFER SPEAKER WITH 100 V LINE TRANSFORMER

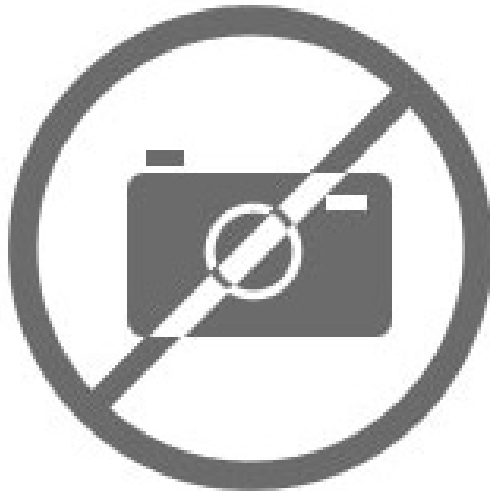

DESCRIPTION

Subwoofer speaker with 100 V line transformer

Subwoofer with excellent bass response, for sound reinforcement in ambient music.

Improves the bass content of the music, offering deep and powerful bass without distortion.

Unique FONESTAR design, with stylised shapes and compact size. Available in black or white.

Can be installed on the floor or wall and easily goes unnoticed in any space.

Fully protected loudspeaker.

Several options for transformer power selection and low impedance connection that allows it to be adapted to any installation.

It incorporates a low pass filter, which allows its frequency response to be adjusted according to the type of music and features of the premises.

Bass reflex reinforcement, which takes advantage of the rear radiation of the loudspeakers to boost the bass.

Perfect for ambient music applications for the retail sector, bars, cafés, etc .



Expand product information on:

<https://fonestar.com/es/POWERBASS-8TN>

TECHNICAL CHARACTERISTICS

| | |
|-------------------|---|
| FEATURES | <p>Subwoofer speaker for background music applications. Excellent bass response for reinforcement of bass music content. Bass-reflex reinforcement system. Unique FONESTAR design. 100/70 V line driver and low impedance. Wall or floor/shelf installation.</p> |
| POWER | <p>120 W RMS (IEC 60258-5 Average rated power, 100 hours)</p> |
| LOUDSPEAKERS | <p>1 x 8" subwoofer</p> |
| RESPONSE | <p>47-300 Hz (-10 dB) @ FPB 150 Hz 47-400 Hz (-10 dB) @ FPB 400 Hz 47-650 Hz (-10 dB) @ Bypass</p> |
| IMPEDANCE | <p>120 W RMS @ 100 V (83 Ohm) 85 W RMS @ 70 V (57 Ohm) 60 W RMS @ 100 V/70 V (166 Ohm/83 Ohm) 30 W RMS @ 100 V/70V (333 Ohm/166 Ohm) 15 W RMS @ 100 V/70 V (666 Ohm/333 Ohm) 7.5 W RMS @ 70 V (666 Ohm) Low Z: 6 Ohm</p> |
| SENSITIVITY | <p>85 dB @ 1 W/1 m</p> |
| SOUND PRESSURE | <p>103 dB @ rated power/1 m</p> |
| SWITCH | <p>W selector in high Z and low Z Low pass filter selector: 150 Hz / 400 Hz / Bypass</p> |
| MATERIAL | <p>MDF</p> |
| CONNECTORS | <p>Euroblock input and output</p> |
| TEMPERATURE RANGE | <p>Operation: -10°C ~ 50°C Storage: -20°C ~ 50°C</p> |



Expand product information on:
<https://fonestar.com/es/POWERBASS-8TN>

| | |
|-------------|---|
| COLOUR | Black (RAL 9005) |
| DIMENSIONS | 545 x 150 x 337 mm depth |
| WEIGHT | 9.4 kg |
| ACCESSORIES | Wall mounting brackets Screws and mounting accessories |
| OPTIONAL | Ceiling mount POWERBASS-CMB |



Expand product information on:
<https://fonestar.com/es/POWERBASS-8TN>

Impedance vs Frequency

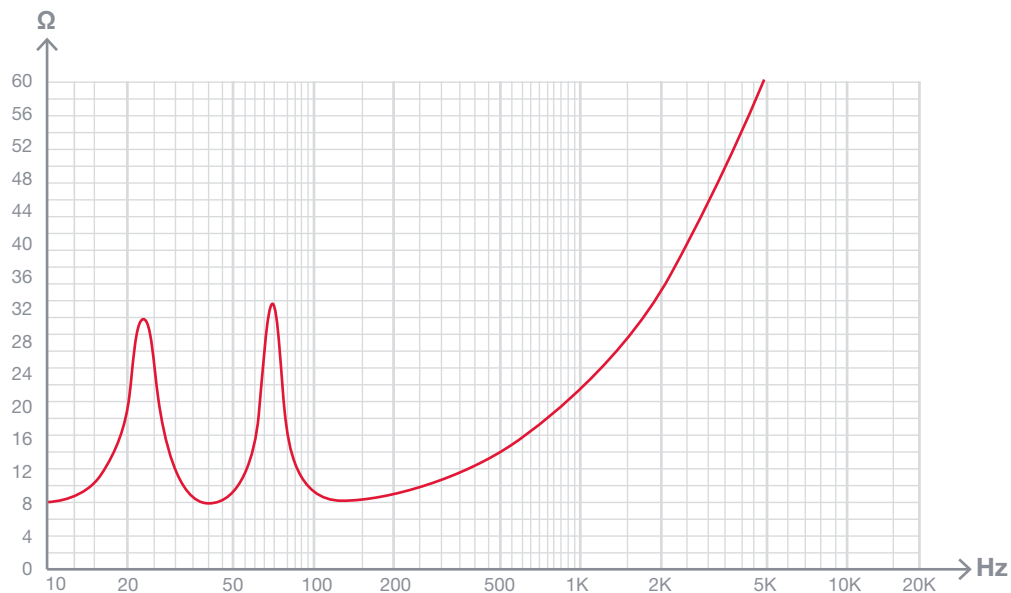

SPL vs Frequency

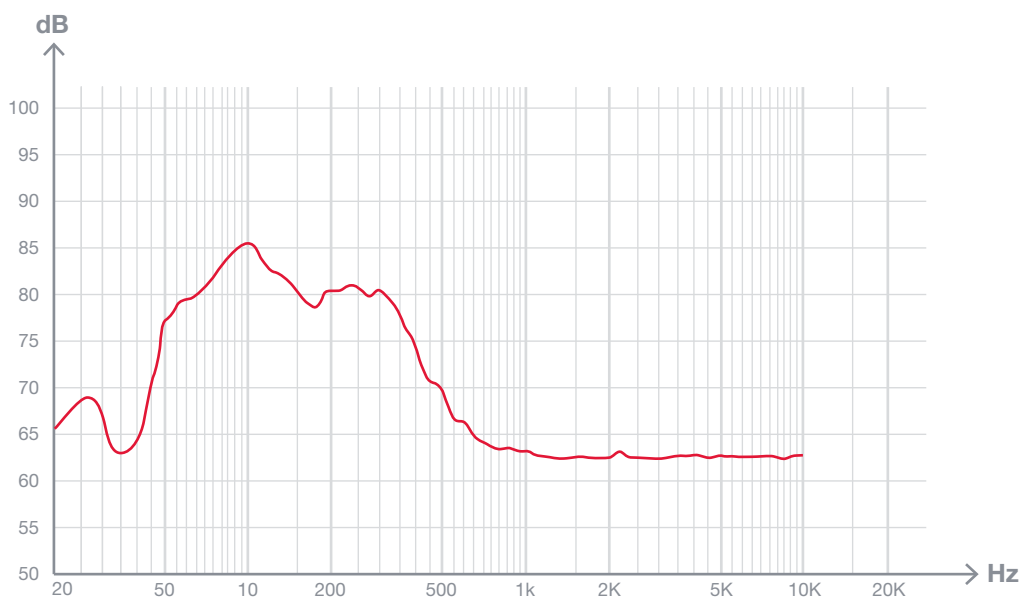

Amplia la información de los productos en:
<https://fonestar.com/es/POWERBASS-8TB>

Electric diagram

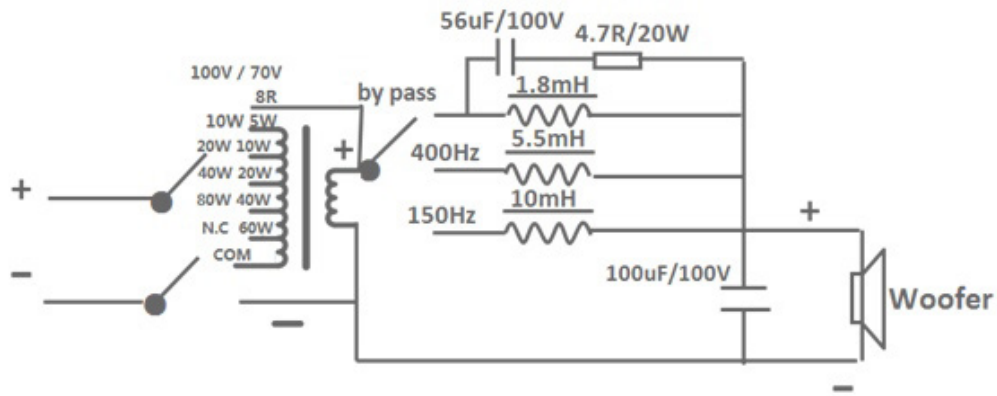

Amplia la información de los productos en:
<https://fonestar.com/es/POWERBASS-8TB>