



RL-1

Installation Guide v6.0

Cloud Electronics Limited

140 Staniforth Road, Sheffield, S9 3HF England

Tel +44 (0) 114 244 7051

Fax +44 (0) 114 242 5462

E-mail: info@cloud.co.uk

Web site <http://www.cloud.co.uk>

RL-1 Installation Guide

1 Introduction

The RL-1 remote control plate can be wired to a wide range of Cloud products and the way in which the RL-1 is connected does depend upon the product. This document will guide you to the correct wiring diagram to connect the RL-1 to your specific host unit connector and detail any switches or jumpers that may need to be reconfigured.

2 Hardware and Wiring Requirements

The Cloud RL-1 remote control plate is the same physical size as a single UK electrical light switch and can be mounted in a 25mm deep housing. The RL-1 should be connected to the remote connector of the host mixer or amplifier using 2-Core cable with an overall screen. The RL-1 terminations are conventional screw terminals while the remote input on the host unit is a plug-in screw terminal type connector (connector is supplied with the mixer/amplifier).

Note: Maximum recommended cable length is 100m (328ft)

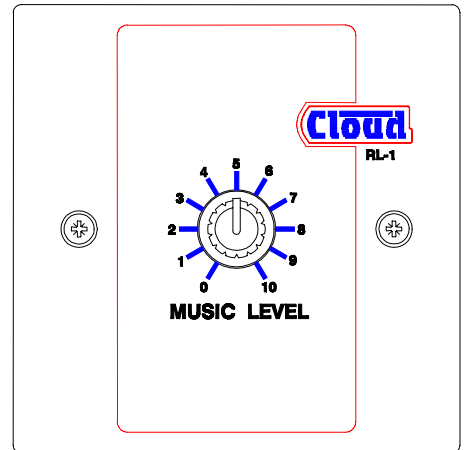

3 RL-1A

The RL-1A is available for the American market, it has identical operation to the RL-1 but is designed to fit a single gang US electrical outlet box. Front panel dimensions are 4 1/2" x 2 3/4"

4 Specific Product Information

Some Cloud products have external switches and internal jumpers that may require reconfiguring for an RL-1 to operate, this document contains the jumper settings, location and function for relevant products. Please take some time to read the applicable information here as these settings can be critical to the operation of an RL-1. To find the relevant wiring schematics for the product you are using, locate the mixer/amplifier in the following list. You will see two letters that refer to the wiring diagrams found later in sections 5 and 6.

4a CX133

All schematics are at the rear of the document.

Single Zone Schematic A (Stereo) B (Mono-Split)

Multiple Zone Schematic F

Note: Jumper J1 configures zone 2 for stereo/mono operation

Jumper J3 configures zone 2 for stereo/mono operation

The factory default setting for both zones is 'STEREO'. When a zone is in mono mode it has two identical mono outputs with the option to control the left and right independently (see single zone schematic B)

Jumper Settings to Defeat the Front Panel Music Level Control

Zone 1: J4 can be set to 'DEF' to defeat the front panel music level control (Optional).

Zone 2: J2 can be set to 'DEF' to defeat the front panel music level control (Optional).

Jumper Locations

Front Left Hand Side

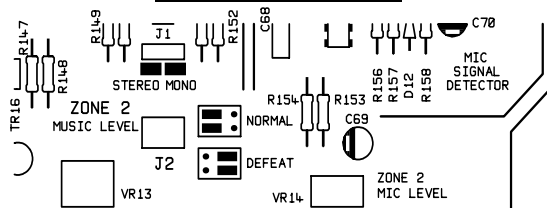

Front Right Hand Side

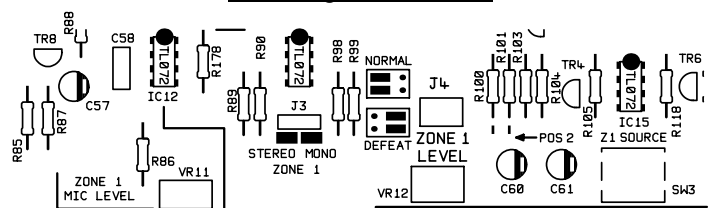

4b CX-A4

All schematics are at the rear of the document.

Single Zone Schematic D

Multiple Zone Schematic G (Only when linking 3 or more channels, see 'SOLO/LINK switch')

Notes:

Remote control can only be achieved when the CX-A4 is fitted with either the VCA-2 or VCAL-1 two-channel internal remote control module (two modules will be needed for control of all four channels).

SOLO/LINK Switch = When depressed, a single RL-1 can be wired to control a single channel of the amplifier. If the switch is released, a single RL-1 wired to the left connector of the pair (viewed from the rear of the amplifier) will control both channels simultaneously. Simultaneous control of four channels from a single RL-1 requires both switches to be depressed and the two left hand connectors to be linked together as shown in multiple zone schematic 'G'.

4c CX-A6

All schematics are at the rear of the document.

Single Zone Schematic D

Multiple Zone Schematic G (Only when linking 3 or more channels, see 'SOLO/LINK switch')

Notes:

Remote control can only be achieved when the CX-A6 is fitted with either the VCA-2 or VCAL-1 two-channel internal remote control module (three modules will be needed for control of all six channels).

SOLO/LINK Switch = When depressed, a single RL-1 can be wired to control a single channel of the amplifier. If the switch is released, a single RL-1 wired to the left connector of the pair (viewed from the rear of the amplifier) will control both channels simultaneously. Simultaneous control of four channels from a single RL-1 requires all three switches to be depressed and the two left hand connectors to be linked together as shown in multiple zone schematic 'G'.

4d CX-A450

All schematics are at the rear of the document.

Single Zone Schematic C

Multiple Zone Schematic G

Remote control can only be achieved when the CX-A450 is fitted with the VCA-5 internal remote control module (four modules will be needed for control of all 4 channels).

4e CX-A850

All schematics are at the rear of the document.

Single Zone Schematic C

Multiple Zone Schematic G

Remote control can only be achieved when the CX-A850 is fitted with the VCA-5 internal remote control module (eight modules will be needed for control of all 8 channels).

4f MPA-626

All schematics are at the rear of the document.

Single Zone Schematic D

Jumper Settings to configure the MPA-626 for an RL-1

When using an RL-1 with the MPA-626, jumper J12 can be set in the 'DISABLE' position to defeat the front panel music level control if preferred.

Jumper Location

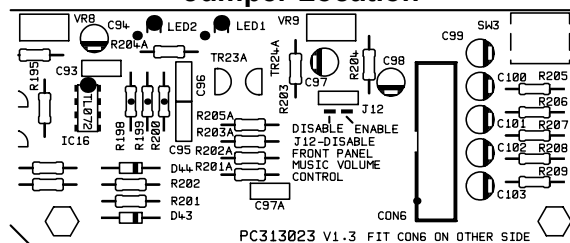

4g CX242

All schematics are at the rear of the document.

Single Zone Schematic E

Multiple Zone Schematic H

Zones 1 & 2 each have the following switches located behind the tamperproof front panel:

REM = This front panel switch controls whether music level and music source are to be controlled via remote control plate or the front panel control.

MONO = A simple front panel switch that allows the stereo output of either zone to be reconfigured to a mono signal output. In this mode each zone will have two independent mono outputs.

IN STEREO MODE: The RSL-1 must be used, you cannot use an RL-1.

IN MONO MODE: The RL-1 can be used with local control selected at the REM switch. In this scenario the RL-1 will control the right output of the associated zone, and the left output will be controlled by the music level control on the front panel.

4h Z4 & Z8

All schematics are at the rear of the document.

Single Zone Schematic E

Multiple Zone Schematic H

Jumper and Switch Settings to configure the Z4/8 for an RL-1

On any zone where an RL-1 is to be used the rear panel ‘music control’ switch should be depressed and jumper J1 should be in the ‘FR’ position.

Jumper Locations

Z4II & Z8II Zone Board

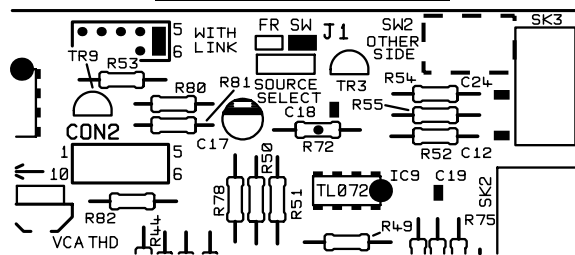

Z4 & Z8 (Old Model) Standard Zone Board

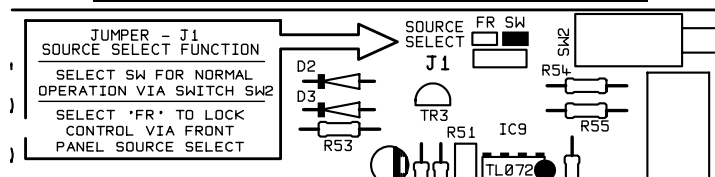

Z4 & Z8 (Old Model) Enhanced Zone Board (w/facility)

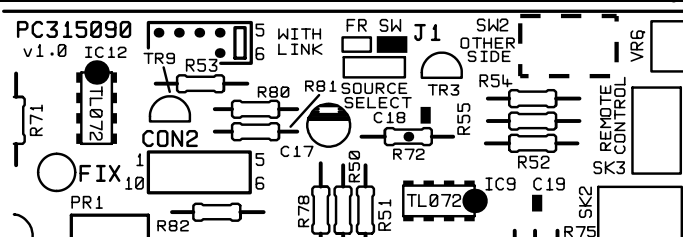

4i 36/50

All schematics are at the rear of the document.

Single Zone Schematic E

Multiple Zone Schematic H

Jumper and Switch Settings to configure the 36/50 for an RL-1

Zone 1: To use an RL-1 depress the ‘music control’ switch and set jumper J6 to the ‘FR’ position.

Zone 2: To use an RL-1 depress the ‘music control’ switch and set jumper J7 to the ‘FR’ position.

Jumper Locations

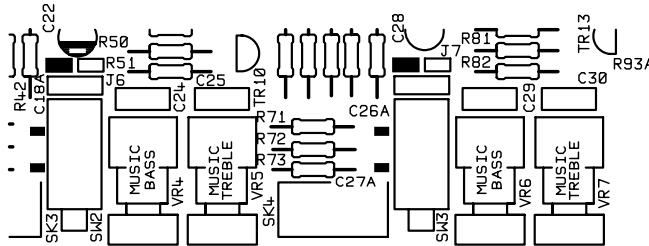

4j 46/50

All schematics are at the rear of the document.

Single Zone Schematic E

Multiple Zone Schematic H

Jumper and Switch Settings to configure the 46/50 for an RL-1

On any zone where an RL-1 is to be used the rear panel ‘music control’ switch should be depressed and the relevant jumper (see list below) must be in the ‘FR’ position.

- Zone 1 = J3
- Zone 2 = J4
- Zone 3 = J5
- Zone 4 = J6

Jumper Locations on the 46/50 PCB

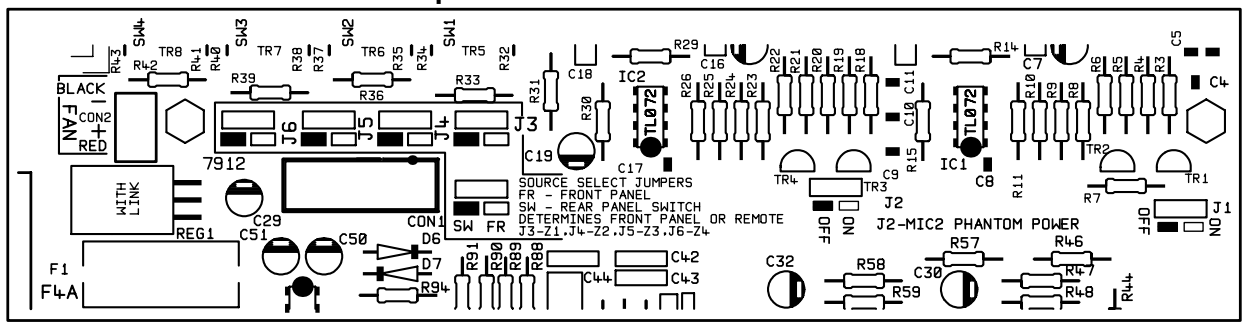

5 Single Zone Schematics

Information regarding which schematic can be used with a specific Cloud product can be found in the ‘Product Specific Information’ section

A

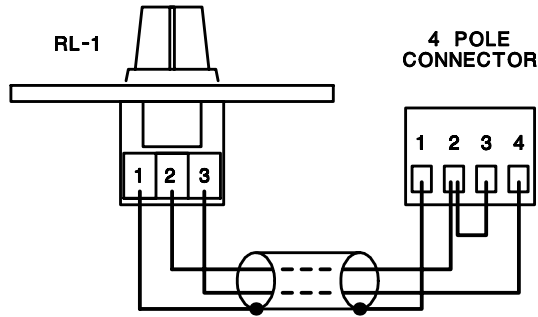

B

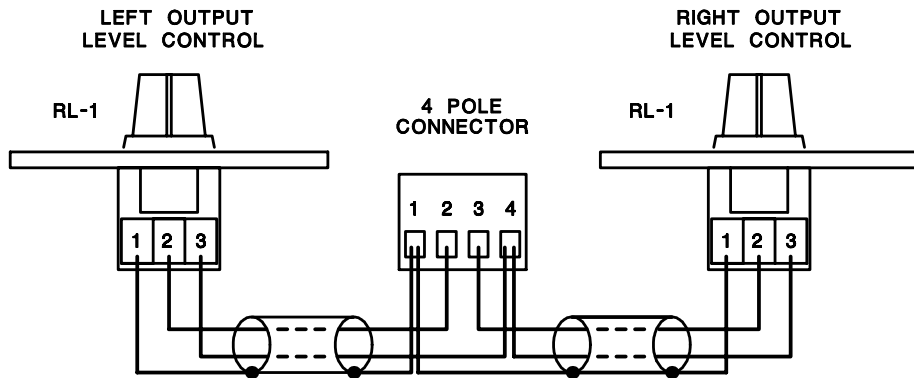

C

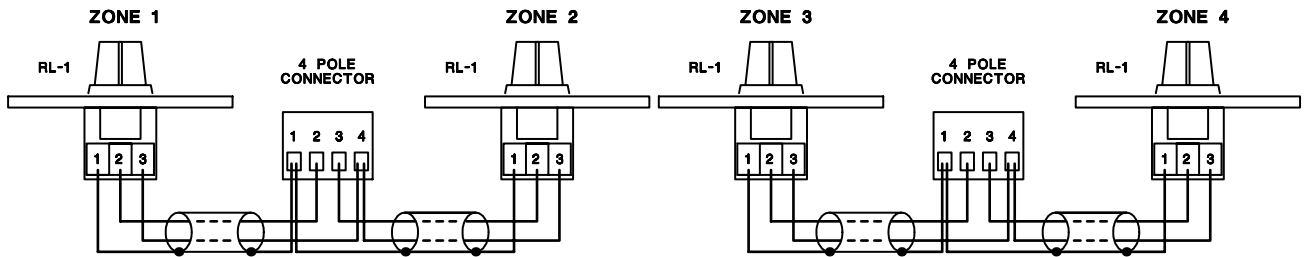

D

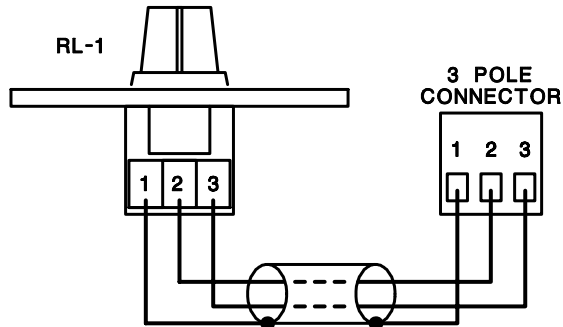

E

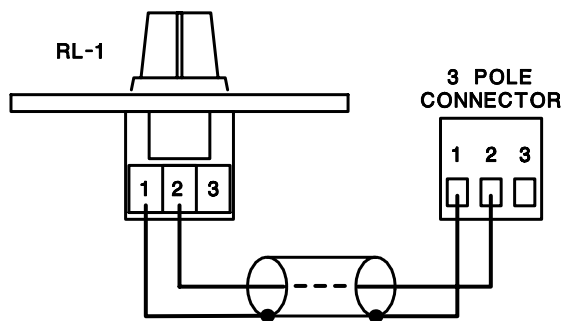

6 Multiple Zone Schematics

Information regarding which schematic can be used with a specific Cloud product can be found in the 'Product Specific Information' section

You should be aware that when connecting a single RL-1 to control the music level of multiple zones, the action of the level control will degrade resulting in an uneven operation. The effect is more pronounced the more zones that are used. In many circumstances this effect will be minor and often acceptable.

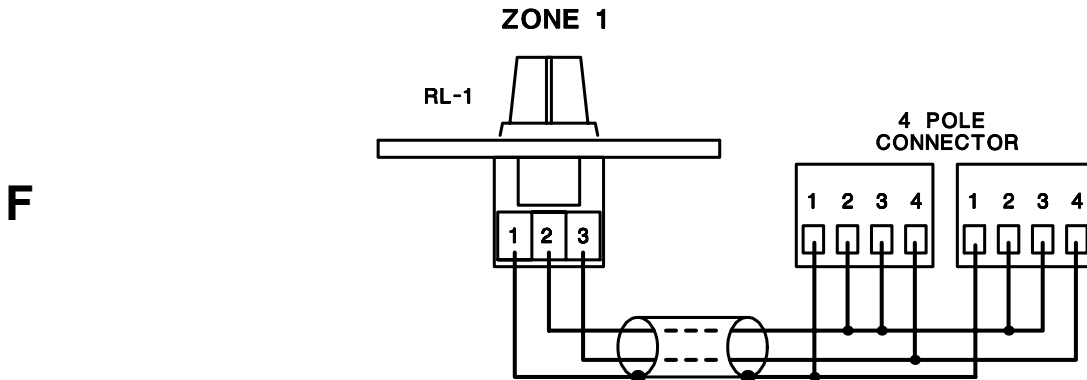

To control a second zone simultaneously link all 4-wires in parallel from the previous connector to the next, for example the diagram above shows how to link 2 zones for simultaneous operation from a single RL-1.

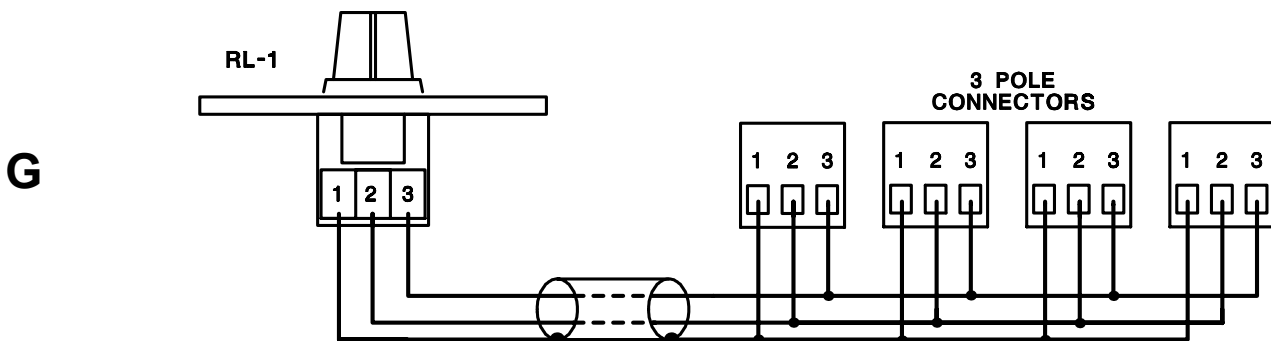

To control a second zone simultaneously link all 3-wires in parallel from the previous connector to the next, for example the diagram above shows how to link 4 zones for simultaneous operation from a single RL-1.

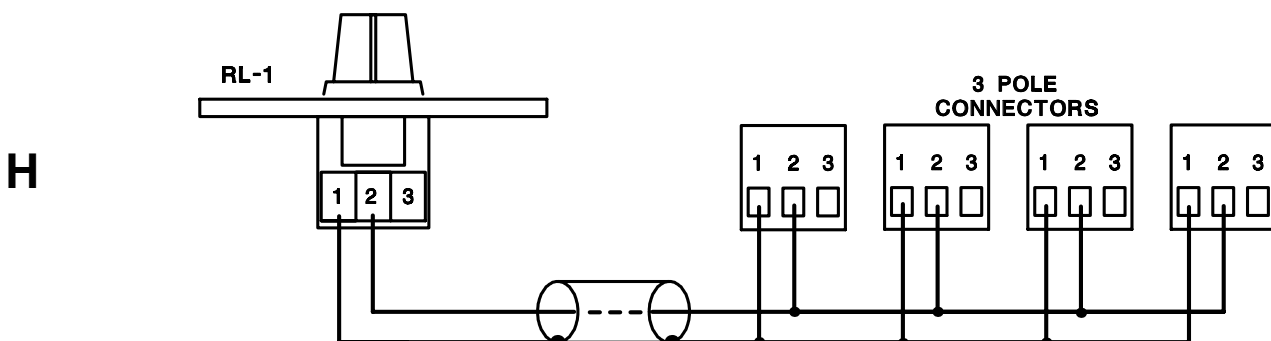

To control a second zone simultaneously link both wires (Pin 1 and Pin 2) in parallel from the previous connector to the next, for example the diagram above shows how to link 4 zones for simultaneous operation from a single RL-1.

Should you have any further questions please do not hesitate to contact our technical support staff (contact details on front cover)