

# SM27 Cardioid Condenser Microphone

## Overview

The SM27 is a rugged and versatile large-diaphragm, side-address cardioid condenser microphone, with low self-noise and extended frequency response that picks up vocal and instrument nuances with clarity. Durable Shure construction features three separate mesh layers that reduce wind and breath noise. Equally comfortable on stage or in the studio.

## Features

- Cardioid polar pattern – the most commonly used pattern for both studio and live applications
- 1 inch, externally biased, ultra-thin, 2.5  $\mu\text{m}$ , 24 Karat gold-layered, low mass, Mylar<sup>®</sup> diaphragm provides superior transient response
- Class A, discrete, transformerless preamplifier for transparency, extremely fast transient response and no crossover distortion, while minimizing harmonic and intermodulation distortions
- Premium electronic components and gold-plated internal and external connectors
- Subsonic filter eliminates rumble from mechanical vibration below 17 Hz
- Switchable 15 dB pad for handling extremely high sound pressure levels (SPLs)
- 3-position switchable low-frequency filter helps reduce unwanted background noise or counteract proximity effect
- Integrated three-stage pop protection grille reduces plosives and other breath noise
- Internal shock mount reduces handling and stand noise

## Available Models

SM27	Includes stand adapter and zippered pouch
------	---



SM27

## Specifications

<b>Type</b>	Condenser (externally biased)
<b>Frequency Response</b>	20 to 20,000 Hz
<b>Polar Pattern</b>	Cardioid
<b>Impedance</b>	150 $\Omega$ (140 $\Omega$ actual)
<b>Sensitivity</b> (at 1 kHz, Open circuit voltage)	-37 dBV/Pa 1 Pascal=94 dB SPL
<b>Maximum SPL</b> (1 kHz at 1% THD)	1000 $\Omega$ load: 133 dB (147 dB, Pad on) 2500 $\Omega$ load: 138 dB (152 dB, Pad on)
<b>Signal-to-Noise Ratio</b> (referenced at 94 dB SPL at 1 kHz)	84.5 dB S/N ratio is difference between 94 dB SPL and equivalent SPL of self noise, A-weighted
<b>Dynamic Range</b> (at 1 kHz)	1000 $\Omega$ load: 123 dB 2500 $\Omega$ load: 128 dB
<b>Common Mode Rejection</b> (20 Hz to 20 kHz)	> 50 dB
<b>Clipping Level</b> (20Hz-20 kHz at 1% THD)	1000 $\Omega$ load: 1 dBV 2500 $\Omega$ load: 7 dBV THD of microphone preamplifier when applied input signal is equivalent to cartridge output at specified SPL
<b>Self Noise</b> (typical, equivalent SPL, A-weighted)	9.5 dB
<b>Polarity</b>	Positive pressure on diaphragm produces positive voltage on pin 2 with respect to pin 3
<b>Weight</b>	642 g
<b>Switch</b>	Attenuator: -15 dB Low frequency response: flat; -6 dB/octave below 115 Hz; -18 dB/octave below 80 Hz
<b>Connector</b>	Three-pin professional audio (XLR), male
<b>Power Requirements</b>	48 Vdc phantom, 5.4 mA

## Optional Accessories and Replacement Parts

<b>A27SM</b>	Shure lock <sup>™</sup> rubber isolated shock mount	<b>A322B</b>	Zippered pouch	<b>A32WS</b>	Windscreen
<b>RPM642</b>	Replacement rubber rings for shock mount (contains four)	<b>PS6</b>	Popper stopper <sup>™</sup>		

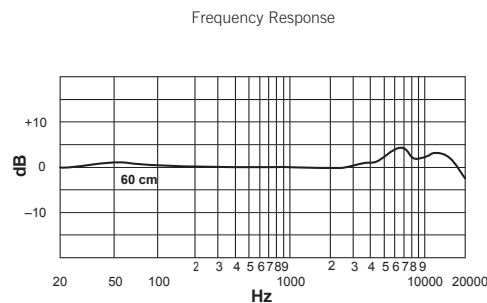
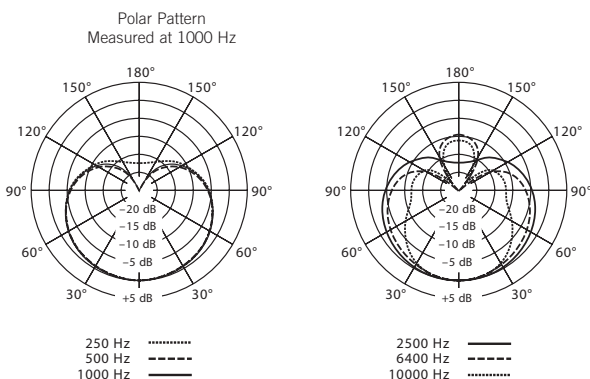

**SHURE**<sup>®</sup>  
LEGENDARY  
PERFORMANCE<sup>™</sup>