

UCL product information sheet

Product Specifications

Fits most: 32" to 50" flat panels

Supports up to: 125 lbs (56.7 kg)

Tilt: -20° to +25°

Mounting profile: 5.7" (145mm)

Maximum extension: 25.5" (648mm)

Universal & VESA compliant: 100x100, 100x200, 200x200, 200x300, 300x400, 400x400, 400x600, 400x800

Mounting: Double-stud

Color: Black and Platinum

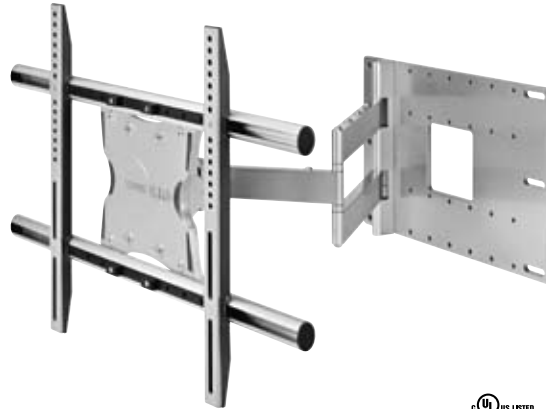

© 2015 OMNI MOUNT

Product Benefits

- Tilt, pan and swivel for optimum viewing
- Arms nest for low mounting profile
- Includes universal adapter with two sets of rails for greater panel compatibility
- Lateral arm adjustment
- Built-in screen leveling
- Lift n' Lock™ for easy installation
- Locking system for added safety
- Includes complete Grade 5 hardware kit

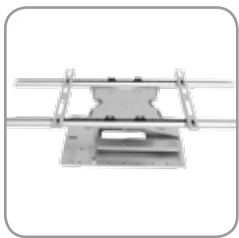

The UCL comes fully assembled right out of the box for fast installation.

Series

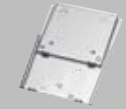

QM100 F



QM100 T

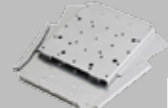

QM200 F



75/100 FD



75/100 CL

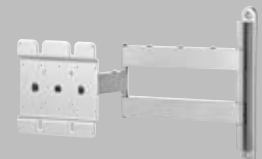

FP-CL

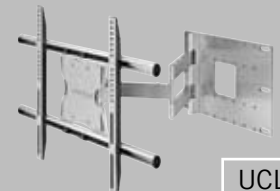

UCL



OmniMount, an innovator of A/V mounts and furniture for more than a quarter century, is the choice of professional installers and the brand most recommended by flat panel manufacturers. The Classic Series is a full line of fixed, tilt, flip down and cantilever mounting solutions designed with simplicity and affordability in mind. The UCL is a large cantilever mount that is the obvious choice for basic installations.





OmniMount, an innovator of A/V mounts and furniture for more than a quarter century, is the choice of professional installers and the brand most recommended by flat panel manufacturers. The Classic Series is a full line of fixed, tilt, flip down and cantilever mounting solutions designed with simplicity and affordability in mind. The UCL is a large cantilever mount that is the obvious choice for basic installations.

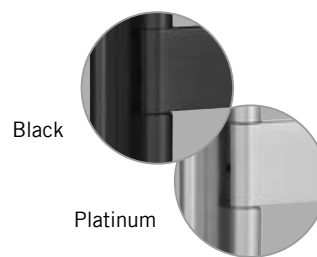
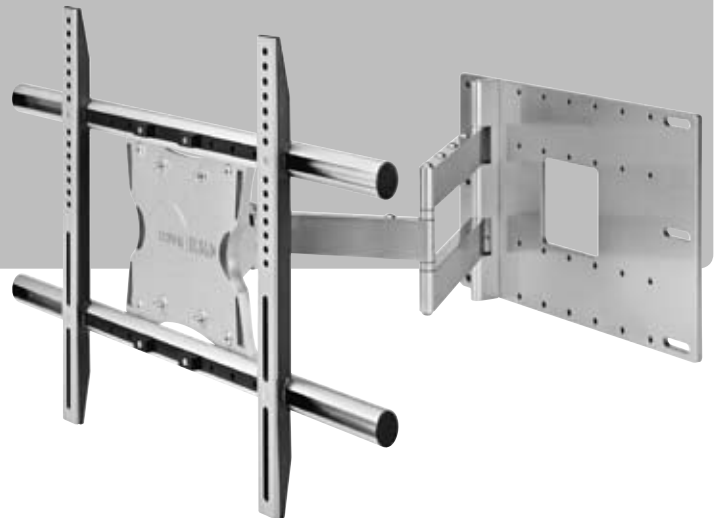

Product Specifications

Fits most: 32" to 50" flat panels

Supports up to: 125 lbs (56.7 kg)

Tilt: -20° to +25°

Mounting profile: 5.7" (145mm)

Maximum extension: 25.5" (648mm)

Universal & VESA compliant: 100x100, 100x200, 200x200, 200x300, 300x400, 400x400, 400x600, 400x800

Mounting: Double-stud

Color: Black and Platinum

Product Benefits

- Tilt, pan and swivel for optimum viewing
- Arms nest for low mounting profile
- Includes universal adapter with two sets of rails for greater panel compatibility
- Lateral arm adjustment
- Built-in screen leveling
- Lift n' Lock™ for easy installation
- Locking system for added safety
- Includes complete Grade 5 hardware kit

	Color	Stock Code	Packaging UPC	MC UPC
Americas	Black	1001537BLACK	728901018350	NA
International	Black	1003523-1	728901019906	NA
Americas	Platinum	1001537FE-1	728901011184	NA
International	Platinum	1002359-1	728901013157	NA

	Dimensions WxDxH inches (mm)	Wt lbs (kg)
Product Box	33.1 x 18.9 x 5.9 (840x480x148)	42.1 (19.1)
Master Carton	NA	NA

Box Contents	Qty
Cantilever mount	1
Vertical rail	2
Extension rail	2
Rail covers	12

Box Contents	Qty
Complete mount installation hardware kit	1
Complete panel attachment hardware kit	1
Instruction manual	1
Flat panel compatibility chart	1

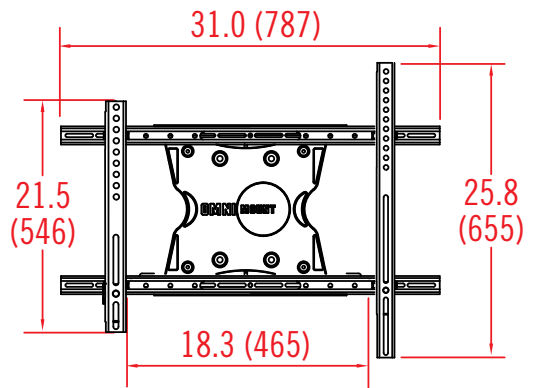
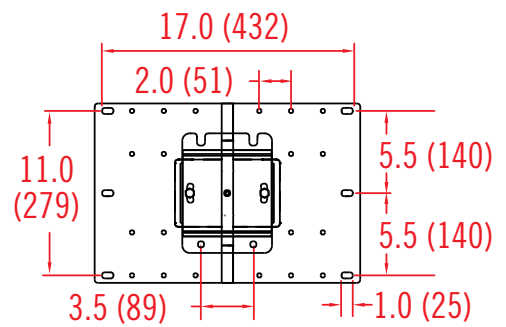
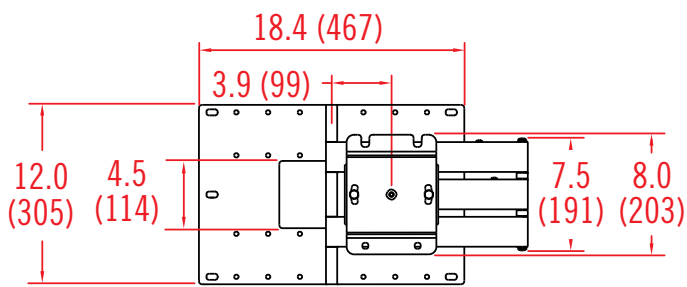
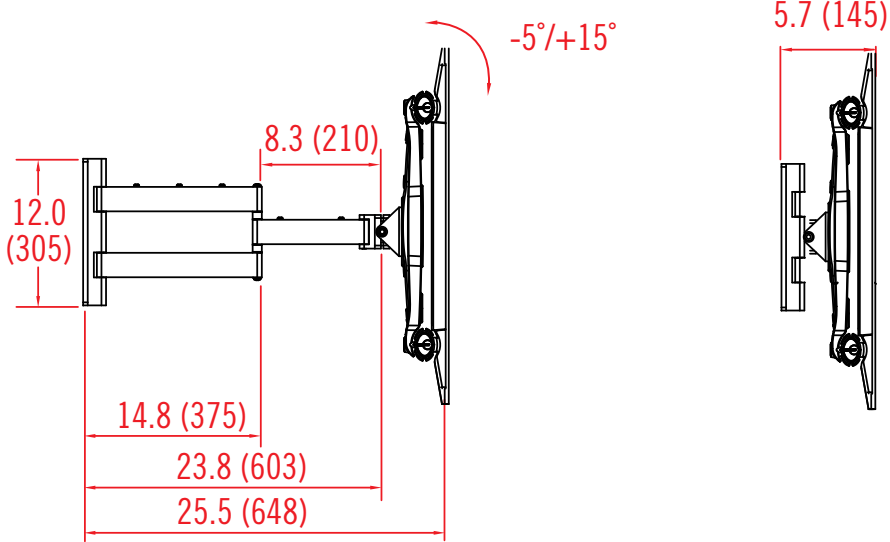

Universal adapter dimensions

inches (mm)