

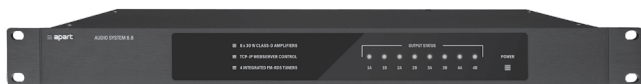

AUDIOSYSTEM8.8
Instruction manual

AUDIOSYSTEM8.8



Safety information

- Please check the carton box for any kind of damage on reception of the goods. In case of a damaged carton, please contact your dealer before opening the carton.
- !!!! Danger !!!! Exposure to high sound levels may cause a permanent hearing loss. Individuals vary considerably to sound pressure level induced hearing loss but nearly everyone will lose some hearing if exposed to high sound pressure levels for a sufficient amount of time. Therefore it is recommended that all persons exposed to equipment capable of producing high sound pressure levels, such as this device, be protected by hearing protection while installing or operating this unit.
- Read all documentation before operating your equipment.
- Keep all documentation for future reference.
- Save the carton and packing material even if the equipment has arrived in good condition.
- Should you ever need to ship the unit, use only the original factory packing.
- Do not spill water or other liquids into or on the unit.
- Make sure power outlets are conform to the power requirements listed on the back of the unit.
- Do not use the unit if the electrical power cord is frayed or broken.
- Always operate the unit with the AC ground wire connected to the electrical system ground.
- Do not connect the inputs / outputs of amplifiers or consoles to any other voltage source, such as a battery, mains source, or

power supply, regardless of whether the amplifier or console is turned on or off.

- Power down & disconnect units from mains voltage before making connections.
- Do not use the unit near stoves, heat registers, radiators, or other heat producing devices.
- Do not operate equipment on a surface or in an environment which may distort the normal flow of air around the unit. If the unit is used in an extremely dusty or smoky environment, the unit should be periodically “blown free” of dust.
- Do not remove the cover. Removing the cover will expose you to potentially dangerous voltages.
- Do not drive the inputs with a signal level higher than that required to drive equipment to full output.
- Do not run the output of any amplifier back into another input.
- In case of mal-function this device should be serviced by qualified service personnel only.
- The apparatus may not be exposed to dripping or splashing and no objects filled with liquids may be placed on the apparatus.
- The appliance coupler has to be readily operable to disconnect the device.

Caution

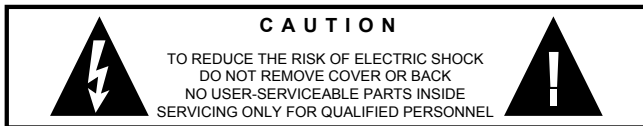

CAUTION: a clipped or distorted audio signal at the input (overload) will come out as a clipped or distorted signal at the output, regardless of the output level and DSP processing power applied to the signal. Clipping occurs when the signal and/or the applied gain is too high, due to incompatibility of the signal level, a faulty source, an impedance mismatch or a human error. Therefore, monitor incoming signals and do not overload the inputs. Adjust the output level(s) and gain settings of your source(s) if necessary. Due to the internal gain structure of the AUDIOSYSTEM, the output signals may clip even when the input signals are relatively low. Do not over amplify audio signals. Boosting certain frequency bands or over compressing incoming audio signals may cause signal clipping, distortion and excessive noise at the output. If you have to add lots of gain, your incoming signal may be too weak.

NOTE: This is the out-of-the-box manual of your AUDIOSYSTEM8.8. A full manual and GUI guide can be found on our website. If you want customized configurations, adjustments and a total solution for your specific application, please seek the online manual.

The apart-team hopes you enjoy our product. We enjoyed developing this product and guarantee it will serve as a solution for every kind of implementation.

General Description

AUDIOSYSTEM8.8 is an audio matrix with 4 stereo line inputs, 4 stereo D-class amplified outputs and 2 stereo line outputs (copies of amplified outputs). The AUDIOSYSTEM8.8 also has 4 stereo FM RDS tuners built-in. Together with this the AUDIOSYSTEM8.8 has a paging input and an emergency mute.

The unit may be controlled through our DIWAC wall panels and has a built-in webserver for TCP/IP connection for system integration and/or control through any mobile device or computer that has a web browser installed.

Features

- Internal webserver GUI for configuration and use
- TCP/IP
- Fixed architecture
- Stand alone operation
- Online upgradeable firmware
- Configurable mono/stereo zones
- 4 stereo unbalanced line inputs using RCA connectors
- 2 stereo unbalanced line outputs using RCA connectors
- 8 x 30 watts class-D amplifier outputs (6 - 8 ohms)
- Up to 8 DIWAC wall controls (maximum 2 controls per output zone)
- LED display for zone status overview
- Import / export function
- 8 integrated chimes
- Universal integrated switching power supply: 85-264 Vac / 47-63 Hz
- Removable 19" rack ears

Out of box behavior

Standard factory configuration:

Input Configuration:

- 4 stereo inputs: AUX1 (1A & 1B), AUX2 (2A & 2B), AUX3 (3A & 3B) and AUX4 (4A & 4B).

Output Configuration:

- 4 stereo outputs: output 1 (1A & 1B), output 2 (2A & 2B), output 3 (3A & 3B) and output 4 (4A & 4B).

Wall panel(DIWAC) configuration:

- Pushbuttons ∇ \blacktriangle for source selection (AUX 1 - 4) and \pm for volume control (0 - 50).
- DIWAC 1A - 1B for output 1, 2A - 2B for output 2, 3A - 3B for output 3 and 4A - 4B for output 4
- Out of the box there are no FM presets configured but they may be accessed and configured through the control menu. The control menu is accessed by pressing ∇ $+$. In the control menu it is possible to set EQ settings, set default settings and do an FM scan.

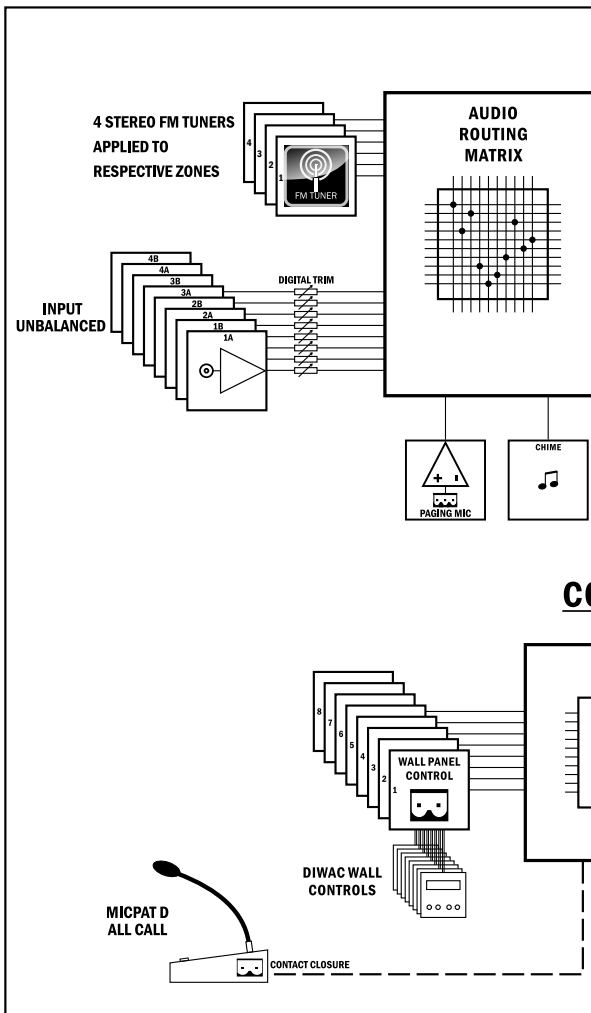

AUDIO

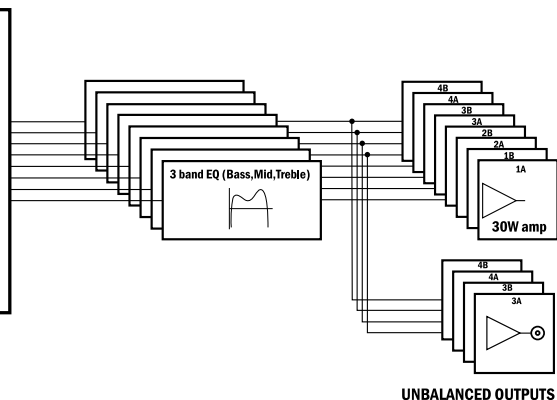

CONTROL

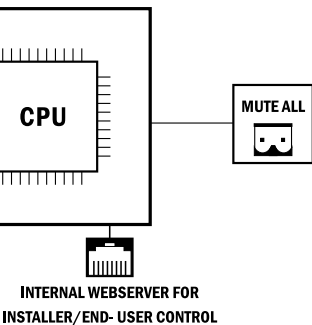

Connecting the paging microphone

As paging microphone for the AUDIOSYSTEM8.8 you can use any microphone and contact input. Apart provides the MICPAT D as a solution. To make the paging microphone compatible with the AUDIOSYSTEM8.8, cut the wires from the Micpat-D Din-5 connector and connect them to a 5-way Euroblock connector. The picture below shows how to connect the wires of the Micpat-D to the respective Euroblock connector.

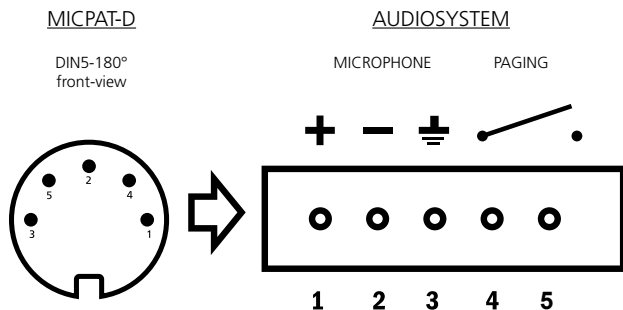

Wire colors :

- | | |
|--------------|-----------|
| 1. White | 4. Yellow |
| 2. Red | 5. Black |
| 3. Mass wire | |

Connections

Front panel



1. **Output status:** These leds indicate the status of the output zones. When a zone is active the corresponding led will be lit. The leds also indicate the status of the amplifiers, when an amplifier is short circuited, the output led will start to blink.
2. **Power led:** lights up when mains power is present and the unit has been switched on.
3. **Removable rack ears left and right.**

Rear panel

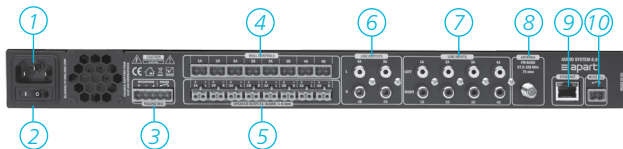

1. **Power inlet:** Connect the power cord here.
2. **Power switch:** Power the unit on and off.
3. **Paging mic:** Connection to MICPAT-D. A microphone balanced input is provided with a contact closure.
4. **The wall controls (DIWAC):** Only one control per connection is allowed, resulting in a maximum of 8 wall controls per AUDIOSYSTEM8.8. The DIWAC may not be daisy chained.
5. **Amplifiers:** There are 8 class D amplifiers in the AUDIOSYSTEM8.8. Speakers are connected with the female euroblocks. Each output is protected against short circuit, thermal overload and DC error.
6. **Line outputs:** These are copies of amplifier outputs 3A, 3B, 4A and 4B. Used for additional power amplifiers or 100V amplifiers.
7. **Line inputs:** The AUDIOSYSTEM8.8 has 8 audio line inputs, which can be configured as 4 stereo inputs or 8 mono inputs.

8. **FM antenna:** Connect the FM antenna wire here. When you want to connect the input to an antenna or cable distribution network, you need to connect through a galvanic separation transformer designed for FM signals. We advise you to always use a separation transformer to connect to a cable distribution network because otherwise it may lead to unpredictable behavior and even system damage.
9. **Network cable connector:** connect to a network, AUDIOSYSTEM8.8 supports DHCP and DNS. A connection with the device can be established through any web browser.
10. **Emergency / Mute all:** Contact closure for emergency mute on all zones.

Network

Connect a standard RJ45 cable from your network router to the unit. Make sure that the DHCP function of your AUDIOSYSTEM8.8 is enabled. Make sure you're pc is connected to the same network.

Connect to device:

- Open your web browser and open the link "<http://system88/config.html>". This link will open the configuration GUI of the AUDIOSYSTEM8.8.
- The graphical user interface may be accessed by <http://system88>.
- When the device is powered on, the wall control will show the device's IP address.

Specifications

Unbalanced inputs 1 - 8	
Input impedance:	10 kohm
Sensitivity:	940 mVrms
Max input voltage:	3.5 Vrms
Input range	-33 dB / +12 dB
Amp Outputs 1- 8	
Minimum load	6 ohm
Max output level	+26 dBV
SNR	98 dB @ 1 % THD, 1 kHz
THD-N full power -6 dB @ 1 kHz	0.061%
Noise floor	-74 dBV
Noise floor muted:	-119 dBV
Line outputs 5 - 8	
Output impedance	330 ohm
Max output level	10 dBV

SNR	90 dB @ 1 % THD, 1 kHz
Noise floor	-83 dBV
THD-N	0.0031% @ max input -6 dB, 1 kHz
Channel separation	
Line input to amplifier output ch 1A - ch1B	84 dB @ 1kHz, 65 dB @ 20 kHz @ Full power with 8 ohm load
Line input to line output ch 3A - ch 3B	83 dB @1 kHz, 77 dB @ 20 kHz @ Full power
EQ	
Bass range:	100 Hz / min -12 dB & max: +12 dB
Mid range:	1 kHz / min -12 dB & max: +12 dB
Treble range:	10 kHz / min -12 dB & max: +12 dB
Paging mic	
Sensitivity	32.33 mVrms
SNR	87.6 dB @ 1% THD (to amplifier)
Noise floor	-63.2 dBV
THD-N	0.1% @ full power -6 dB, 1 kHz, 8 ohm

FM	
Frequency spacing	100 kHz
Frequency range	87.5 MHz – 108.0 MHz
Power supply	
Power supply	SMPS
Input voltage range	85 – 264 VAC
Max power	150 W
Wall controls	
Voltage output	24 V
Power consumption	110 mA, automatic fused
Communication	2 wire interface
Dimensions and weight	
W x D x H	484 x 316 x 44 mm
Net Weight	4 kg
Amp Topology	
Type	Class-D

developed
by
Audioprof nv
Industriepark Brechtsebaan 8 bus 1
2900 Schoten - Belgium

Company names, product names and trademarks are property of their respective owners.

Apart-Audio specifications are subject to change without notice.

