



AUDIOSYSTEM8.8 Control command list

AUDIOSYSTEM8.8 CONTROL COMMAND LIST

1.	CONFIGURE THE COMMUNICATION	2
2.	COMMAND STRUCTURE.....	4
3.	COMMAND LIST	5
3.1	VOLUME	5
3.2	INPUT LIST	5
3.3	INPUT SELECTION	6
3.4	MUTE STATUS	7
3.5	BASS	8
3.6	MID.....	9
3.7	TREBLE.....	10
3.8	BALANCE	11
3.9	ZONE NAME	11
3.10	DEFAULT STATUS.....	12
3.11	PARTY MODE.....	13
3.12	ZONE CONFIGURATION	14
3.13	ZONE SETTINGS	15

1. CONFIGURE THE COMMUNICATION

➤ Retrieve the IP-address

1. Connect the AUDIOSYSTEM8.8 with the network
2. Connect a DIWAC to the unit.
3. Toggle the power on/off
4. After startup, the DIWAC will show the IP-address of the AUDIOSYSTEM8.8 in the current network.

➤ Send a command to the AUDIOSYSTEM8.8

- a. Use TCP/IP program such as HERCULES
 1. Open "TCP CLIENT"
 2. Add the AUDIOSYSTEM8.8 IP-address
 3. Add the port number 80
 4. Press connect

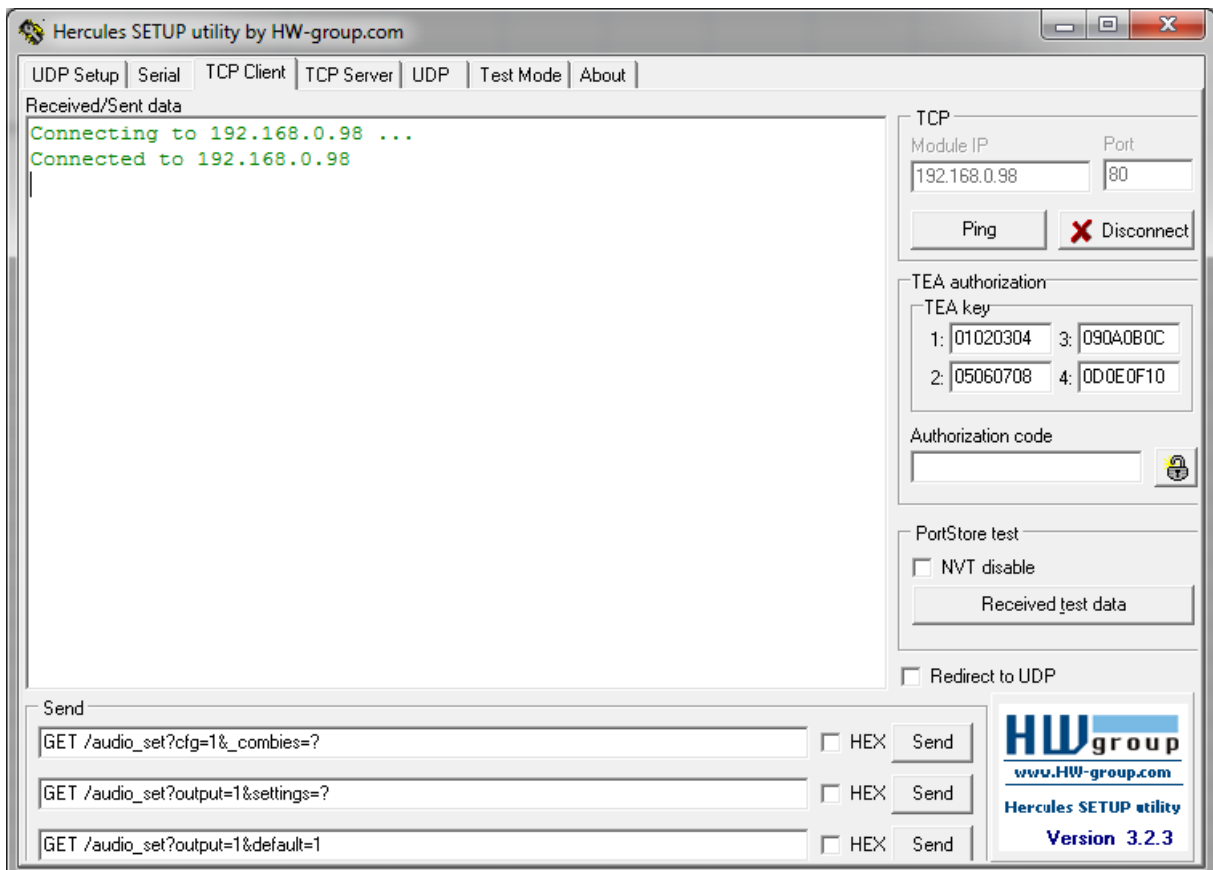

- b. Use a standard web browser

The webserver communication is platform independent. It is possible to control AUDIOSYSTEM8.8 with every web browser.

1. Open a web browser → Example: Firefox
2. URL → "IP-address" / "command"
For example: `192.168.0.98/audio_set?output=1&volume=?`
(this returns the volume of output 10)

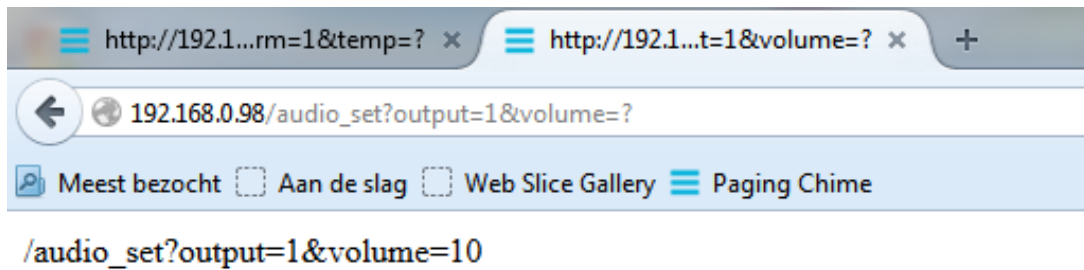

2. COMMAND STRUCTURE

Every command has to start with "audio_set?/".

You find the structure of the commands in the following table.

Command*		Min	Max	Remarks	
audio_set?	output=x &	volume=	0	50	
		vchan=	1	# channels	
		channel=	# input		
		chn_list			
		muted=	0	1	
		bass=	-12	12	
		mid=	-12	12	
		treble=	-12	12	
		balance=	-30	30	
		name=	(new name)		
		default=	0	1	
		settings=			
	combi = 1	active=	0	1	
	cfg=1	_out_stereo=			
		_outputs=			

*For further reference of these commands please go to section 3

For example:

The command to set the bass level of output 3 to 4: "audio_set?output=3&bass=4"

The command to get the bass level of output 3: "audio_set?output=3&bass=?"

3. COMMAND LIST

3.1 VOLUME

GET VOLUME

COMMAND: GET /audio_set?output=1&volume=?

```
Connecting to 192.168.0.98 ...
Connected to 192.168.0.98
GET /audio_set?output=1&volume=?HTTP/1.1 200 OK
Content-Type: text/html
Connection: keep-alive
Cache-Control: no-cache
Content-Length: 33

/audio_set?output=1&volume=17
```

SET VOLUME

COMMAND: GET /audio_set?output=1&volume=5

<u>VALUE</u>	<u>STATUS</u>
0	Mute
1 - 50	Volume

```
|
GET /audio_set?output=1&volume=5HTTP/1.1 200 OK
Content-Type: text/html
Connection: keep-alive
Cache-Control: no-cache
Content-Length: 32

/audio_set?output=1&volume=5
```

3.2 INPUT LIST

GET INPUT LIST

COMMAND : GET /audio_set?output=3&chn_list=?

```
GET /audio_set?output=3&chn_list=?HTTP/1.1 200 OK
Content-Type: text/html
Connection: keep-alive
Cache-Control: no-cache
Content-Length: 198

/audio_set?output=3&chn_list=[{"name":"Line%201","channel":1,"freq":0}, {"name":"Line%
202","channel":3,"freq":0}, {"name":"Line%203","channel":5,"freq":0}, {"name":"Line%
204","channel":7,"freq":0}]
```

3.3 INPUT SELECTION

GET INPUT SELECTION

COMMAND: GET /audio_set?output=1&vchan=?

```
GET /audio_set?output=1&vchan=?HTTP/1.1 200 OK
Content-Type: text/html
Connection: keep-alive
Cache-Control: no-cache
Content-Length: 31

/audio_set?output=1&vchan=4
```

SET INPUT SELECTION

COMMAND: GET /audio_set?output=1&vchan=2

<u>Min</u>	<u>Max</u>
1	# channels

```
GET /audio_set?output=1&vchan=2HTTP/1.1 200 OK
Content-Type: text/html
Connection: keep-alive
Cache-Control: no-cache
Content-Length: 31

/audio_set?output=1&vchan=2
```

3.4 MUTE STATUS

GET MUTE

COMMAND: GET /audio_set?output=1&muted=?

```
GET /audio_set?output=1&muted=?HTTP/1.1 200 OK
Content-Type: text/html
Connection: keep-alive
Cache-Control: no-cache
Content-Length: 31
```

```
/audio_set?output=1&muted=0
```

SET MUTE

COMMAND : GET /audio_set?output=1&muted=1

```
GET /audio_set?output=1&muted=1HTTP/1.1
Content-Type: text/html
Connection: keep-alive
Cache-Control: no-cache
Content-Length: 31
```

VALUE	STATUS
0	Unmute
1	Mute

```
/audio_set?output=1&muted=1
```

3.5 **BASS**

GET BASS

COMMAND : GET /audio_set?output=1&bass=?

```
GET /audio_set?output=1&bass=?HTTP/1.1 200 OK
Content-Type: text/html
Connection: keep-alive
Cache-Control: no-cache
Content-Length: 30
```

/audio_set?output=1&bass=0

SET BASS

COMMAND : GET /audio_set?output=1&bass=5

	bass
VALUE	0 to 24

```
GET /audio_set?output=1&bass=5HTTP/1.1 200 OK
Content-Type: text/html
Connection: keep-alive
Cache-Control: no-cache
Content-Length: 30
```

/audio_set?output=1&bass=5

3.6 MID

GET MID

COMMAND: GET /audio_set?output=1&mid=?

```
GET /audio_set?output=1&mid=?HTTP/1.1 200 OK
Content-Type: text/html
Connection: keep-alive
Cache-Control: no-cache
Content-Length: 29
```

```
/audio_set?output=1&mid=5
```

SET MID

COMMAND: GET /audio_set?output=1&mid=5

	<u>mid</u>
VALUE	0 to 24

```
GET /audio_set?output=1&mid=5HTTP/1.1 200 OK
Content-Type: text/html
Connection: keep-alive
Cache-Control: no-cache
Content-Length: 29
```

```
/audio_set?output=1&mid=5
```

3.7 TREBLE

GET TREBLE

COMMAND = GET /audio_set?output=1&treble=?

```
GET /audio_set?output=1&treble=?HTTP/1.1 200 OK
Content-Type: text/html
Connection: keep-alive
Cache-Control: no-cache
Content-Length: 32
```

```
/audio_set?output=1&treble=0
```

SET TREBLE

COMMAND: GET /audio_set?output=1&treble=5

	<u>treble</u>
VALUE	0 to 24

```
GET /audio_set?output=1&treble=5HTTP/1.1
Content-Type: text/html
Connection: keep-alive
Cache-Control: no-cache
Content-Length: 32
```

```
/audio_set?output=1&treble=5
```

3.8 BALANCE

GET BALANCE

COMMAND: GET /audio_set?output=1&balance=?

```
GET /audio_set?output=1&balance=?HTTP/1.1 200 OK
Content-Type: text/html
Connection: keep-alive
Cache-Control: no-cache
Content-Length: 33
```

```
/audio_set?output=1&balance=0
```

SET BALANCE

COMMAND: GET /audio_set?output=1&balance=5

	balance
VALUE	0 to 60

```
GET /audio_set?output=1&balance=5HTTP/1.1 200 OK
Content-Type: text/html
Connection: keep-alive
Cache-Control: no-cache
Content-Length: 33
```

```
/audio_set?output=1&balance=5
```

3.9 ZONE NAME

GET ZONE NAME

COMMAND: GET /audio_set?output=1&name=?

```
GET /audio_set?output=1&name=?HTTP/1.1 200 OK
Content-Type: text/html
Connection: keep-alive
Cache-Control: no-cache
Content-Length: 39
```

```
/audio_set?output=1&name="Zone%20"
```

Note: Name: "Zone%20"

An empty space is represented by %20, this is the hexadecimal value of the ASCII character "SPACE"

3.10 DEFAULT STATUS

SET DEFAULT STATUS

COMMAND: GET /audio_set?output=1&default=1

```
GET /audio_set?output=1&default=1 HTTP/1.1 200 OK
Content-Type: text/html
Connection: keep-alive
Cache-Control: no-cache
Content-Length: 33
```

```
/audio_set?output=1&default=1
```

Note: Which settings go to default when set.

- Volume
- Input selection
- Bass
- Mid
- Treble
- Balance

3.11 PARTY MODE

GET PARTY MODE STATUS

COMMAND: GET /audio_set?combi=1&active=?

```
GET /audio_set?combi=1&active=?HTTP/1.1 200 OK
Content-Type: text/html
Connection: keep-alive
Cache-Control: no-cache
Content-Length: 31
```

```
/audio_set?combi=1&active=0
```

SET PARTY MODE STATUS

The status can be set to two values

<u>VALUE</u>	<u>STATUS</u>
0	Disable
1	Enable

COMMAND: GET /audio_set?combi=1&active=1

```
GET /audio_set?combi=1&active=1HTTP/1.1 200 OK
Content-Type: text/html
Connection: keep-alive
Cache-Control: no-cache
Content-Length: 31
```

```
/audio_set?combi=1&active=1
```

3.12 **ZONE CONFIGURATION**

GET ZONE CONFIGURATION

COMMAND: GET /audio_set?cfg=1&_out_stereo=?

```
GET /audio_set?cfg=1&_out_stereo=?HTTP/1
Content-Type: text/html
Connection: keep-alive
Cache-Control: no-cache
Content-Length: 35
```

VALUE	STATUS
0	Mono
1	Stereo

```
/audio_set?cfg=1&_out_stereo=14
```

The unit will respond with a decimal value which represents a bitmask.

For example:

14 (decimal value) = 1110 (binary)

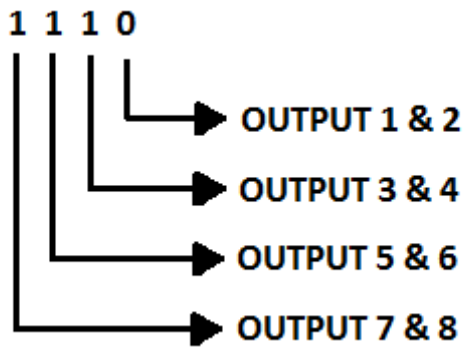

Zone 1: Output 1

Zone 2: Output 2

Zone 3: Output 3 & 4

Zone 4: Output 5 & 6

Zone 5: Output 7 & 8

3.13 **ZONE SETTINGS**
GET SETTINGS

COMMAND: GET /audio_set?output=1&settings=?

```

GET /audio_set?output=1&settings=?HTTP/1.1 200 OK
Content-Type: text/html
Connection: keep-alive
Cache-Control: no-cache
Content-Length: 202

/audio_set?output=1&settings=
{"name":"Test","channel":5,"vchan":2,"volume":10,"muted":0,"balance":30,"min":35,
"max":36,"bass":12,"mid":12,"treble":12,"amp":1,"page_chn":0,"page_ofs":10,"combi
_nr":0}
  
```

The reply contains the following information:

- Name → Zone name
- Channel → Physical selected input 1 - 8
- Vchan → Selected input 1 - # inputs
- Volume → Volume level 0 - 50
- Muted → Status of the mute function 0 - 1
- Balance → Balance level 0 - 60
- Min → Minimum output level 0 - 50
- Max → Maximum output level 0 - 60
- Bass → Bass level 0 - 24
- Mid → Mid level 0 - 24
- Treble → Treble level 0 - 24
- Amp → Inactive / Active 0 - 1
- Page_chn → Paging Inactive / Active 0 - 1
- Page_ofs → Paging output level 0 - 50
- Combi_nr → Party mode Inactive / Active 0 - 1

developed
by
Audioprof nv
Industriepark Brechtsebaan 8 bus 1
2900 Schoten - Belgium

Company names, product names and trademarks are property of their
respective owners.

Apart-Audio specifications are subject to change without notice.

