

# EKX Passive Loudspeakers

EKX-12, EKX-15, EKX-15S, and EKX-18S

en | User Manual

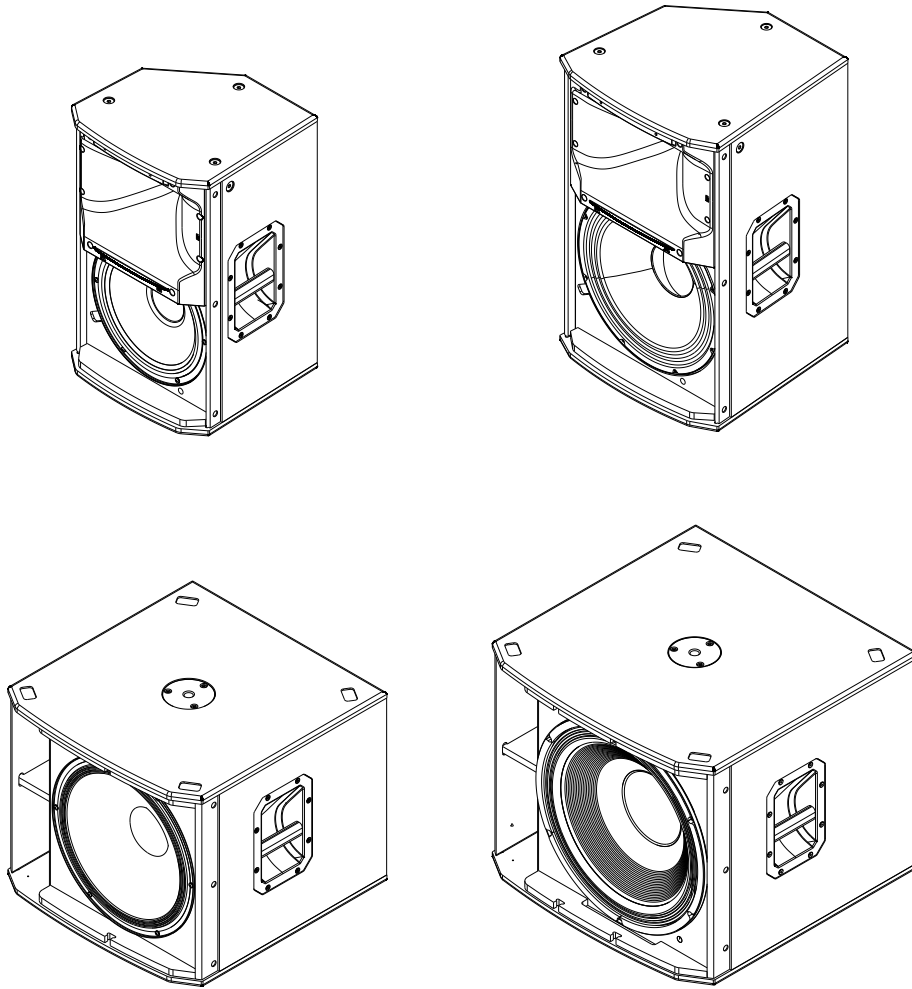



---

## Table of contents

<b>1</b>	<b>Safety</b>	<b>4</b>
1.1	Important Safety Instructions	4
1.2	Suspension	4
1.3	Precautions	5
1.4	Notices	5
<b>2</b>	<b>Description</b>	<b>6</b>
2.1	System features	7
<b>3</b>	<b>System overview</b>	<b>8</b>
3.1	Dimensions	8
3.2	Frequency response	9
<b>4</b>	<b>Tripod and floor monitor operation</b>	<b>11</b>
4.1	Tripod or pole mount	11
4.2	Floor monitor	13
<b>5</b>	<b>Suspension</b>	<b>14</b>
<b>6</b>	<b>Recommended configurations</b>	<b>18</b>
6.1	Basic stereo system using full-range systems	18
6.2	Using full-range systems as stage monitors	19
6.3	Stacking full-range-systems with subwoofers	20
<b>7</b>	<b>Troubleshooting</b>	<b>21</b>
<b>8</b>	<b>Technical data</b>	<b>22</b>

## 1 Safety

### 1.1 Important Safety Instructions

1. Read these instructions.
2. Keep these instructions.
3. Heed all warnings.
4. Follow all instructions.
5. Clean only with a dry cloth.
6. Do not install near any heat sources such as radiators, heat registers, stoves, or other apparatus (including amplifiers) that produce heat.

### 1.2 Suspension

---



#### **Warning!**

Suspending any object is potentially dangerous and should only be attempted by individuals who have a thorough knowledge of the techniques and regulations of suspending objects overhead. Electro-Voice strongly recommends all loudspeakers be suspended taking into account all current national, federal, state, and local laws and regulations. It is the responsibility of the installer to ensure all loudspeakers are safely installed in accordance with all such requirements. When loudspeakers are suspended, Electro-Voice strongly recommends the system be inspected at least once per year or as laws and regulations require. If any sign of weakness or damage is detected, remedial action should be taken immediately. The user is responsible for making sure the wall, ceiling, or structure is capable of supporting all objects suspended overhead. Any hardware used to suspend a loudspeaker not associated with Electro-Voice is the responsibility of others.

---





#### **Warning!**

Do not suspend this product in any other manner than explicitly described in this manual, or Electro-Voice installation guides. Suspending any object (loudspeaker) is potentially dangerous and should only be done by individuals with thorough knowledge of techniques, materials, and regulations for suspending objects overhead. Electro-Voice loudspeakers can only be suspended using accessories and hardware described in Electro-Voice manuals and installation guides. **Do NOT use handles to suspend the loudspeaker. Handles on Electro-Voice loudspeakers are intended to only be used for temporary transport by people. Items, such as fiber rope, wire rope, cables, or other types of materials cannot be used to suspend loudspeaker from the handles.** Any hardware used to suspend a loudspeaker not associated with Electro-Voice is the responsibility of others.

---

## 1.3

### Precautions

	Do not use Electro-Voice loudspeakers in an environment where temperatures are below 0°C (32°F) or exceed +40°C (104°F).
	Never expose an Electro-Voice loudspeaker to rain, water, or high moisture.
	Electro-Voice loudspeakers are easily capable of generating sound pressure levels sufficient to cause permanent hearing damage to anyone within normal coverage distance. Caution should be taken to avoid prolonged exposure to sound pressure levels exceeding 90 dB.

## 1.4

### Notices

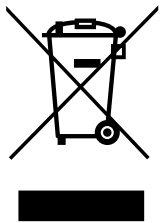

#### Old electrical and electronic appliances

Electrical or electronic devices that are no longer serviceable must be collected separately and sent for environmentally compatible recycling (in accordance with the European Waste Electrical and Electronic Equipment Directive).

To dispose of old electrical or electronic devices, you should use the return and collection systems put in place in the country concerned.

### 2

## Description

Thank you for choosing an Electro-Voice passive loudspeaker system. Please take time to consult the manual to understand all the features built into your EV system and fully utilize its performance capabilities.

The EKX series is the newest member of the Electro-Voice portable loudspeaker family, and combines legendary EV sound quality and reliability with the latest technology – all in a compact package suitable for a wide range of sound reinforcement scenarios, including musicians/DJs and live/club/installed sound applications. The EKX series features eight (8) models (four (4) powered and four (4) passive), including 12-inch and 15-inch two-way models and 15-inch and 18-inch subwoofers.

EV-engineered components, Signal Synchronized Transducers (SST) waveguide design provides precise coverage and superior sound quality at high SPLs. award-winning industrial design – with robust wood enclosures and durable finish – ensures that EKX speakers look as great as they sound.

Passive EKX models deliver up to 134 dB SPL utilizing high-sensitivity transducers designed and engineered by EV (12-inch EVS-12M woofer / 15-inch EVS-15M woofer, each coupled with a DH-1M 1-inch titanium compression driver; 15-inch EVS-15C subwoofer / 18-inch EVS-18C subwoofer).

EKX passive models are ideal for portable and installed applications, with lightweight and compact 15-mm wood enclosures with internal bracing, durable finish, eight (8) M10 threaded mounting points (full-range only), aluminum pole-mounts, and all-metal handles.

## 2.1 System features

### **EKX-12 – 12-inch two-way passive loudspeaker system**

- 1400 W (Peak), 131 dB SPL utilizing high-sensitivity transducers designed and engineered by EV.
- EV-patented Signal Synchronized Transducers (SST) waveguide design provides precise and consistent coverage.
- Lightweight, compact 15-mm wood enclosure with internal bracing and durable finish.
- Eight (8) M10 threaded mounting points , aluminum pole-mounts, and all-metal handles.
- 90° x 60° pattern coverage for best coverage on mid-size stages and 40° monitor angle with rubber feet.

### **EKX-15– 15-inch two-way passive loudspeaker system**

- 1600 W (Peak), 132 dB SPL utilizing high-sensitivity transducers designed and engineered by EV.
- EV-patented Signal Synchronized Transducers (SST) waveguide design provides precise and consistent coverage.
- Lightweight, compact 15-mm wood enclosure with internal bracing and durable finish.
- Eight (8) M10 threaded mounting points , aluminum pole-mounts, and all-metal handles.
- 90° x 60° pattern coverage for best coverage on mid-size stages and 40° monitor angle with rubber feet.

### **EKX-15S – 15-inch passive subwoofer loudspeaker system**

- 1600 W (Peak), 133 dB SPL utilizing high-sensitivity transducers designed and engineered by EV.
- Lightweight, compact 15-mm wood enclosure with internal bracing and durable finish.
- Large slot ports for low distortion and excellent bass extension.
- Metal grille reinforcement bar.
- M20 threaded pole mount plate.

### **EKX-18S – 18-inch passive subwoofer loudspeaker system**

- 1600 W (Peak), 134 dB SPL utilizing high-sensitivity transducers designed and engineered by EV.
- Lightweight, compact 15-mm wood enclosure with internal bracing and durable finish.
- Large slot ports for low distortion and excellent bass extension.
- Two (2) metal grille reinforcement bars.
- M20 threaded pole mount plate.

### 3 System overview

#### 3.1 Dimensions

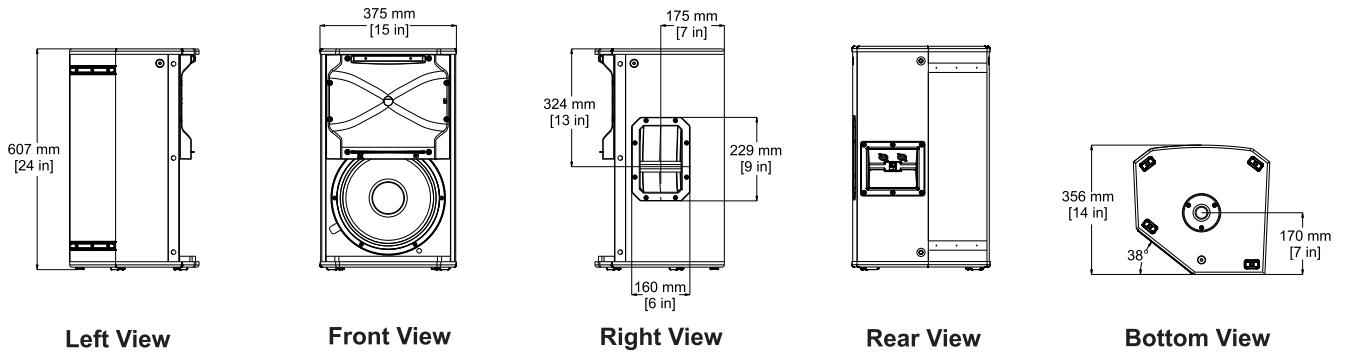

Figure 3.1: EKX-12 dimensions

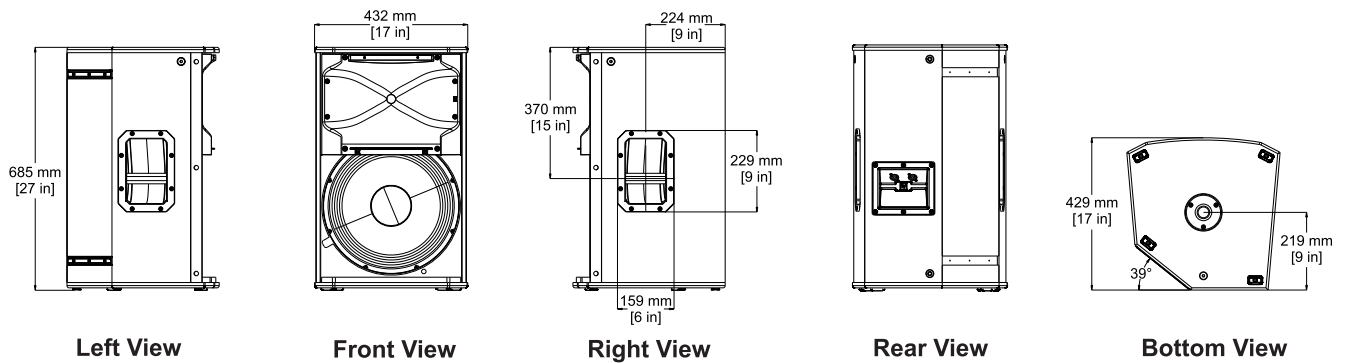

Figure 3.2: EKX-15 dimensions

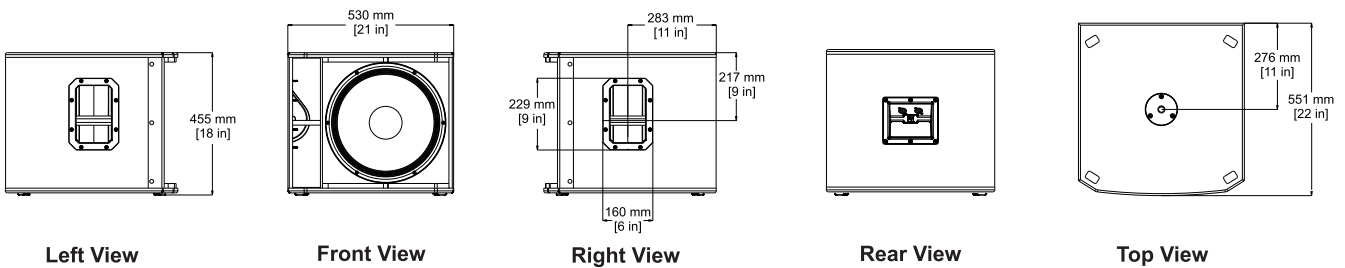

Figure 3.3: EKX-15S dimensions

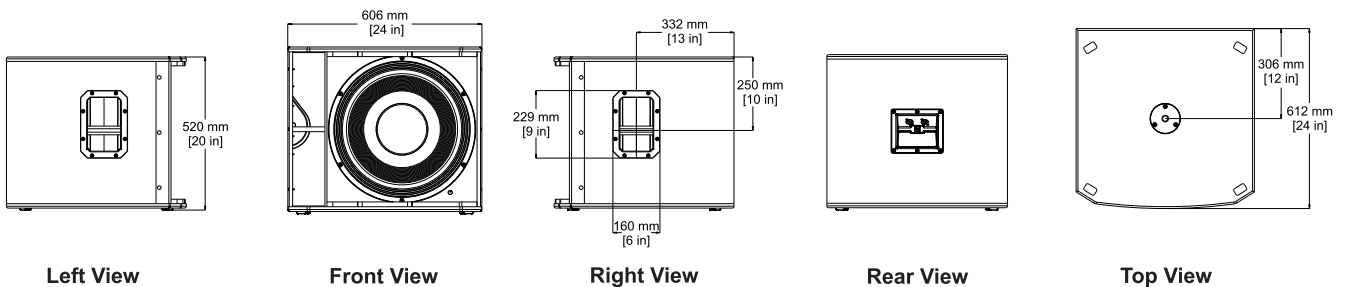

Figure 3.4: EKX-18S dimensions



## 3.2 Frequency response

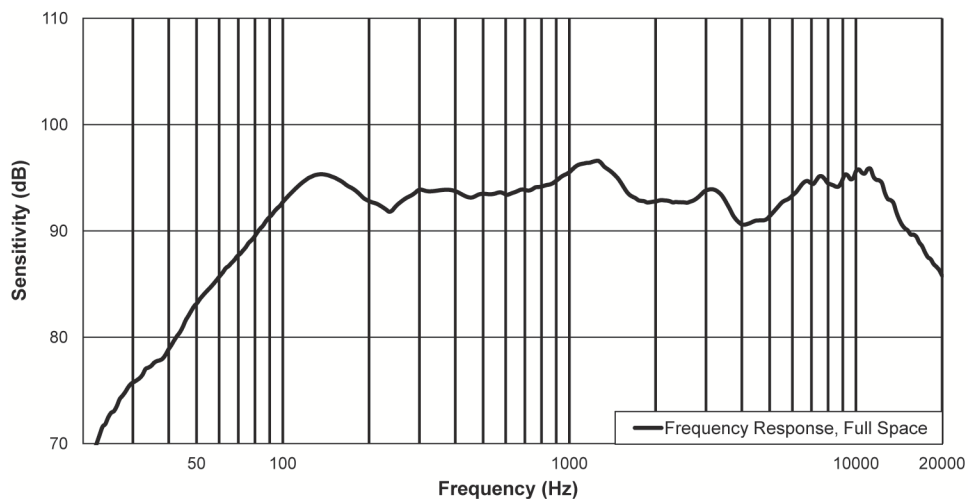

Figure 3.5: EKV-12 Frequency Response

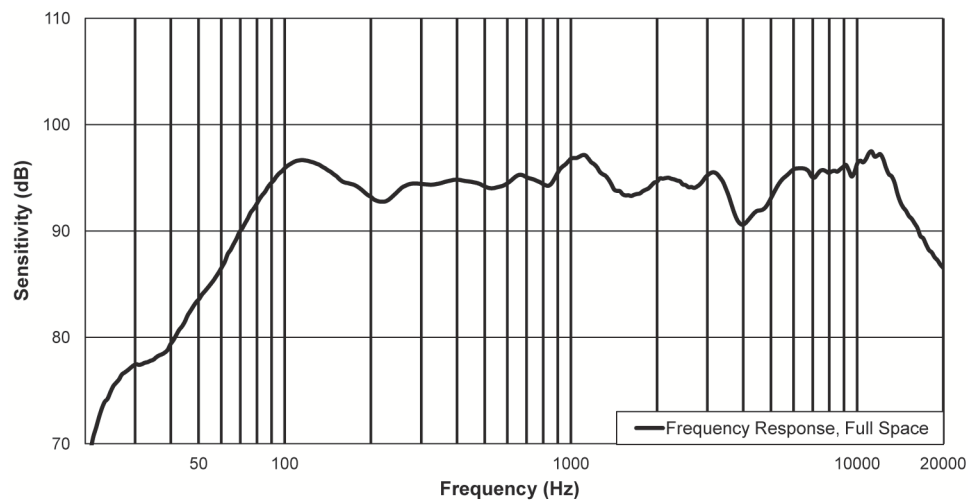
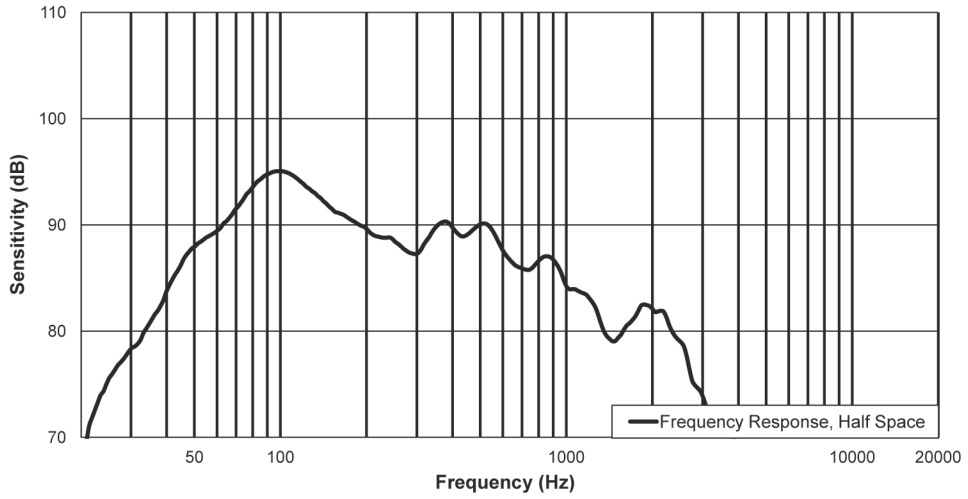
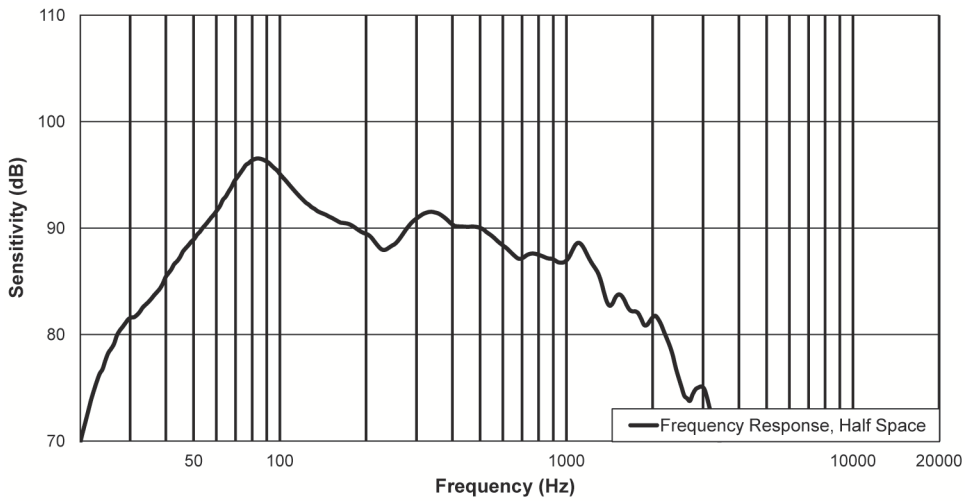

Figure 3.6: EKV-15 Frequency Response

# EKX Passive Loudspeakers



**Figure 3.7: EKX-15S Frequency Response**



**Figure 3.8: EKX-18S Frequency Response**

## 4 Tripod and floor monitor operation

### 4.1 Tripod or pole mount

EKX-12 and EKX-15 loudspeakers mount on a tripod stand or on a pole above a subwoofer.

#### Mounting a loudspeaker on a tripod stand

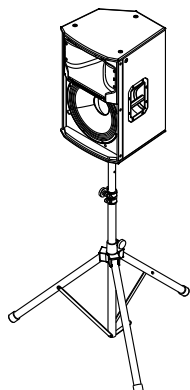

Figure 4.1: Full-Range model on a tripod stand



#### Caution!

Tripod is not evaluated for safety with this loudspeaker. Check the specifications of the tripod stand to be certain it is capable of supporting the weight of the loudspeaker.



#### Caution!

Two (2) person lift and placement is recommended for the heavier loudspeakers. Single person lift and placement of heavier loudspeakers could cause injury.

To **mount a loudspeaker on a tripod stand**, do the following:

1. Place the **tripod stand** on a level stable surface.
  - Fully extend the legs on the tripod stand.
  - Do not compromise the tripod stands structural integrity by trying to make the stand taller.
  - Do not attempt to suspend more than one (1) loudspeaker on a stand designed for a single loudspeaker.
2. Using two (2) hands lift the **loudspeaker**.
3. Set the **pole cup** located on the bottom of the loudspeaker onto the pole.

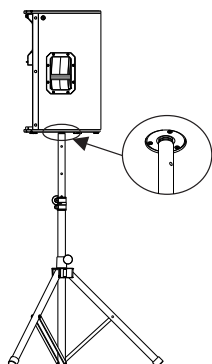

## Mounting a loudspeaker on a pole

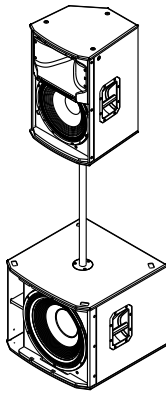

Figure 4.2: Full-Range/subwoofer stack with pole mount



### Caution!

Two (2) person lift and placement is recommended for the heavier loudspeakers. Single person lift and placement of heavier loudspeakers could cause injury.

To **mount a loudspeaker on a pole**, do the following:

1. Place the **subwoofer** on a level stable surface.
2. Insert the **M20 threaded pole** into the combo pole cup on the top of the subwoofer.

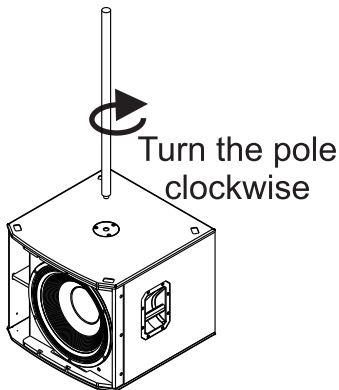

3. Turn the **M20 threaded pole** clockwise to secure the pole to the subwoofer.
4. Using two (2) hands lift the **loudspeaker**.
5. Set the **pole cup** located on the bottom of the loudspeaker onto the pole.

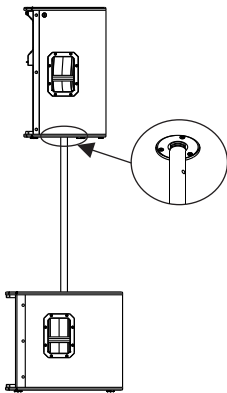

## 4.2 Floor monitor

EKX-12 and EKX-15 loudspeakers may be used as a floor monitor by placing the loudspeaker on the integral monitor angle.

To **set up a loudspeaker as a floor monitor**, do the following:

1. Place the **loudspeaker** on a level stable surface.
2. Safely route **cables** to prevent injury to performers, production crew, and audience members.



### Notice!

Secure cables with wire ties or tape whenever possible.

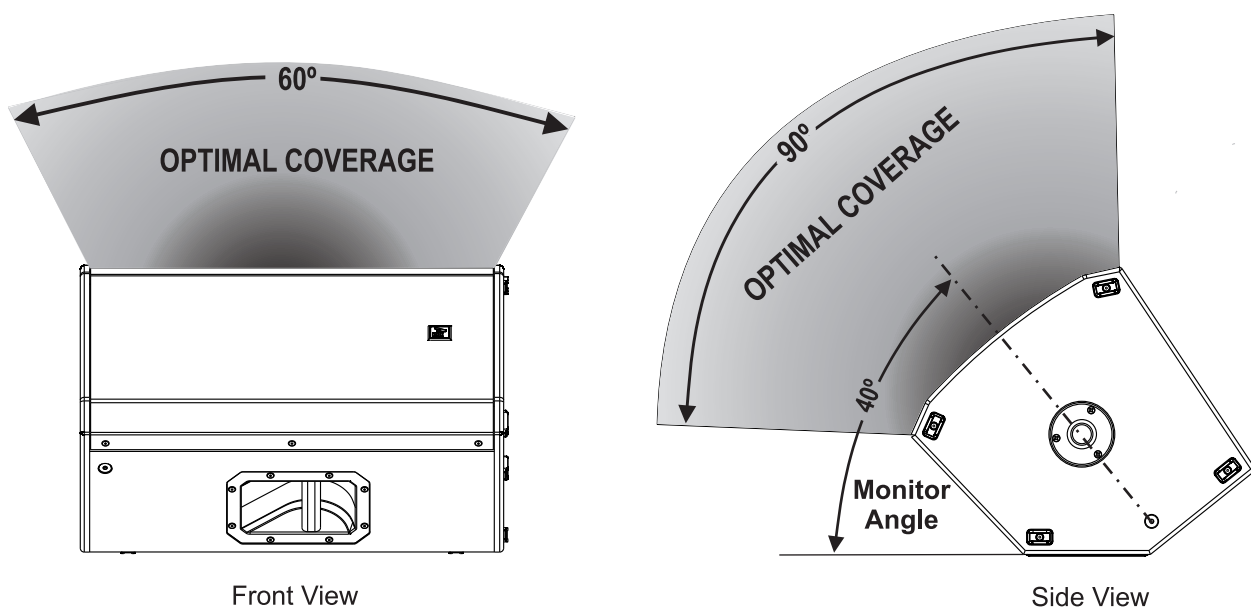

## 5 Suspension

The EKX-12 and EKX-15 enclosures have eight (8) M10 threaded points; six (6) points on top of the enclosure and two (2) points on the bottom. Forged shoulder eyebolts rated for overhead suspension may be used to suspend an individual loudspeaker, such as the EBK-M10 accessory.



### Warning!

Suspending any object is potentially dangerous and should only be attempted by individuals who have a thorough knowledge of the techniques and regulations of suspending objects overhead. Electro-Voice strongly recommends all loudspeakers be suspended taking into account all current national, federal, state, and local laws and regulations. It is the responsibility of the installer to ensure all loudspeakers are safely installed in accordance with all such requirements. When loudspeakers are suspended, Electro-Voice strongly recommends the system be inspected at least once per year or as laws and regulations require. If any sign of weakness or damage is detected, remedial action should be taken immediately. The user is responsible for making sure the wall, ceiling, or structure is capable of supporting all objects suspended overhead. Any hardware used to suspend a loudspeaker not associated with Electro-Voice is the responsibility of others.

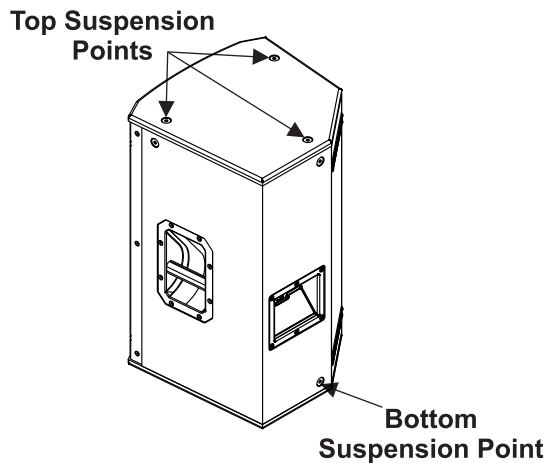

**Figure 5.1: Suspension points**

Prior to use, inspect the suspension points and associated hardware for any cracks, deformations, broken welds, corrosion, missing or damaged components which could reduce the suspension points strength. Replace any damaged hardware. Never exceed the limitations or maximum recommended load intended for the suspension points. As an added safety measure, it is suggested the user install an extra suspension point back to the building structural supports. This redundant safety point should have as little slack as possible (less than one (1) inch is preferable). Prior to each use, inspect the loudspeaker enclosures for any cracks, deformations, missing or damaged components, which could reduce enclosure strength. Replace any loudspeaker systems damaged or missing hardware.

### Installing the eyebolts

To **install the eyebolts**, do the following:

1. Remove the **M10 screws** from the suspension points.

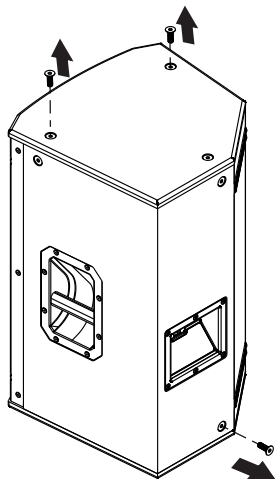

2. Replace the **M10 screw** with the fender washer and eyebolts.

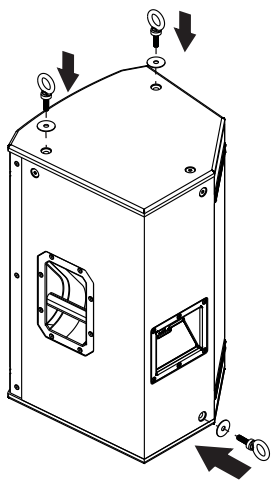

#### Notice!

If the eyebolts are removed reinstall the screws.

If the screws are not reinstalled air leaks occur in the enclosure, resulting in undesirable performance.

# EKX Passive Loudspeakers

---



## Warning!

Eyebolts must be fully seated and oriented in the plane of pull. Always use fender washers at least 1.5 inch in diameter and 1/16 inch thick under the eyebolt to distribute the load on the enclosure.

---

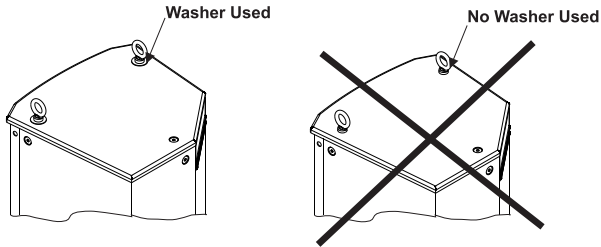

Figure 5.2: Eyebolt shown with and without washer

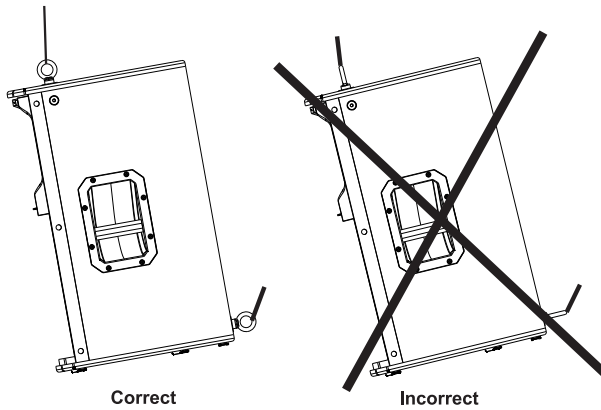

Figure 5.3: Eyebolts shown oriented in the plane of pull



50 lb per Suspension Point

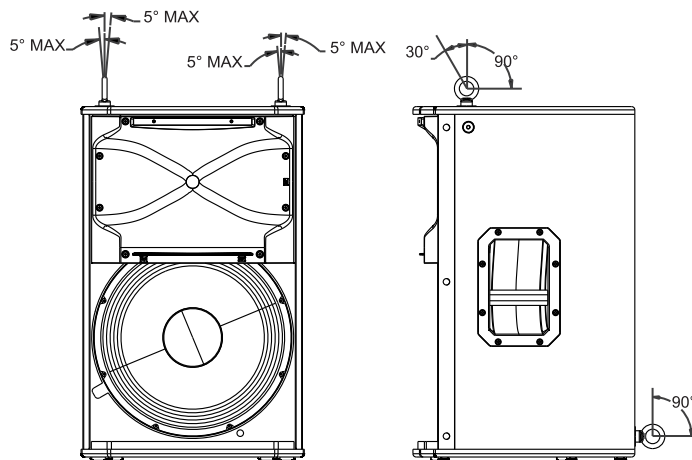

Figure 5.4: Maximum working load - vertical orientation



**Warning!**

Never suspend EKX Series loudspeakers in a vertical column array. Disregarding this warning could result in serious injury or death.

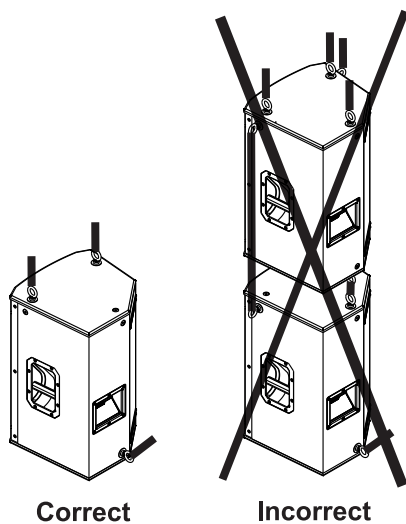
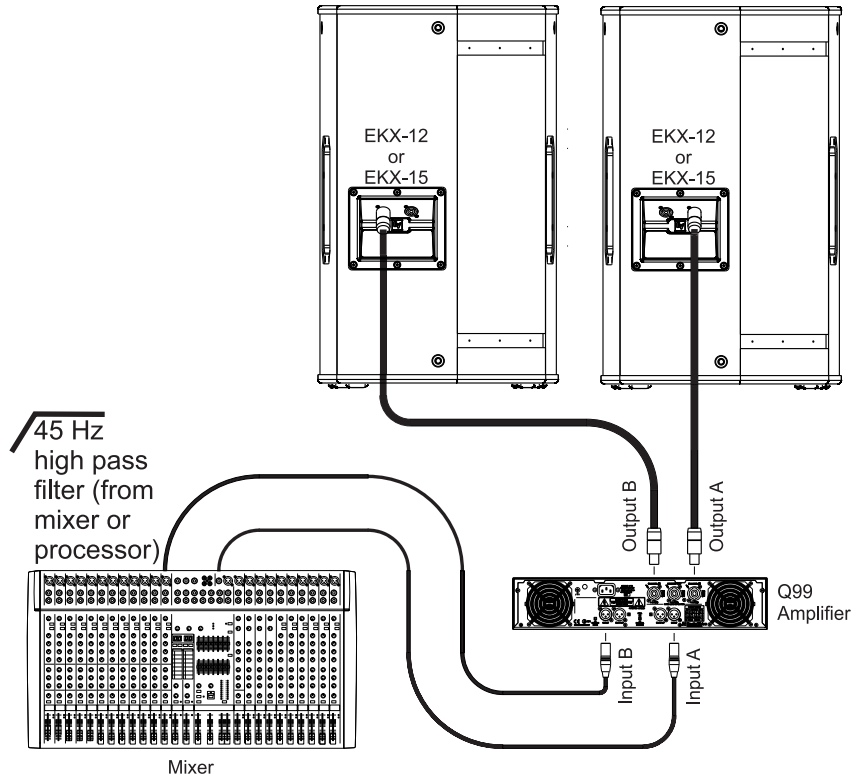

Figure 5.5: Loudspeaker vertical suspension

## 6 Recommended configurations

### 6.1 Basic stereo system using full-range systems

Basic stereo system using EKX-12's or EKX-15's (EKX-15 versions shown).



NL4 Pin Configuration	
Pin 1+ and 1-	Used
Pin 2+ and 2-	Not used



**Caution!**

Do not exceed the maximum load rating of the amplifier.

Amplifier Load (per Output Channel)		
# of Speakers	Nominal	Minimum
1	8 Ohms	7.2 Ohms
2	4 Ohms	3.6 Ohms
3	2.7 Ohms	2.4 Ohms
4	2 Ohms	1.8 Ohms

## 6.2 Using full-range systems as stage monitors

Multiple EKX-12's or EKX-15's in monitor position (EKX-15 versions shown).

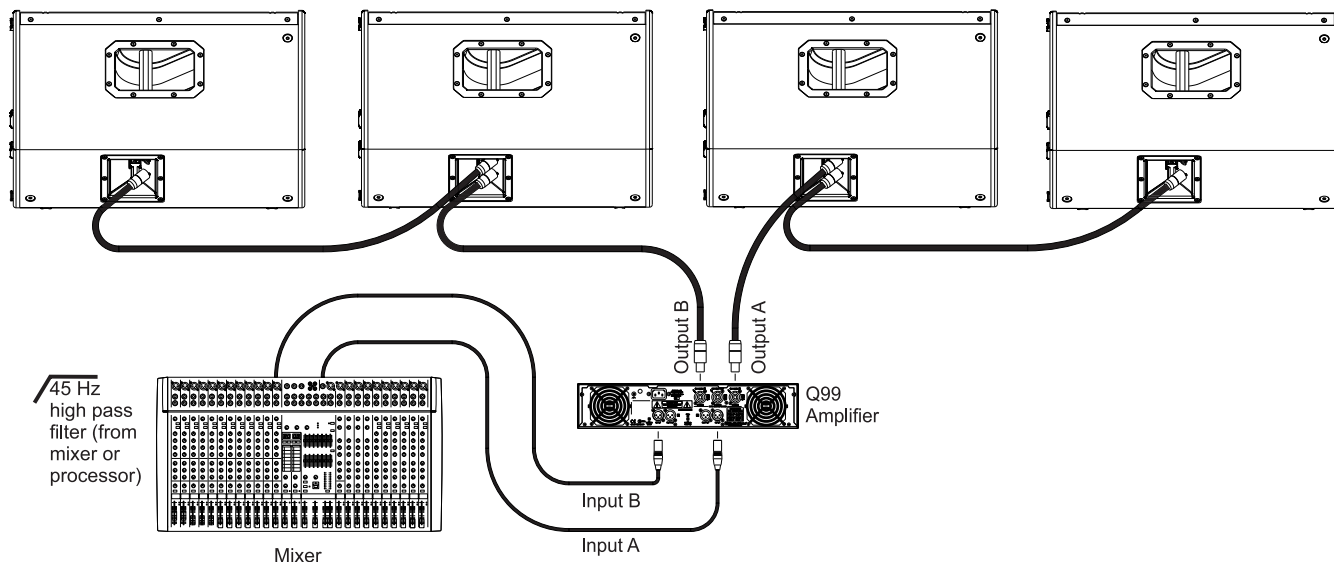

NL4 Pin Configuration	
Pin 1+ and 1-	Used
Pin 2+ and 2-	Not used



### Caution!

Do not exceed the maximum load rating of the amplifier.

Amplifier Load (per Output Channel)		
# of Speakers	Nominal	Minimum
1	8 Ohms	7.2 Ohms
2	4 Ohms	3.6 Ohms
3	2.7 Ohms	2.4 Ohms
4	2 Ohms	1.8 Ohms

## 6.3 Stacking full-range-systems with subwoofers

This configuration allows a user to increase the low frequency performance without using additional amplifier channels (EKX-15 and EKX-18S versions shown).

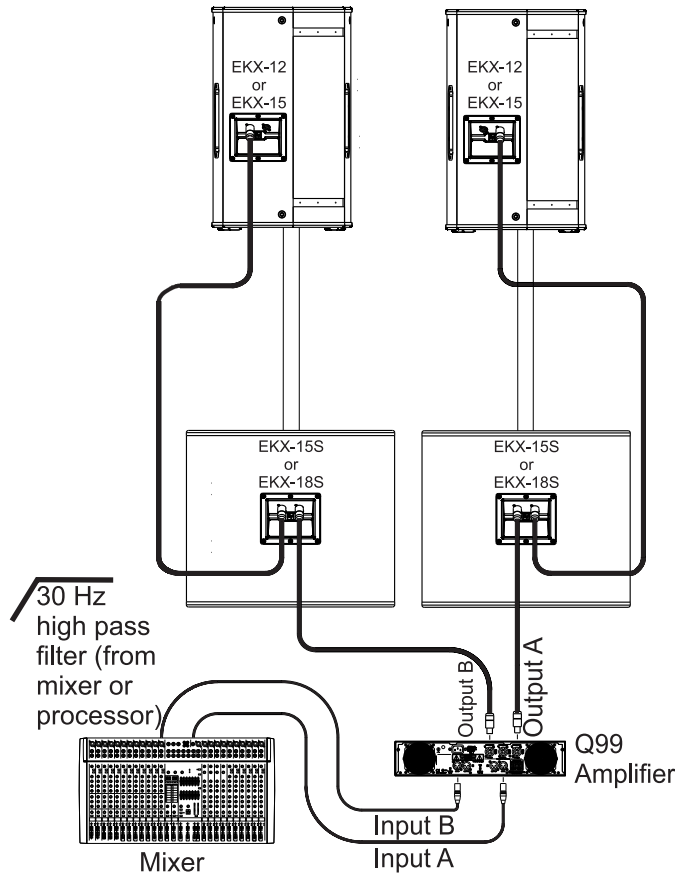

NL4 Pin Configuration	
Pin 1+ and 1-	Used
Pin 2+ and 2-	Not used



### Caution!

Do not exceed the maximum load rating of the amplifier.

Amplifier Load (per Output Channel)		
# of Subwoofer/Full-Range Combinations	Nominal	Minimum
1	4 Ohms	3.8 Ohms
2	2 Ohms	1.9 Ohms

## 7 Troubleshooting

Problem	Possible Cause(s)	Action
1. No sound	Amplifier	Connect a known working test loudspeaker to the amplifier outputs. If there is no sound, verify all the electronics are on, the signal routing is correct, the source is active; the volume is turned up, etc. Correct/repair/replace as necessary. If there is sound, the problem is in the wiring.
	Wiring	Verify you have connected the correct cables to the amplifier. Play something at a low level through the amplifier. Connect the test loudspeaker in parallel with the malfunctioning line. If the sound level is gone or is very weak, the line has a short in it (possibly a severe scrape, pinch, or a missed connection). Using the test loudspeaker, move down the line and test each connection/junction until you find the problem and correct it. Observe proper polarity.
2. Poor Low-Frequency Response	Loudspeakers wired out-of-polarity	When two (2) loudspeakers are connected out of polarity, the low frequencies will cancel each other acoustically. Carefully observe the wire markings or tracers on your loudspeaker wires. Verify the amplifier (+) terminal is connected to pin 1+ of the NL4 connector and the amplifier (-) terminal is connected to pin 1-of the NL4 connector.
3. Intermittent output such as cracking or distortion	Faulty connection	Check all connections at amplifier and loudspeakers to ensure they are all clean and tight. If the problem persists, check the wiring. See problem 1.
4. Constant noise such as buzzing, hissing or humming	Defective source or other electronic device	If noise is present, but no program material is playing, evaluate each component as necessary to isolate the problem. Most likely there is a break in the signal path.
	Poor system grounding or ground loop	Check and correct the system grounding, as required.
If these suggestions do not solve your problems, contact your nearest Electro-Voice dealer or Electro-Voice distributor.		

## 8 Technical data

EKX-12 and EKX-15

	<b>EKX-12</b>	<b>EKX-15</b>
Freq. Response (-3 dB):	82 Hz - 18 kHz <sup>1</sup>	75 Hz - 18 kHz <sup>1</sup>
Freq. Range (-10 dB):	55 Hz - 20 kHz <sup>1</sup>	50 Hz - 20 kHz <sup>1</sup>
Axial Sensitivity:	95 dB <sup>1</sup>	96 dB <sup>1</sup>
Maximum SPL:	131 dB Peak <sup>2</sup>	132 dB Peak <sup>2</sup>
Recommended High-Pass Freq.:	55 Hz	50 Hz
Coverage (H x V):	90° x 60°	
Power Handling:	350 W Continuous, 1400 W Peak	400 W Continuous, 1600 W Peak
LF Transducer:	EVS-12M 300 mm (12 in)	EVS-15M 381 mm (15 in)
HF Transducer:	DH-1M 1-inch titanium compression driver	
Crossover Freq.:	1.6 kHz	
Nominal Impedance:	8 Ohms	
Minimum Impedance:	7.5 Ohms	7.2 Ohms
Connectors:	Dual NL4	
Enclosure:	15 mm plywood with EVCoat	
Grille:	18 AWG steel with powdercoat	
Suspension:	(8) M10 threaded mounting points	
Dimensions (H x W x D):	607 mm x 375 mm x 356 mm (24 in x 15 in x 14 in)	685 mm x 432 mm x 429 mm (27 in x 17 in x 17 in)
Net Weight:	17.4 kg (38.3 lb)	23.2 kg (51.2 lb)
Shipping Weight:	21.4 kg (47.2 lb)	28.2 kg (62.2 lb)

1. Full Space Measurement.

2. Maximum SPL is measured at 1 m using broadband pink noise at rated peak power rating.

## EKX-15S and EKX-18S

	<b>EKX-15S</b>	<b>EKX-18S</b>
Freq. Response (-3 dB):	60 Hz - 100 Hz <sup>1</sup>	50 Hz - 100 Hz <sup>1</sup>
Freq. Range (-10 dB):	40 Hz - 300 Hz <sup>1</sup>	35 Hz - 300 Hz <sup>1</sup>
Axial Sensitivity:	95 dB <sup>1</sup>	96 dB <sup>1</sup>
Maximum SPL:	133 dB Peak <sup>2</sup>	134 dB Peak <sup>2</sup>
Recommended High-Pass Freq.:	35 Hz	30 Hz
Power Handling:	400 W Continuous, 1600 W Peak	
LF Transducer:	EVS-15C 381 mm (15 in)	EVS-18C 457 mm (18 in)
Nominal Impedance:	8 Ohms	
Minimum Impedance:	7.5 Ohms	7.0 Ohms
Connectors:	Dual NL4	
Enclosure:	15 mm plywood with EVCoat	
Grille:	18 AWG steel with powdercoat	
Dimensions (H x W x D):	455 in x 530 mm x 551 mm (18 in x 21 in x 22 in)	520 mm x 606 mm x 612 mm (20 in x 24 in x 24 in)
Net Weight:	24.9 kg (55.0 lb)	31.8 kg (70.0 lb)
Shipping Weight:d	31.3 kg (69.0 lb)	40.1 kg (88.4 lb)

1. Half Space Measurement.

2. Maximum SPL is measured at 1 m using broadband pink noise at rated peak power rating.

Bosch Sicherheitssysteme GmbH  
Robert-Bosch-Ring 5  
85630 Grasbrunn  
Germany  
[www.boschsecurity.com](http://www.boschsecurity.com)  
© Bosch Sicherheitssysteme GmbH, 2016

Bosch Security Systems, Inc  
12000 Portland Avenue South  
Burnsville MN 55337  
USA  
[www.electrovoice.com](http://www.electrovoice.com)

---

---

---