

I SERIES

BalancePoint™ Flyware

Accessory Guide

For Point Source and
Subwoofer loudspeakers
models IP8, IP6, IS8, and IS6

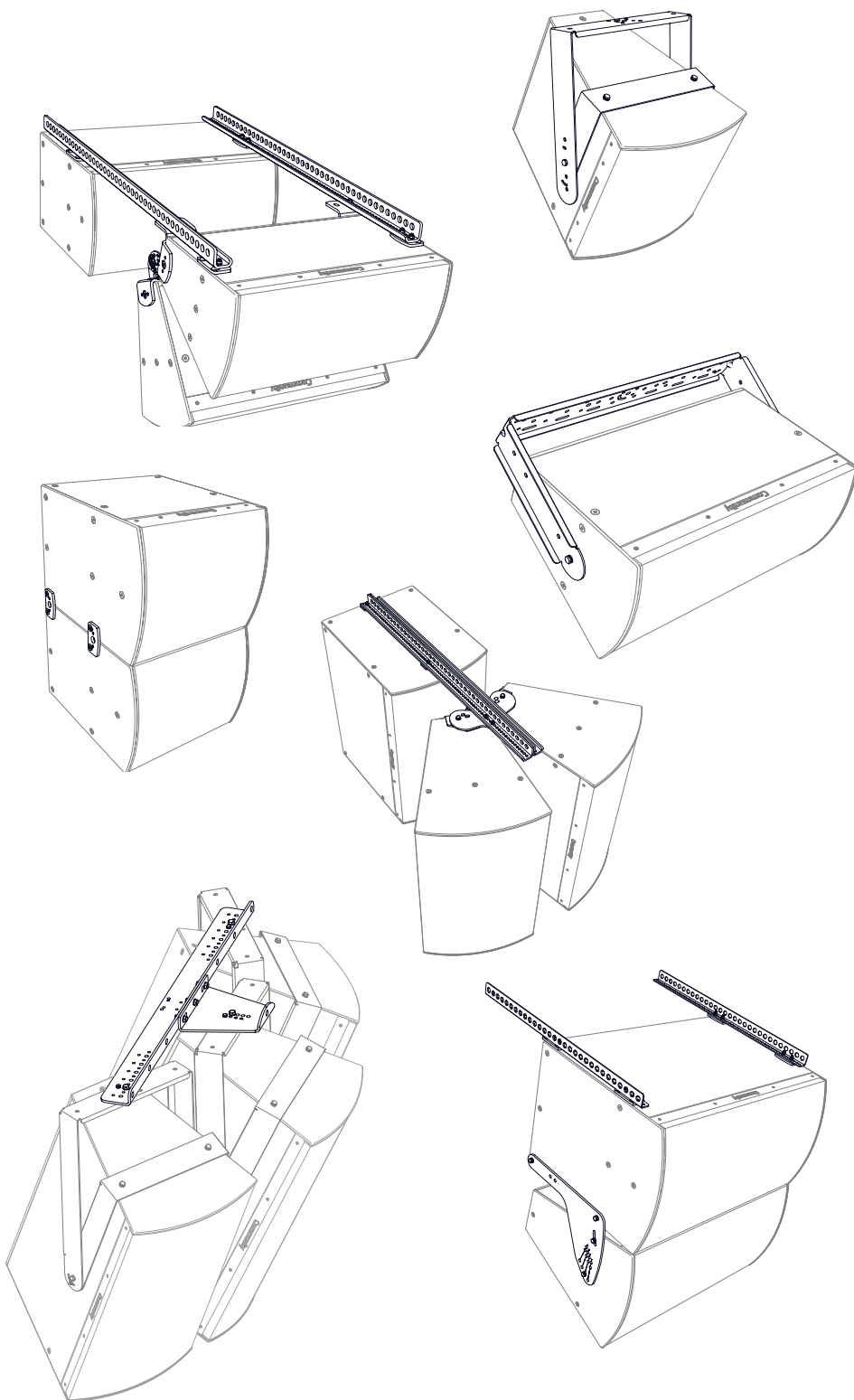

IMPORTANT SAFETY INSTRUCTIONS

Always follow these basic safety precautions when using or installing I SERIES loudspeakers and accessories:

- Read these instructions prior to assembly.
- Keep these instructions for reference.
- Heed all warnings.
- Follow all instructions, particularly those pertaining to rigging, mounting, hanging and electrical connections.
- Do not use this apparatus near water.
- Clean only with dry cloth.
- Do not block any ventilation openings. Install in accordance with the manufacturer's instruction.
- Do not install near any heat sources such as radiators, heat registers, stoves, light fixtures, or other apparatus (including amplifiers) that produce heat.
- Only use attachments and accessories that are specified and approved by the manufacturer.

Refer all servicing to qualified service personnel. Servicing is required when the apparatus has been damaged in any way, such as liquid has been spilled or objects have fallen into the apparatus, the apparatus has been exposed to rain or moisture, does not operate normally, or has been dropped.

The terms CAUTION, WARNING, and DANGER may be used in this manual to alert the reader to important safety considerations. If you have any questions or do not understand the meaning of these terms, do not proceed with installation. Contact your local dealer, distributor, or call Community directly for assistance. These terms are defined as:



CAUTION: describes an operating condition or user action that may expose the equipment or user to potential damage or danger.



WARNING: describes an operating condition or user action that will likely cause damage to the equipment or injury to the user or to others in the vicinity.



DANGER: describes an operating condition or user action that will immediately damage the equipment and/or be extremely dangerous or life threatening to the user or to others in the vicinity.

These installation instructions are for use by qualified personnel only. To reduce the risk of fire or electric shock do not perform any servicing other than that contained in the operating instructions unless you are qualified to do so.

UNPACKING / INSPECTION

Community I SERIES loudspeakers are engineered and manufactured to be rugged and they are carefully packed in sturdy cartons. However, it is recommended to thoroughly inspect each unit after it has been removed from the packaging, as damage could occur during shipping.

Please note that once the shipment has left your dealer or the Community factory, the responsibility for damage is always borne by the freight company. If damage has occurred during shipping, you must file a claim directly with the freight company. It's very important to contact the freight company as soon as possible after receiving your shipment, as most freight companies have a short time limit within which they will investigate claims. Make sure to save the carton and the packing material, as most claims will be denied if these materials are not retained. Your Community dealer and the factory will try to help in any way they can, but it is the responsibility of the party receiving the shipment to file the damage claim.

It is always a good idea to retain the carton and packing materials, if possible, in the event that the unit may need to be returned to your dealer or distributor for repair in the future.



CAUTION: Installation of I SERIES loudspeakers should only be performed by trained and qualified personnel. It is strongly recommended that a licensed and certified professional structural engineer approve the mounting. Severe injury and/or loss of life may occur if this product is improperly installed.

RIGGING SAFETY / IMPORTANT NOTES

There are three primary areas of responsibility for rigging loudspeakers. The first is the building structure. Always consult with the building architect or structural engineer to assure the ability of the structure to support the loudspeaker system. The second area of responsibility is the loudspeaker itself. Community certifies its loudspeaker systems and rigging accessories for suspension when they are properly installed according to our published guidelines. The third area of responsibility is everything between the loudspeaker and the building structure and the actual process of installation. The installing contractor assumes this responsibility. Loudspeaker rigging should be performed only by certified rigging professionals using certified rigging hardware chosen for the specific application. Prior to installation, the contractor should present a rigging plan, with drawing and detailed parts list, to a licensed structural engineer (P.E.) or architect for written approval.



IMPORTANT: I SERIES loudspeakers are designed and intended to be mounted to differing building surfaces using a variety of rigging hardware, means and methods. Installation of loudspeakers should only be performed by trained and qualified personnel. All electrical connections must conform to applicable city, county, state, and national (NEC) electrical codes.



DANGER: All rigging fittings must be fully tightened and secured. Any missing fasteners or parts will compromise the structural integrity of the enclosure and constitute a safety hazard. Over-tightening (crushing the wood) should be avoided as well. Do not suspend the loudspeaker unless all fasteners are securely in place!



IMPORTANT: The flat head bolts that come installed in each enclosure must remain in place or be replaced by a threaded fastener from an array bracket. The bolts attach to internal metal brackets that are critical to the structural integrity and rated Safe Working Load (SWL) of each point and each array assembly. Failure to include a fastener in every location could lead to serious injury, or even death.



DANGER: I SERIES rigging fittings are rated at a Working Load Limit (WLL) of 150 lbs (68 kg) with a 10:1 safety margin. No single rigging fitting should ever be subjected to a load that is greater than this stated limit. Failure to heed this warning could result in injury or death!

TABLE OF CONTENTS

1: Parts and Assembly

Safety Information.....	2
Hardware Guide.....	4
Modular Parts Guide.....	5-6
General Assembly Information.....	7-11

2: BalancePoint™ Fly Rails

BalancePoint™ Horizontal and Vertical Fly Rails (BFR22H/BFR22V).....	12-13
Subwoofer behind BalancePoint™ Fly Rails (SBR54).....	14-15

3: U-Brackets and Vertical Yokes

U-Brackets (IUB-1122, IUB-1152, IUB-1153).....	16
Vertical Yokes (IVY-0002, IVY-1122, IVY-1152, IVY-1153).....	17-18

4: Horizontal Array Kits

Isometric Array Frame 40"/54" (IAF40, IAF55).....	19-22
Dual Horizontal Splay Kit (HSB-BFR22, HSB3-BFR22).....	23-26
Dual Horizontal Splay with Extension Kit (HSB-SBR54, HSB3-SBR54).....	27-32
Dual Horizontal Array with Subwoofer Between Kit (HAB-BFR38, HAB3-BFR38)....	33-36

5: Vertical Array Kits

Dual Vertical Splay Kit (VSB-BFR22, VSB3-BFR22).....	37-42
Dual Vertical Splay with Extension Kit (VSB-SBR54, VSB3-SBR54).....	43-48
Vertical Array with Subwoofer Above Full-range Kit (VAB-BFR38).....	49-50
Dual Vertical Splay for Two Enclosures (DVS-BFR22).....	51-54

6: Array Accessory Kits

Downfill Splay Bracket Kit (DFS).....	55
Horizontal/Vertical Splay Bracket Kit (adds one enclosure) (HVS, HVS3).....	56-60
Tight Pack Kit (TPK).....	61

7: Technical Drawings (dimensions/hole placement)

Parts- Plates.....	62-63
Parts- Brackets.....	64-65
Parts- BalancePoint™ Fly Rails.....	66
Parts- U-Brackets.....	67-68
Parts- Vertical Yokes.....	68-70
Parts- Array Frames.....	71-72

8: Appendix

Advanced Array Configurations.....	73-74
Warranty.....	75
Kit Weights.....	75
Loudspeaker Weights.....	75

1 HARDWARE GUIDE (shown full-size)

Hardware Key
 H=HARDWARE
 F=Bolt (Flat Head)
 H=Bolt (Hex Head)
 L=Lock washer
 N=Nut, locknuts
 W= Washer

6mm HARDWARE

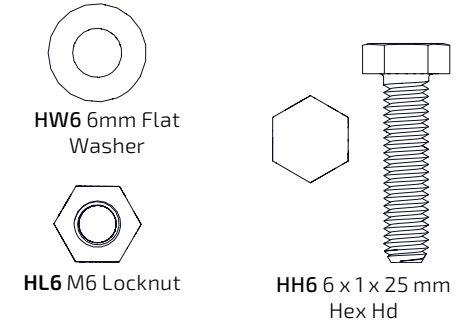

8mm HARDWARE

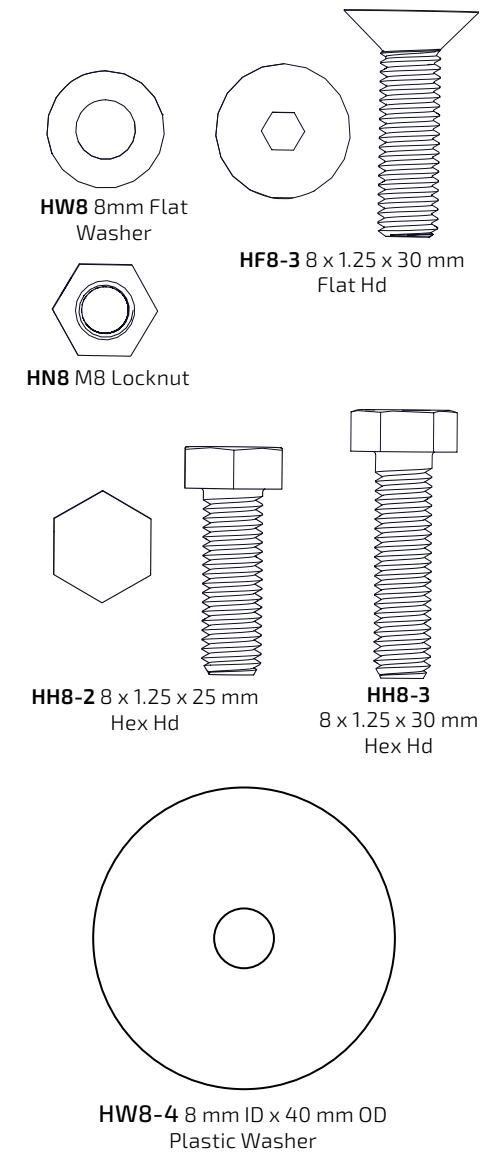

10mm HARDWARE

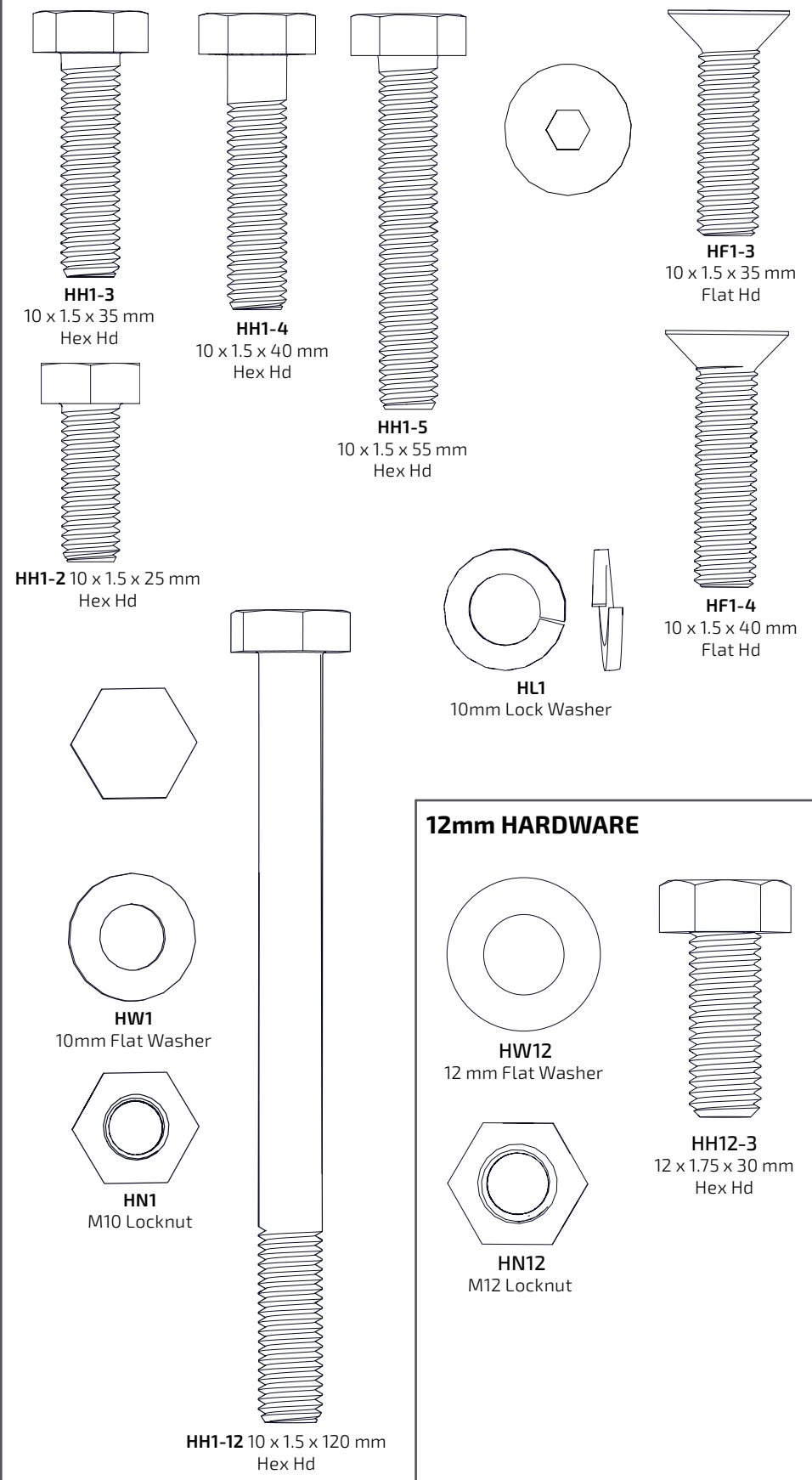

12mm HARDWARE

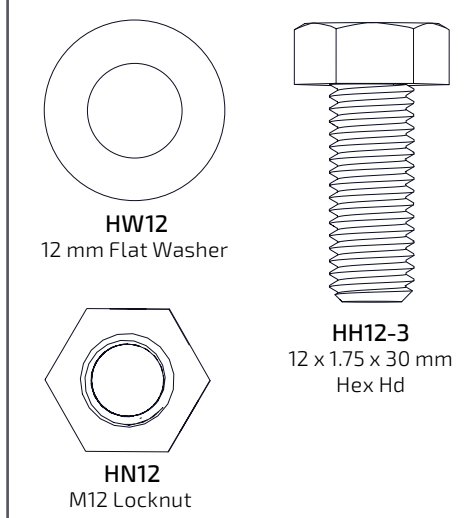

1 MODULAR PARTS GUIDE

Parts not shown to scale - for visual reference only

BRACKETS

Parts Key

P=PARTS	H=Hinge
B=Bracket	P= Plate
F= Frame	R= Rails

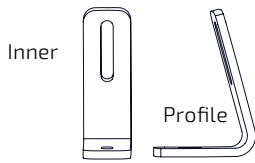

[PB-1] Single Horizontal L Bracket
Use in BFR22

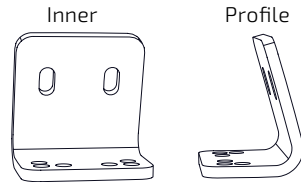

[PB-2] Dual Horizontal L Bracket
Use in VSB/VSB3-BFR22,
VSB/VSB3-SBR54

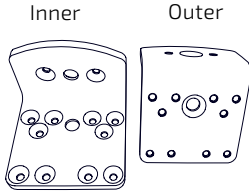

[PB-3] 2-way Cabinet Bracket
Use in DFS, DVS-BFR22,
HSB-BFR22, HSB-SBR54, HVS,
VSB-BFR22, VSB-SBR54

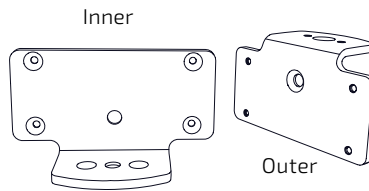

[PB-4] 3-way Cabinet Bracket
Use in HSB3-BFR22, HSB3-SBR54,
HVS3, VSB3-BFR22, VSB3-SBR54

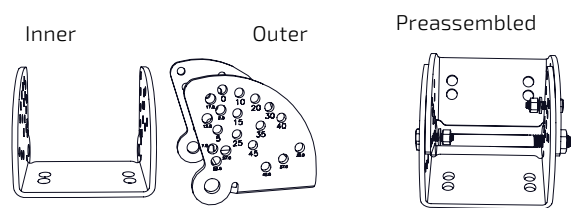

[PH] Hinge (Rotational Array) Bracket
(Ships preassembled)
Use in DFS, DVS-BFR22, HSB/HSB3-BFR22, HVS/HVS3,
VSB/VSB3-BFR22, VSB/VSB3-SBR54

PLATES

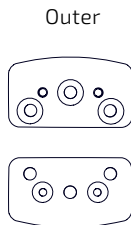

[PP-1] Universal Plate
Use in BFR22, TPK,
HSB/HSB3-SBR54,
SBR54, VAB-BFR38,
VSB/VSB3-BFR22,
VSB/VSB3-SBR54

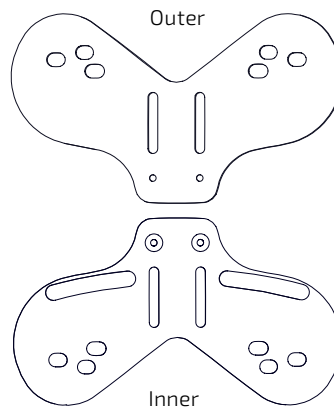

[PP-2] Splay Adapter Plate
Use in HSB/HSB3-BFR22,
HSB/HSB3-SBR22

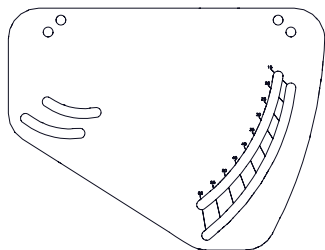

[PP-3] 2-Way Horizontal Array Plate
Use in HAB-BFR38

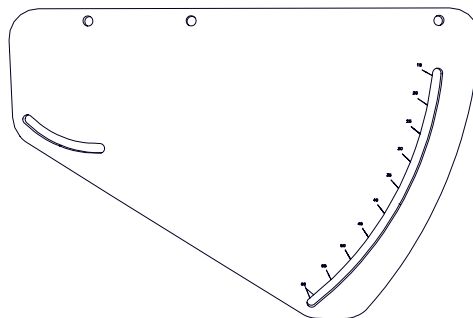

[PP-4] 3-Way Horizontal Array Plate
Use in HAB3-BFR38

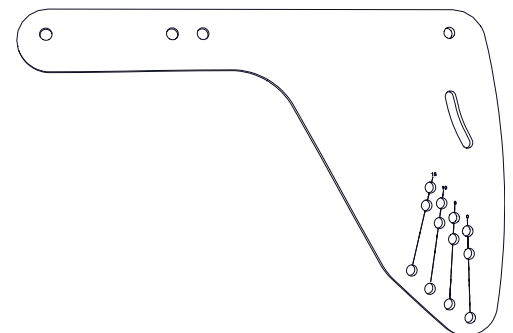

[PP-5] Vertical Array Plate
Use in VAB-BFR38

1 MODULAR PARTS GUIDE (continued)

Parts not shown to scale - for visual reference only

BALANCEPOINT™ FLY RAILS



[PR-1] 22" BalancePoint™ Fly Rails
Use in BFR22H, BFR22V, DVS-BFR22, HSB/HSB3-BFR22, VSB/VSB3-BFR22



[PR-2] 38" BalancePoint™ Fly Rails
Use in HAB/HAB3-BFR38, VAB-BFR38



[PR-3] 54" BalancePoint™ Fly Rails
Use in HSB/HSB3-SBR54, SBR54, VSB/VSB3-SBR54

Parts Key	
P=PARTS	H=Hinge
B=Bracket	P= Plate
F= Frame	R= Rails

ARRAY FRAMES

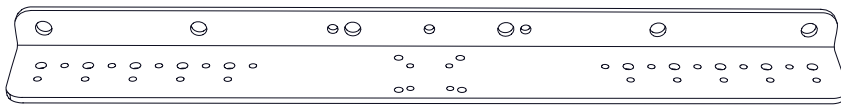

[PF-1a] 40" Isometric Array Frame
Use in IAF40

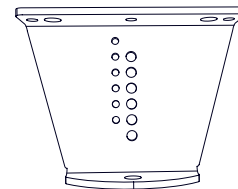

[PF-1b] 40" Array Frame Bracket

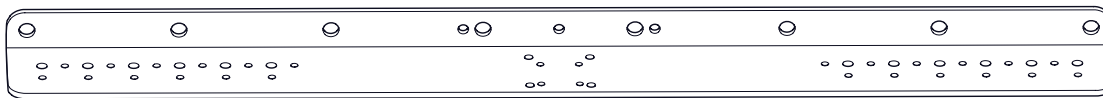

[PF-2a] 55" Isometric Array Frame
Use in IAF55

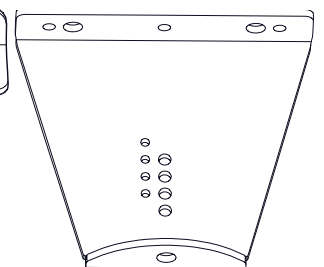

[PF-2b] 55" Array Frame Bracket

U-BRACKETS AND VERTICAL YOKES

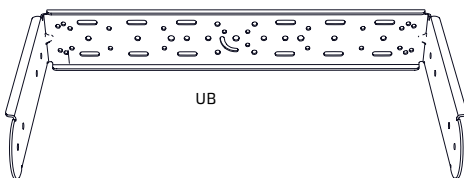

U-Brackets (IUB1152 shown)

IUB1122: Use for IP6-1122 and IP81122 models
IUB1152: Use for IP6-1152 and IP81152 models
IUB1153 - Use for IP81153 models

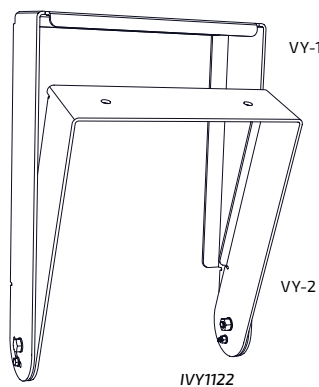

Vertical Yokes

VY-1: Vertical Yoke (attaches to bracket)
VY-2: Cabinet Bracket (attaches to cabinet)
(Ships preassembled)

IVY1122: Use for IP6-1122 and IP8-1122 models
IVY1152: Use for IP6-1152 and IP8-1152 models
IVY1153: Use for IP8-1153 models
IVY0002: Use for IP8-1151/IP8-0002 models

1 HELPFUL INSTALLATION TIPS

- Assemble the horizontal arrays on the ground (or lifting surface) and then lift the entire assembly into place. Large vertical arrays should be assembled top down - lifting each component and attaching it in order. Smaller vertical arrays can be assembled on the ground and then flown.
- Many brackets and plates come preassembled with the 8mm flat head hardware installed. Some of the corner brackets have differing bolt patterns and we preinstall them in the most common configuration for that kit. Refer to the diagrams on install pages to confirm that the bolts are in the correct position for your cabinet size.
- Assemble the array with the differing models (horn/coverage patterns) in the correct configuration.
- If the cabinets are horizontal, keep the input panels all on the same side for wiring ease, whenever possible.
- To determine the approximate splay or array angles prior to installation, use simulation software such as EASE®. Document those values, and set the angles on the hinges and splay plates as they are attached to the cabinets.
- When attaching corner brackets, thread both bolts in finger tight first, then continue to tighten equally with hex wrenches (helps avoid misalignment issues).
- Fully tighten the connections as each assembly is finished without crushing the wood fibers.
- The U-Brackets, Vertical Yokes and Isometric Frames have hole patterns compatible with third party manufacturers' adapter plates for 1-1/2" NPT rigid pole mounting systems (such as Chief CMA105 UL listed Ceiling mounting systems, with a SWL rating of 500 lbs [226.7 kg]). See manufacturer's website for details.
- Contact our Technical Assistance Group (TAG) for additional guidance by phone: (610) 876-3400 or email: tagteam@communitypro.com.

1 GENERAL ASSEMBLY INFORMATION

The BalancePoint™ Flyware kits for the I SERIES loudspeakers are modular and can be combined in a number of ways. The most common configuration of each kit is shown along with instructions for assembly.

Hardware and Parts: There is a key at the beginning of each instruction that shows the parts, their quantity and abbreviation. We also use a shortened code for the hardware that offers an easy reference to the type, diameter and approximate length.

ex: HW6 = Hardware Washer 6mm;
HF1-2 = Hardware, Flat head bolt, 10 x 25mm

Several parts have underside countersunk holes that are threaded for 8mm flat head bolts. They should be fully seated (at or below the surface of the piece) before attaching the plate/bracket to the enclosure. Bolt placement diagrams are shown for the cabinet brackets that have multiple holes. Several of the brackets are shipped with the 8mm flat head bolts already installed in the most common configuration for that kit.

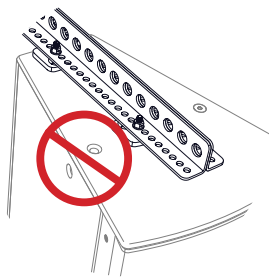

The loudspeaker enclosure must have fasteners in all threaded holes



IMPORTANT: The flat head bolts that come installed in each enclosure must remain in place or be replaced by a threaded fastener from an array bracket. The bolts attach to internal metal brackets that are critical to the structural integrity and rated Safe Working Load (SWL) of each point and each array assembly. Failure to include a fastener in every location could lead to serious injury, or even death.

TOOLS NEEDED FOR ASSEMBLY:

- Metric socket and ratchet set
- Metric wrench set
- Metric hex key set

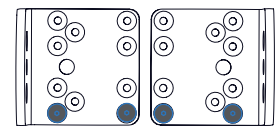

Typical bolt placement diagram for 2-way Cabinet (angle) Bracket (PB-3)

1 GENERAL ASSEMBLY INFORMATION (continued)

SAFETY CABLES

! **IMPORTANT:** Attach a safety cable to one of the unused mounting points on the loudspeaker (and/or the bracket assembly). Safety cables must be secured to a suitable load-bearing point separate from the loudspeaker mounting point, with as little slack as possible, oriented to minimize dynamic swinging of the load, so as not to develop undue shock or kinetic force if the loudspeaker mount were to fail. Safety cables and hardware are not included. Please consult a structural engineer for the appropriate cables, hardware, and location(s) for the load and application.

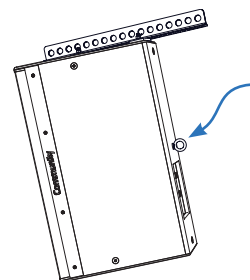

Typical placement for safety cable and hardware (eyebolt not included)

BALANCEPOINT™ FLY RAILS

Positioning:

- The fly rails may be mounted in any position required as long as all attachment points are used.
- For the best aesthetics, the fly rails should not extend beyond the front edge of the front cabinet.
- The fly rails can extend beyond the back of the cabinet.
- The rails should be attached to the cabinets using all of the connections shown in the instructions for each assembly. This will ensure that the cabinets don't rotate on the rigging and that the rigging is securely attached to the cabinets.
- In "Subwoofer Behind" configurations, the general rule of thumb is that there shouldn't be less than 6" (152mm) between the face of the subwoofer and the rear of the cabinet in front of it (allows sufficient air movement from the subwoofer cones and parts).

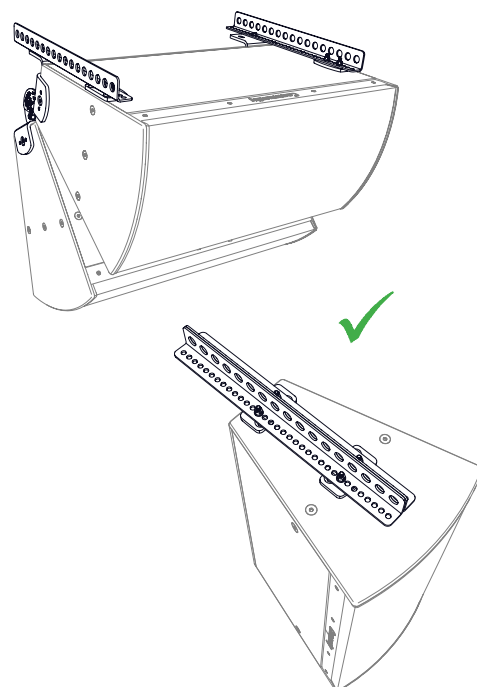

Flying:

- Optimally, each array should be lifted from the hole(s) on the fly rails that produce the desired tilt angle using gravity alone (the "Balance Point").
- A second cable may be used to fine-tune the exact aiming angle and/or stabilize the array from rotation as necessary.

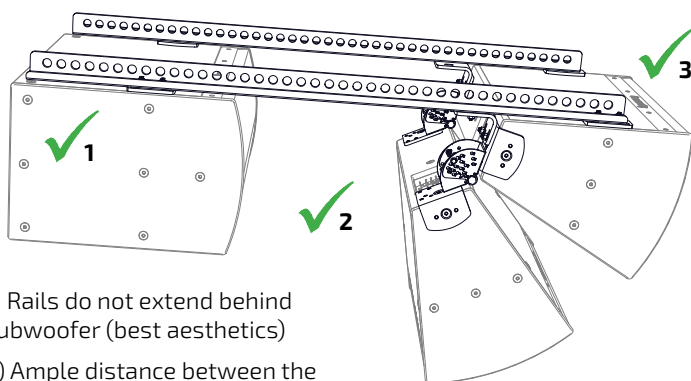

- 1) Rails do not extend behind subwoofer (best aesthetics)
- 2) Ample distance between the subwoofer and full-range cabinets
- 3) Fly rails well behind cabinet face

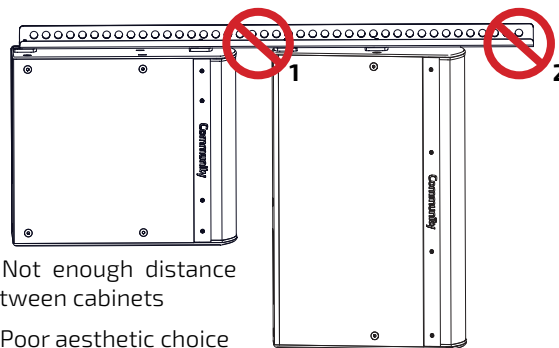

- 1) Not enough distance between cabinets
- 2) Poor aesthetic choice

1 GENERAL ASSEMBLY INFORMATION (continued)

ROTATIONAL (HINGE) BRACKET ANGLE EXPLAINED

The I SERIES full-range loudspeakers are in trapezoidal enclosures. The hinge bracket is used in many of the array kits to precisely set the angle between two loudspeakers. The hinges are shipped preassembled with the 6mm fasteners already in place. They will need to be removed to set your desired splay angle.

IMPORTANT: The splay angles printed on the rotational bracket indicate the angle between adjacent enclosure surfaces, not (in most cases) the center-to-center (C-C) loudspeaker aiming angles. For most horizontal and vertical arrays, the long trapezoidal sides of the enclosures will be adjacent. The total included trapezoidal cabinet angles are 30° therefore, the C-C loudspeaker aiming angles will be 30° greater than the enclosure splay angle indicated on the rotational bracket.

For example, if a C-C loudspeaker array angle of 45° is desired, the 6mm angle selection fasteners should be placed in the "15°" angle selection holes on the rotation brackets. 45° (C-C splay angle) - 30° (trapezoidal cabinet angles) = 15° (splay between adjacent enclosure surfaces).

When using the DVS-BFR22 or DFS kits, the non-angled top and/or bottom panels are adjacent, therefore, the loudspeaker aiming angle and adjacent enclosure surface splay angles are identical. For these kits, the angle selected on the rotational bracket is the same thing as the loudspeaker aiming angle.

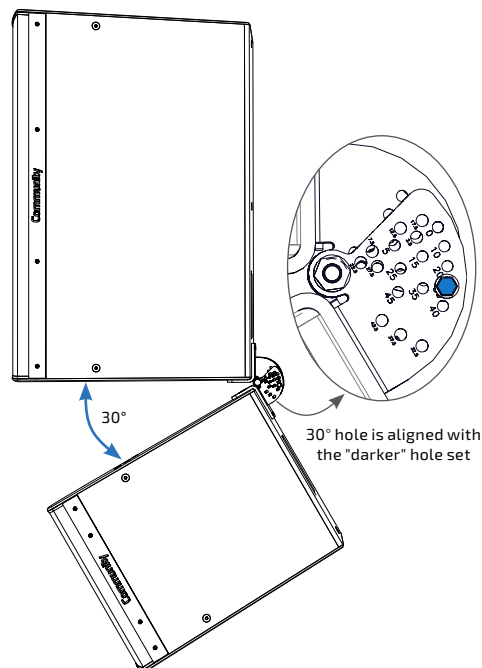

DFS kit shown with IP8-1153 and IP8-1151 30° splay shown which also equals the center-to-center measurement

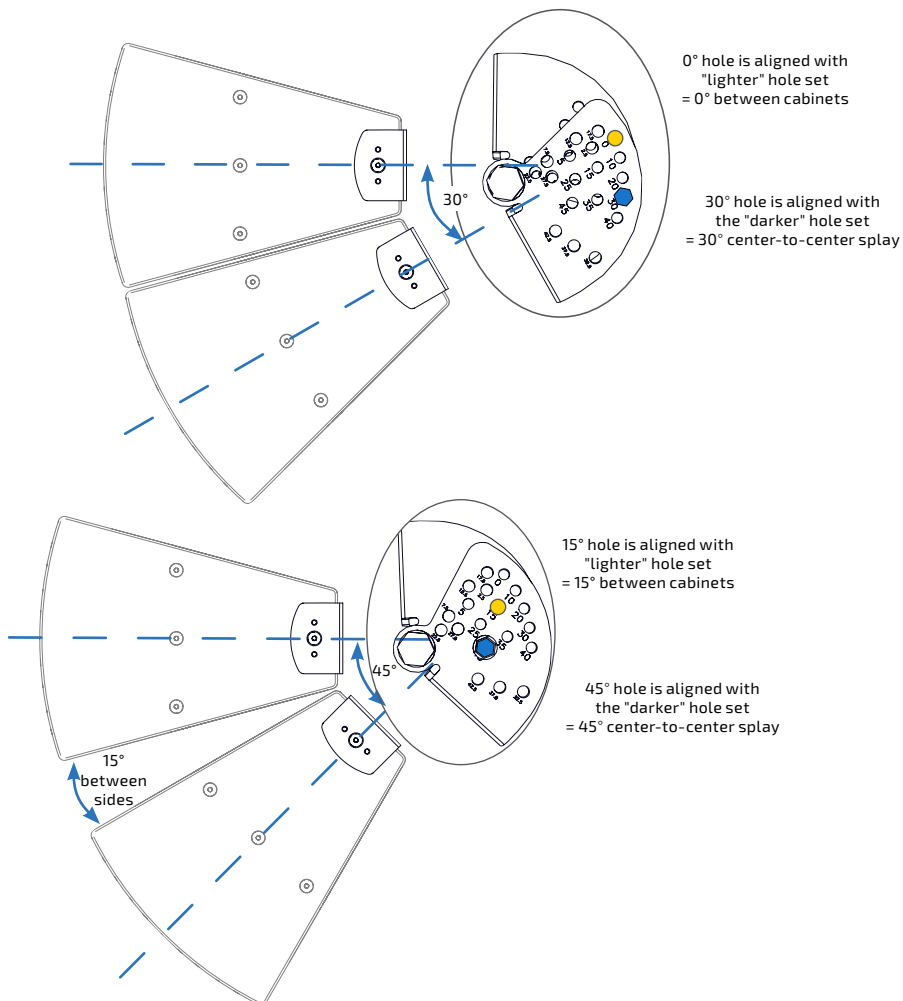

Basic cabinet geometry and aiming angles

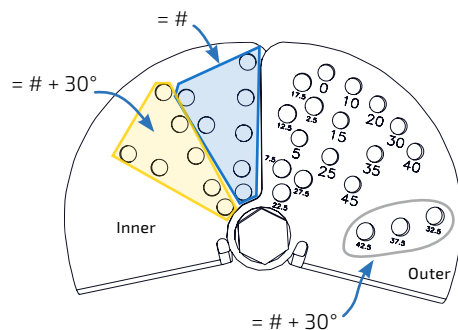

To set angle: For most applications, and to achieve center-to-center (C-C) angles greater than 45° you align the "lighter" set of holes with the marked degree. This number equals the angle between the loudspeakers, and you should add 30 to get the C-C measurement. To achieve 62.5°, 67.5°, or 72.5° (C-C) splay, the circled outside holes only align with the holes in the "darker" marked area.

Aligning the "darker" set of holes with the marked degree hole equals that angle between centers, and should be used for downfill (DVS-BFR22, DFS) kits.

1 GENERAL ASSEMBLY INFORMATION (continued)

GENERAL ROTATIONAL (HINGE) BRACKET INFORMATION

Figures showing the basic assembly and how to secure the angles are shown below.

IMPORTANT: Each hinge is shipped preassembled with a 10mm hinge bolt and locknut fastened to allow some movement. Once the angle is permanently set (and confirmed by commissioning the system), the locknut should be tightened to prevent any movement. Do not remove the locknut or hinge bolt for any reason.

Each hinge assembly also has two 6mm fasteners with finger-tight lock nuts inserted into angle selection holes on each side of the hinge. Both 6mm fastener sets may be removed for assembly but must all be re-inserted and fully tightened in accordance with each kit's specific assembly instructions.

Angles may be adjusted in 2.5° increments from 0° to 45° in any array configuration. Although it is possible in some configurations, do not exceed a splay angle of 45° (between adjacent sides).

Best practices: Orient the fasteners in the hinges to follow the direction of gravity; i.e. if the hinge will be used with the hinge bolt vertically oriented, position the hinge with the nut at the bottom to prevent the bolt from falling out if the nut should loosen.

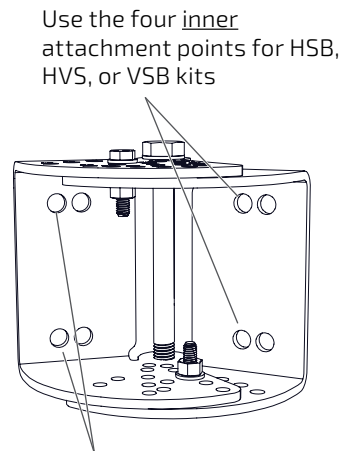
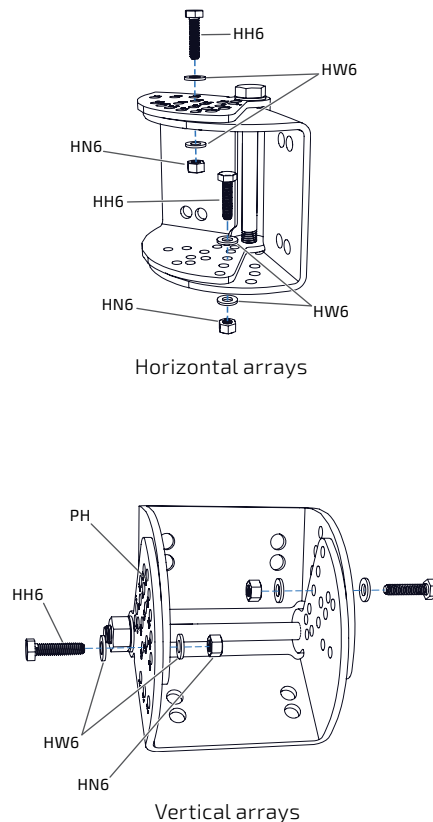
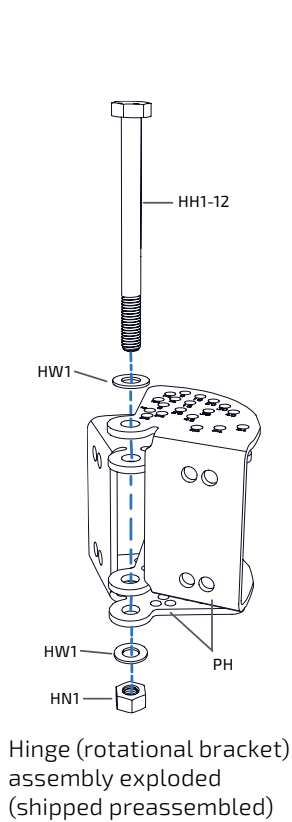

Use the four outer attachment points in DFS and DVS-BFR22 configurations

The hinge brackets have 2 sets of holes to attach the hinges to the cabinets. Bolt placement diagrams showing connection to the cabinet brackets are in each of the individual kit instructions.

Secure angle with 6mm fasteners. The hinge is shipped with the fasteners in the 45° holes.

1 GENERAL ASSEMBLY INFORMATION (continued)

! SIZE MATTERS!: When assembling vertically arrayed or splayed combinations ensure that the height of the loudspeakers is the same height as the subwoofer. Please note: the IS6/8-1152s are not the same height as any of the I SERIES dual subwoofers.

For horizontal arrays, any size of subwoofer may be paired with any size full-range enclosure in most arrays. Horizontal arrays attach only to the top of the cabinets.

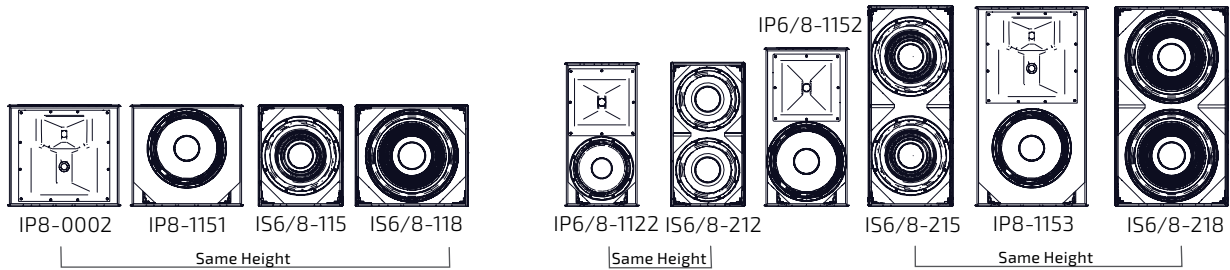

2 BALANCEPOINT™ FLY RAILS

BFR22H - 22" BalancePoint™ Horizontal Fly Rails

APPLICATION: Suspend and aim a single full-range loudspeaker or subwoofer from ceilings, walls, trusses, etc in landscape (horizontal) orientation.

Parts:

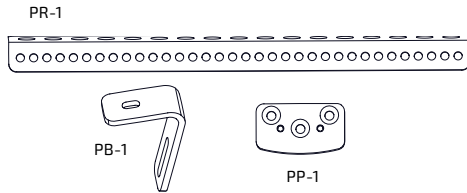

PR-1: 22" BalancePoint™ Fly Rails (2)
 PB-1: Horizontal Fly Rail L-brackets (2)
 PP-1: Universal Fly Rail Plates (2)

Hardware:

Qty	Code	Description
12	HW8	8mm Flat Washers
8	HN8	M8 Locknuts
4	HH8-2	8 x 25 mm Hex Hd Bolts
4	HF8-3	8 x 30 mm Flat Hd Bolts
2	HW1	10mm Flat Washers
2	HL1	M10 Lock Washers
2	HF1-3	10 x 35 mm Flat Hd Bolts
2	HH1-4	10 x 40 mm Hex Hd Bolts

Some 8mm hardware listed above will be included in plate preassemblies.

Kit Weight: 12.0 lb (5.4 kg)

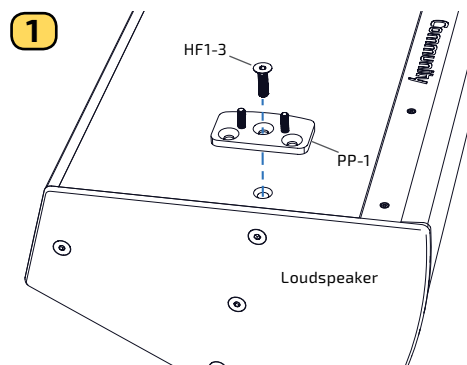
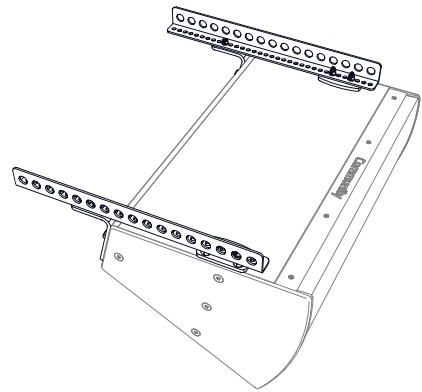

Figure 1-1. Attach PP-1 to enclosure - with outside edges parallel and fully tighten

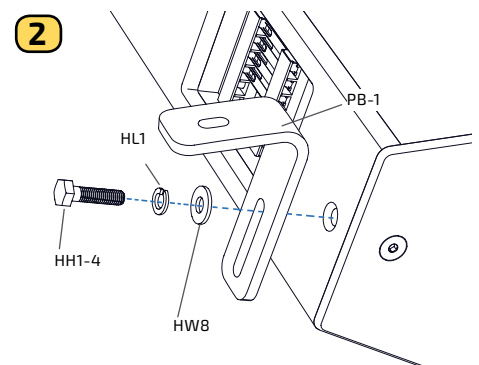

Figure 1-2. Attach PB-1 to enclosure - do not fully tighten

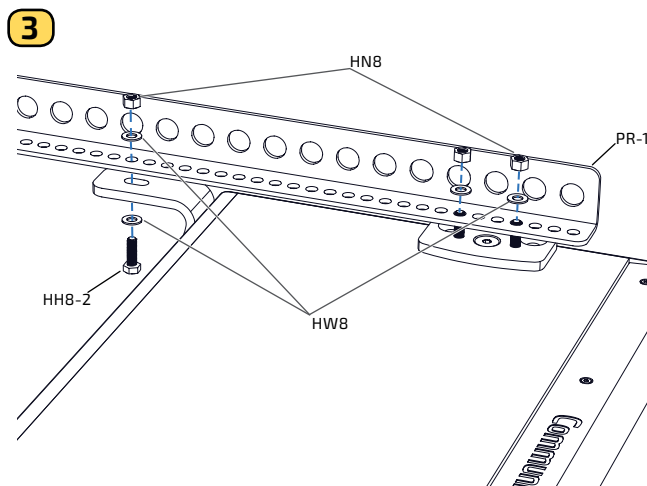

Figure 1-3. Attach rails to PP-1 / PB-1

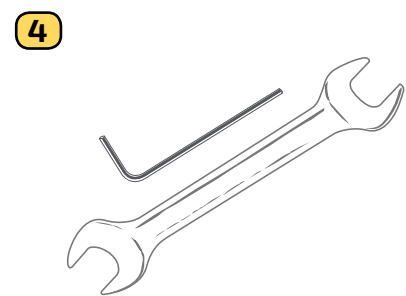

Figure 1-4. Fully tighten all connections

Note: When attaching to a IP8-1153 or IS6/8-218 cabinet, the front and rear bolt connections will be in the end holes of the rails.

2 BALANCEPOINT™ FLY RAILS

BFR22V - 22" BalancePoint™ Vertical Fly Rails

APPLICATION: Suspend and aim a single full-range loudspeaker (shown) or subwoofer from ceilings, walls, trusses, etc in portrait (vertical) orientation.

Parts:

PR-1



PP-1



PR-1: 22" BalancePoint™ Fly Rails (2)
PP-1: Universal Fly Rail Plates (2)

Hardware:

Qty	Code	Description
12	HW8	8mm Flat Washers
8	HN8	M8 Locknuts
4	HF8-3	8 x 30 mm Flat Hd Bolts
4	HH8-2	8 x 25 mm Hex Hd Bolts
2	HF1-3	10 x 35 mm Flat Hd Bolts

Some 8mm hardware listed above will be included in plate preassemblies.

Kit Weight: 9.0 lb (4.1 kg)

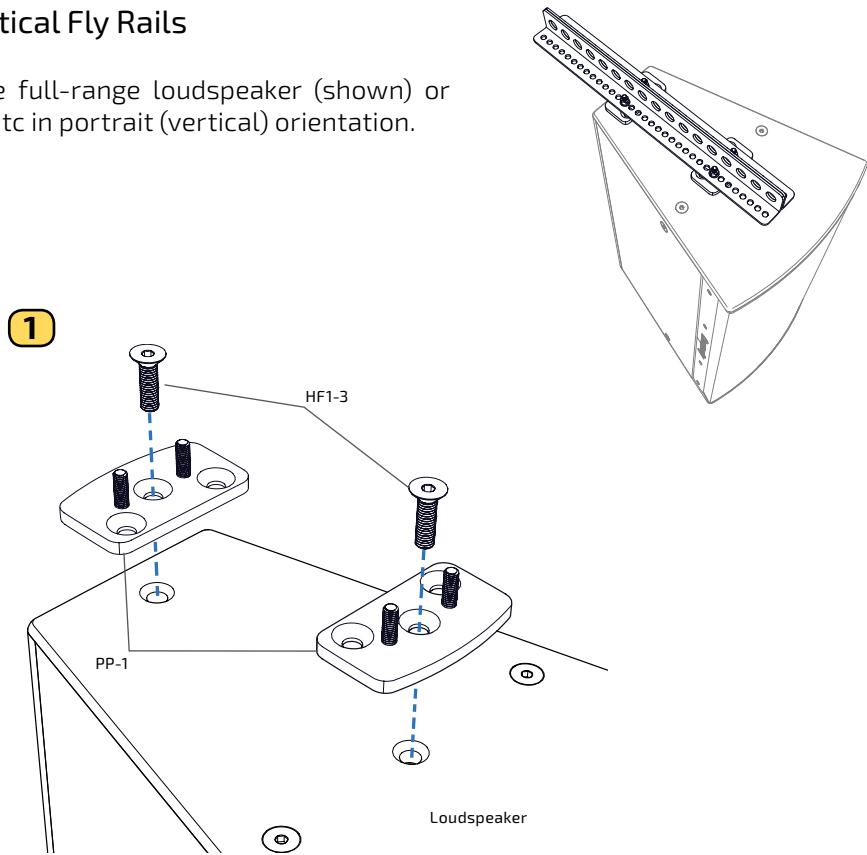

Figure 2-1. Attach PP-1 to enclosure

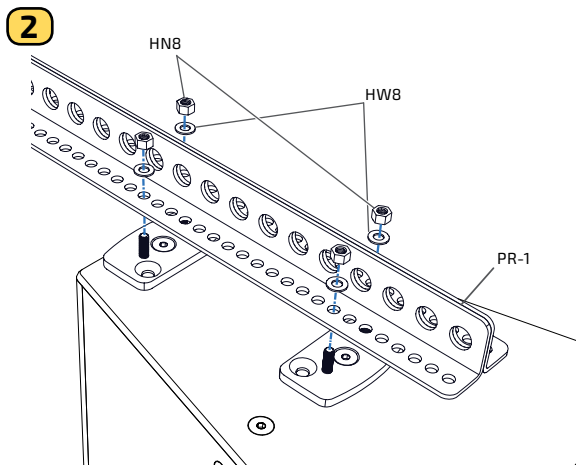

Figure 2-2. Attach rails to PP-1

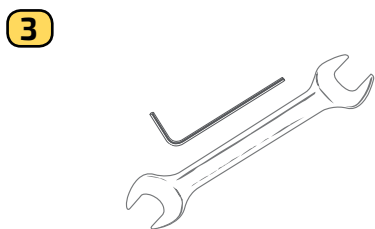

Figure 2-3. Fully tighten all connections

ADVANCED CONFIGURATIONS

The Fly Rails can be connected to Isometric Array frames, U-Brackets and Vertical Yokes. Connect the rails using 8mm hardware included in this kit. Fully tighten hardware before suspending the assembly.

The assembly should hang level and multiple lift points should be utilized. Lift points at the COG of each frame, yoke or u-bracket assembly or subwoofer cabinet.

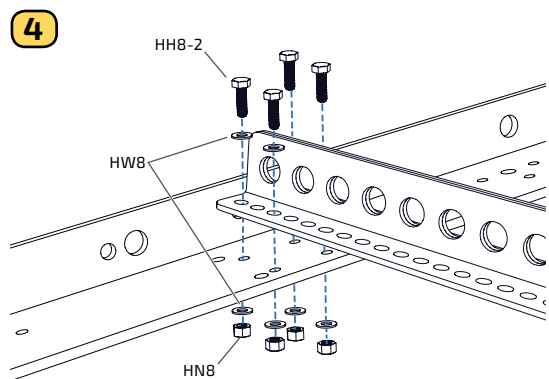

Figure 2-4. Typical connection of rails to the IAF40 (shown) or IAF55 isometric array frame

2 BALANCEPOINT™ FLY RAILS

SBR54 - Subwoofer Behind BalancePoint™ Fly Rails

APPLICATION: Suspend single or dual subwoofers behind a full-range loudspeaker (or loudspeaker array) from ceilings, walls, trusses, etc in vertical or horizontal orientation.

Parts:

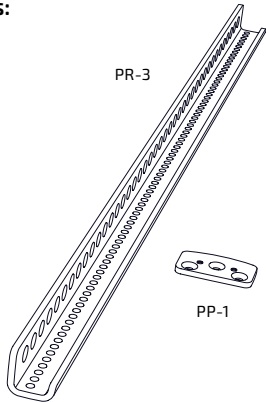

PR-3: 54" BalancePoint™ Fly Rails (2)
PP-1: Universal Fly Rail Plates (6)
 Gasket Material

Hardware:

Qty	Code	Description
12	HF8-3	8 x 30 mm Flat Hd Bolts
16	HN8	M8 Locknuts
20	HW8	8mm Flat Washers
8	HF1-3	10 x 35 mm Flat Hd Bolts
4	HH8-2	8 x 25 mm Hex Hd Bolts

Some 8mm hardware listed above will be included in plate preassemblies. Extra 8mm hardware is included for potential attachment to a single Vertical Yoke, U-Bracket or Array Frame. Extra PP-1 plate assemblies and hardware are included to make horizontally oriented full-range/subwoofer configurations.

Kit Weight: 20.0 lb (9.1 kg)

Dual Subwoofers:

Vertical Orientation: Use included PP-1s to attach the cabinets at the top and bottom.

Horizontal Orientation: Purchase of a Tight Pack kit (TPK) is necessary when hanging dual subwoofers horizontally. They must be connected two (2) places on each side.

Notes:

Vertical Orientation: Each rail must be aligned and secured to two (2) points on each cabinet. For best aesthetics, the rails should not overhang the front edge of the full-range cabinet.

Horizontal Orientation: Each rail will be attached to one (1) PP-1 on the full-range cabinet and to two (2) PP-1s on the subwoofer. Go to step 2c to start.

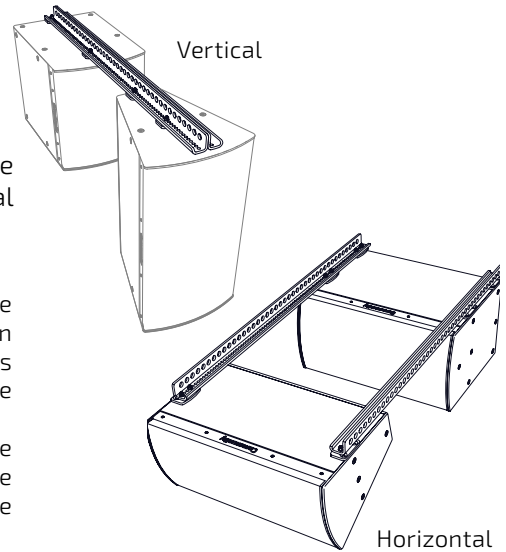

1 Full-range (Vertical orientation only)

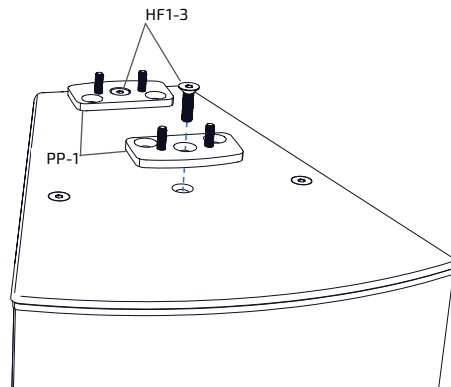

Figure 3-1. Remove original bolts and attach two (2) PP-1 to the full-range cabinet

2a Single Subwoofer (Vertical orientation)

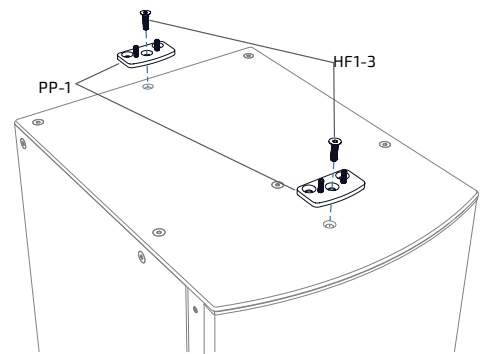

Figure 3-2a. Attach two (2) PP-1 to the front and rear connection points on the subwoofer

2b Dual Subwoofers (Vertical orientation)

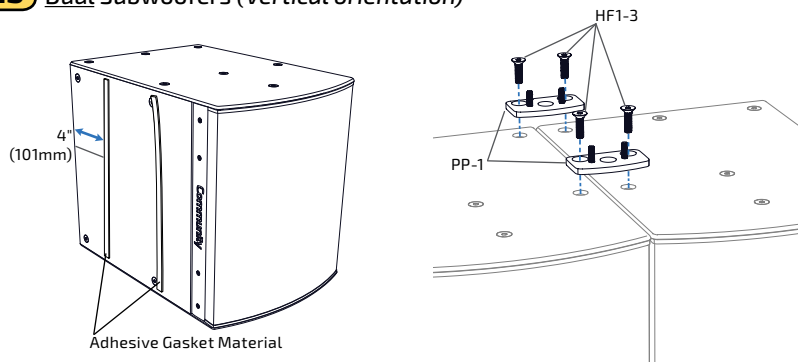

Figure 3-2b. Cut and adhere (2) strips of gasket to the side of one subwoofer (spanning the height and spaced equidistant). With the gasket sandwiched between the cabinets, attach (2) PP-1 at the top (shown), another pair on the bottom and fully tighten connections.

2 BALANCEPOINT™ FLY RAILS

SBR54 (continued)

2c Subwoofer and Full-range (Horizontal orientation)

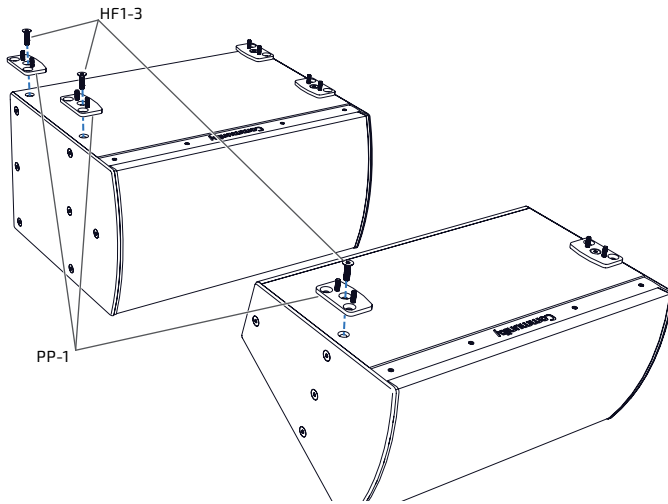

Figure 3-2c. Attach four (4) PP-1 to the connection points on the subwoofer, and two (2) PP-1 to the connection points on the full-range cabinet

3

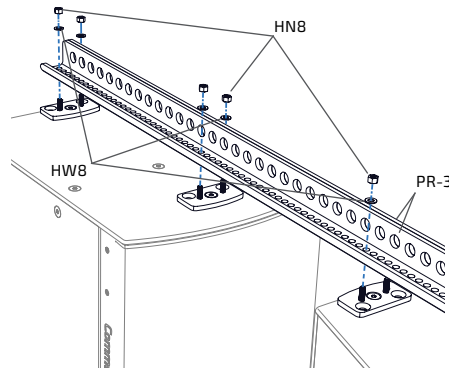

Figure 3-3. Attach the Rails to the PP-1 assemblies previously attached to the cabinets (single subwoofer, vertical orientation shown)

4

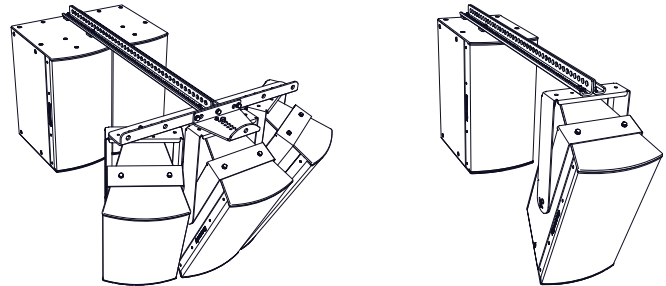

Figure 3-4. Fully tighten **all** connections before lifting

ADVANCED CONFIGURATIONS

The Fly rails can be connected to single U-Brackets, Vertical Yokes or the Isometric Array frames. Connect the rails using 8mm hardware included in this kit. Fully tighten hardware before suspending the assembly.

The assembly should hang level and multiple lift points should be utilized. Lift points at the COG of each frame, yoke or u-bracket assembly or subwoofer cabinet.



5

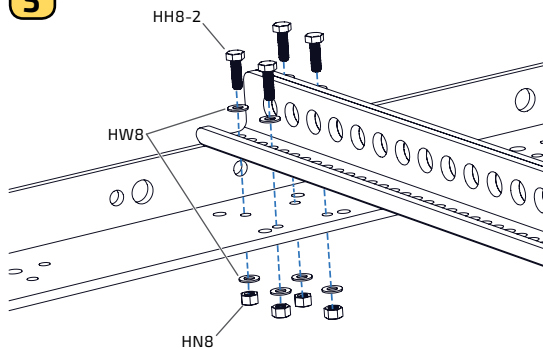

Figure 3-5. Typical connection of rails to the IAF40 (shown) or IAF55 isometric array frame

6

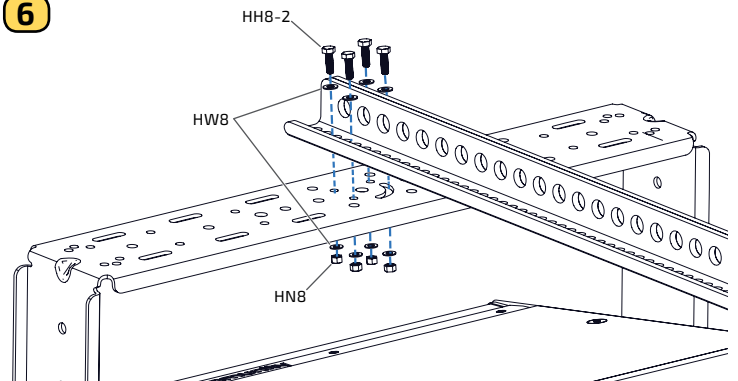

Figure 3-6. Typical connection of rails to a single Vertical Yoke or U-Bracket (shown)

3 U-BRACKETS

IUB1122 - U-Bracket for IP6-1122, IP8-1122

IUB1152 - U-Bracket for IP6-1152, IP8-1152 (*shown*)

IUB1153 - U-Bracket for IP8-1153

APPLICATION: Suspend and aim single loudspeakers from ceilings, walls, trusses, etc in portrait or landscape orientation.

Before assembly: Adhere the rubber washers to the inside of the yoke (aligned with cabinet mounting point).

Note: The yoke can be attached to the building structure and then the loudspeaker can be installed later.

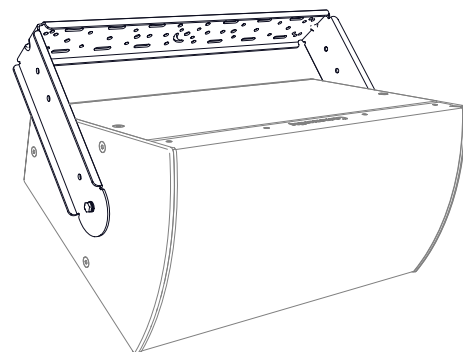

Parts:

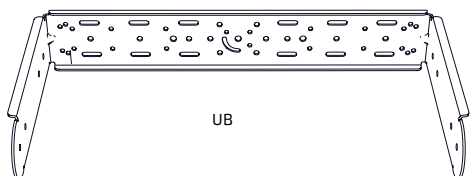

UB: U-Bracket

Hardware:

Qty	Code	Description
2	HH1-4	10 x 40 mm Hex Hd Bolts
2	HW1	10 mm Flat Washers
2	HL1	10 mm Lock Washers
2	HW8-4	8mm ID x 40mm OD Black Rubber Washer

The u-bracket is shipped preassembled and ready to attach to the cabinet.

Kit Weights:

- IUB1122: 16.0 lb (7.3 kg)
- IUB1152: 17.0 lb (7.7 kg)
- IUB1153: 22.0 lb (10.0 kg)

Can also be used with: a downfill bracket to provide pan capability for two vertically oriented loudspeakers [DFS bracket or DVS-BFR22], BalancePoint™ Fly Rails, or to array two (2) loudspeakers horizontally on IAF40 or IAF55 frames.

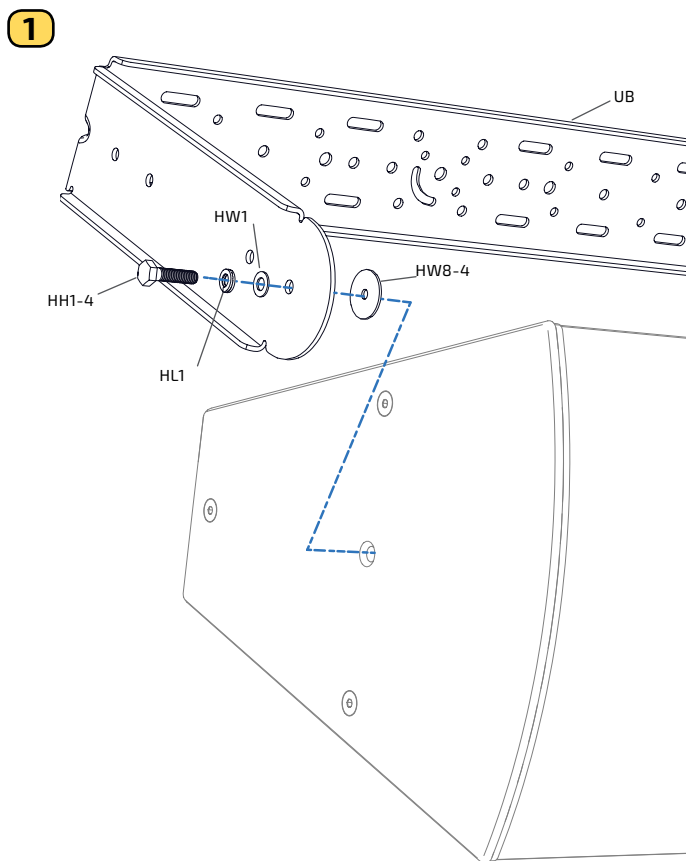
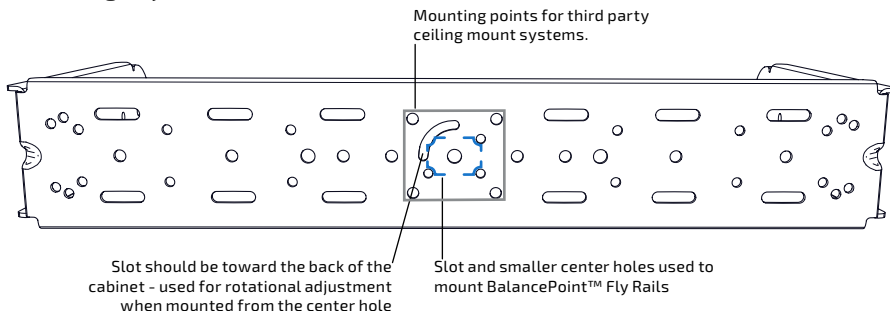
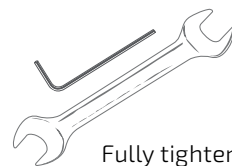

Figure 4-1. Remove middle cabinet bolts and attach yoke to cabinet

Mounting Key



2



Fully tighten **all** connections

3 VERTICAL YOKES

IVY1122 - Vertical Yoke for IP6-1122, IP8-1122

IVY1152 - Vertical Yoke for IP6-1152, IP8-1152 (*shown*)

IVY1153 - Vertical Yoke for IP8-1153

APPLICATION: Suspend and aim single loudspeakers vertically (in portrait orientation) from ceilings, walls, trusses, or use with array frames.

Assembly note: Orient vertical yoke so that the side bends are toward the rear of the cabinet.

Note: The yoke can be attached to the building structure and then the loudspeaker can be installed later.

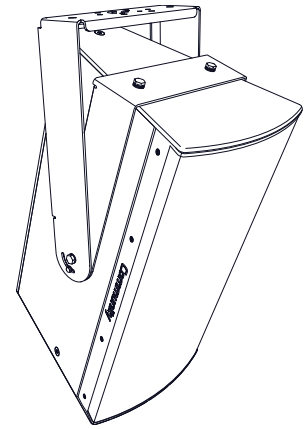

Parts:

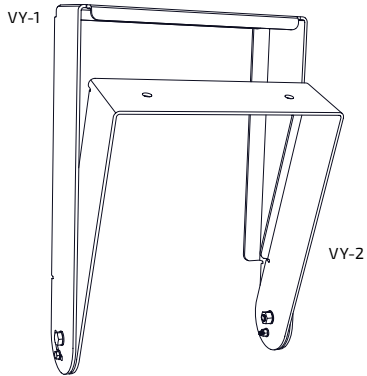

VY-1: Vertical Yoke
VY-2: Yoke Cabinet Bracket

Hardware:

Qty	Code	Description
4	HW6	6mm Flat Washers
2	HN6	M6 Locknuts
2	HH6	6 x 25 mm Hex Hd Bolts
2	HH1-2	10 x 25 mm Hex Hd Bolts
2	HH1-3	10 x 35 mm Hex Hd Bolts
2	HN1	M10 Locknuts
6	HW1	10 mm Flat Washers
2	HL1	10 mm Lock Washers

The yoke is shipped preassembled and ready to attach to the cabinet.

Kit Weights:

IVY1122: 21.0 lb (9.5 kg)

IVY1152: 23.0 lb (10.4 kg)

IVY1153: 25.0 lb (11.3 kg)

Also used with:

Isometric Array Frames (IAF40 / IAF55)
and BalancePoint™ Fly Rails

1

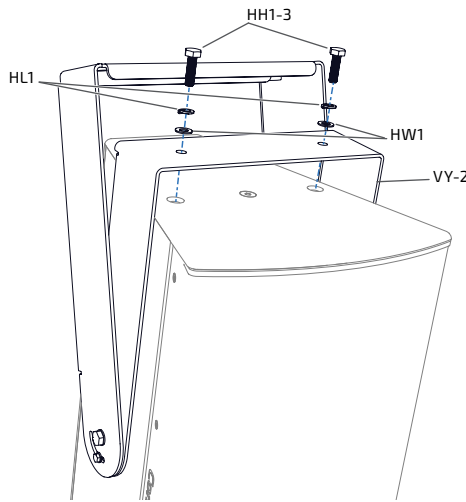

Figure 5-1. Attach bracket to cabinet

2

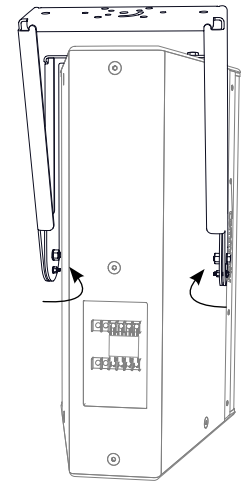

Figure 5-2. Fully tighten hardware to secure angle

3

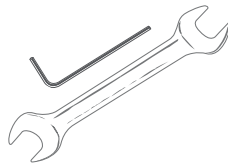
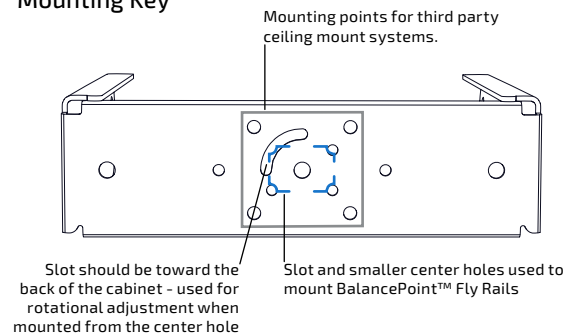

Figure 5-3. Fully tighten all connections

Mounting Key



Slot should be toward the back of the cabinet - used for rotational adjustment when mounted from the center hole

Mounting points for third party ceiling mount systems.

Slot and smaller center holes used to mount BalancePoint™ Fly Rails

3 VERTICAL YOKES

IVY0002 - Vertical Yoke for IP8-0002, IP8-1151

APPLICATION: Suspend and aim single loudspeakers from ceilings, walls, trusses, or use with array frames.

NOTE: Orient cabinet bracket and yoke so that the side bends are toward the rear of the cabinet. The yoke can be preinstalled (attached to the structure) and then the loudspeakers can be installed later.

PREASSEMBLY: The yoke comes preassembled to allow a 0°-45° downtilt. If you need a 45-60° downtilt, move the bolts down to the lowest hole setting. A lower profile (with less degrees of downtilt) can be obtained by moving the bolt positions up as shown at right).

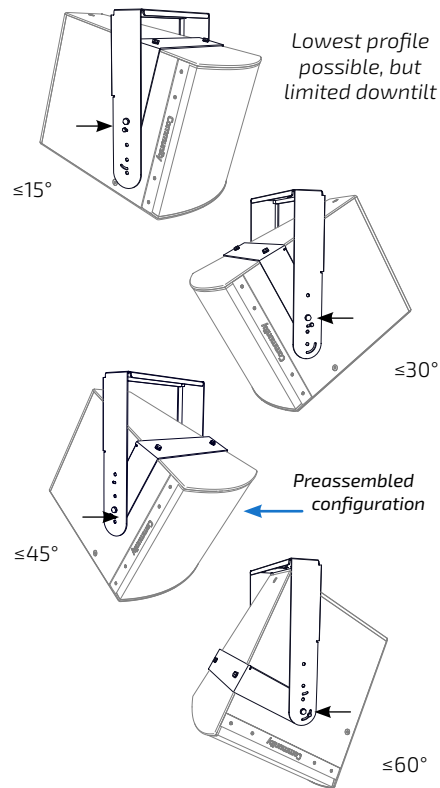
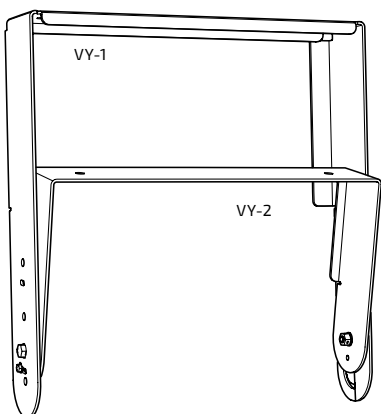

Figure 6-1. Attachment points to cabinet bracket are determined by desired angle/range of downtilt

Parts:



VY-1: Vertical Yoke
VY-2: Yoke Cabinet Bracket

Hardware:

Qty	Code	Description
2	HW6	6mm Flat Washers
1	HN6	M6 Locknuts
1	HH6	6 x 25 mm Hex Hd Bolts
2	HH1-2	10 x 25 mm Hex Hd Bolts
2	HH1-3	10 x 35 mm Hex Hd Bolts
2	HN1	M10 Locknuts
6	HW1	10 mm Flat Washers
2	HL1	10 mm Lock Washers

The yoke is shipped preassembled in the ≤45° setting and is ready to attach to the cabinet.

Kit Weight: 23.0lb (10.4 kg)

Also used with: IAF55 Isometric Array Frame and BalancePoint™ Fly Rails

1

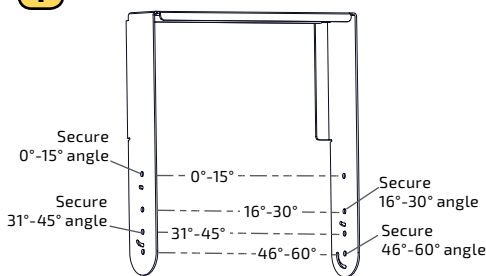

2

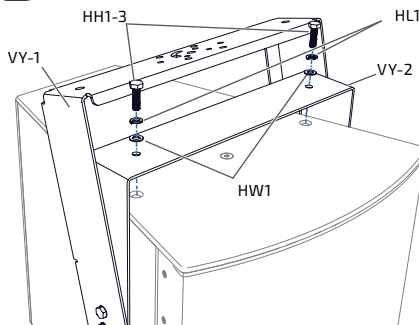

Figure 6-2. Attach bracket to cabinet

3

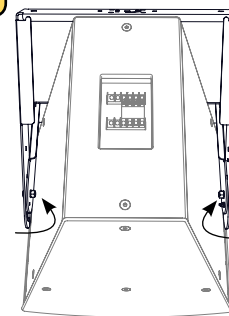

Figure 6-3. Fully tighten hardware to secure angle

4



Figure 6-4. Fully tighten all connections

Mounting Key

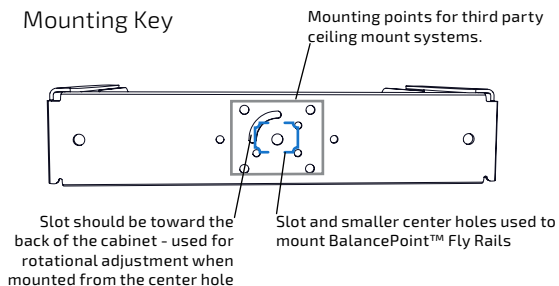

4 HORIZONTAL ARRAYS

IAF40 - 40" Isometric Array Frame for 12"-15" 2-way Loudspeakers

APPLICATION: Suspend and aim two or three full-range 2-way loudspeakers in an isometric array.

NOTES: The array can be assembled standing on the ground and then the tilt angles can be adjusted when lifted.

- Loudspeakers must be fitted with Vertical Yokes or U-Brackets (3x IVY1122/IPB-1122s are shown)
- If the frame is suspended from a central point(s) the array must be symmetrical - same size outside loudspeakers at the same angle and tilt
- The center frame bracket is not necessary for dual loudspeaker configurations, but attaching it adds an extra forward lift point.

PREASSEMBLY:

Attach the Vertical Yokes or U-Brackets to the loudspeakers (see Vertical Yoke, or U-Bracket instructions).

For 3-cabinet arrays: The frame bracket must be attached to the frame.

For 2-cabinet arrays with loudspeakers in vertical or horizontal orientation: The frame bracket is optional, but provides an extra forward lift point for the rigging. The loudspeakers should be symmetrically oriented and attached to the frame. The front grilles should form an arc.

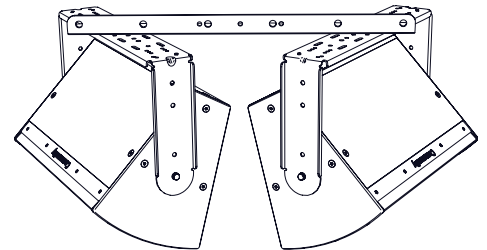
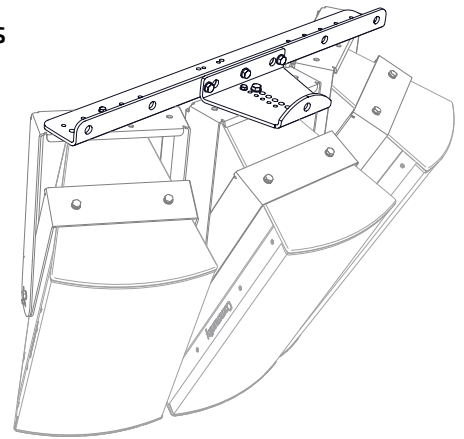

Parts:

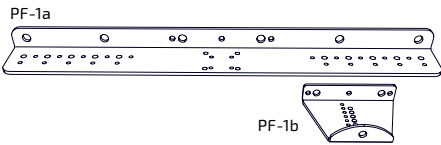

Allows up to 45° of pan/tilt within a 3-cabinet array of 12/15" 2-way loudspeakers

PF-1a: Isometric Array Frame

PF-1b: Frame Bracket

Hardware:

Qty	Code	Description
3	HH8-2	8 x 25 mm Hex Hd Bolts
3	HN8	M8 Locknuts
6	HW8	8mm Flat Washers
6	HH12-3	12 x 30 mm Hex Hd Bolts
6	HN12	M12 Locknuts
12	HW12	12 mm Flat Washers

Note: There should not be any leftover hardware, unless only two (2) loudspeakers are mounted to the frame.

Kit Weight: 33.0lb (15.0 kg)

MUST BE USED WITH: 2-3 Vertical yoke brackets or 2 U-Brackets horizontally.

Additional Configuration: A smaller fill loudspeaker or subwoofer can be added under the middle loudspeaker on a 3-cabinet array by using a DFS Downfill or DVS-BFR22 kit.

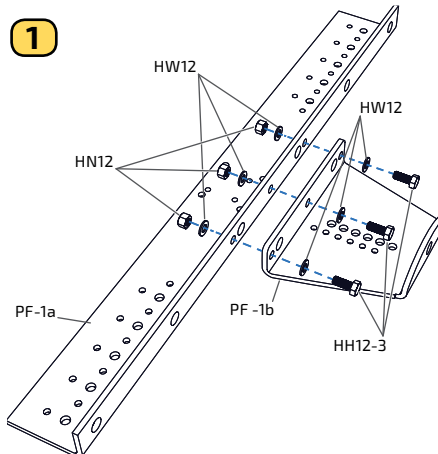
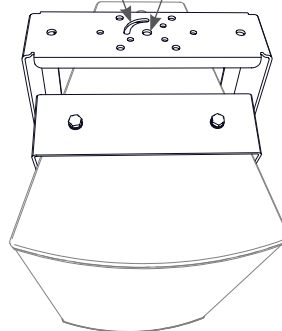

Figure 7-1. Attach bracket to array frame for 3-cabinet arrays or for extra stabilization on 2-cabinet arrays

2

Use 8mm hardware to set bracket pan angle
12mm hardware -Primary mounting point



Use 8mm hardware to set bracket pan angle
12mm hardware -Primary mounting point

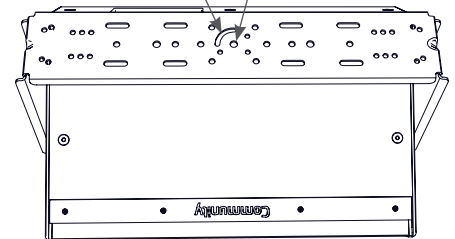

Figure 7-2. Yoke/U-Bracket mounting points

4 HORIZONTAL ARRAYS

IAF40 (continued)

3

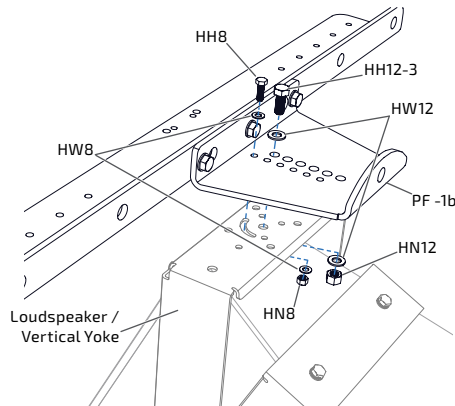

Figure 7-3. Mount center loudspeaker

4

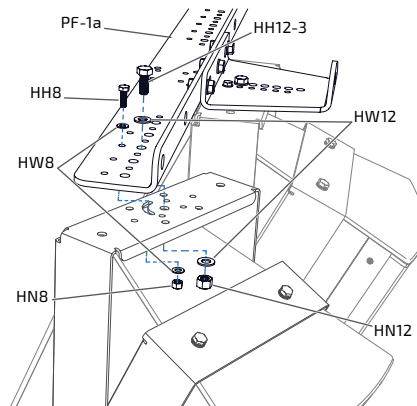
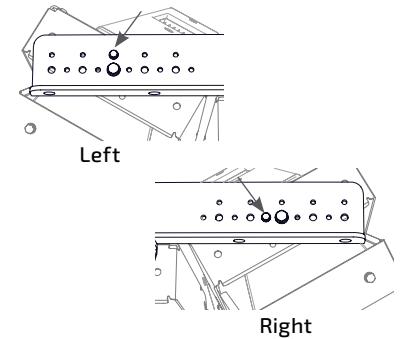
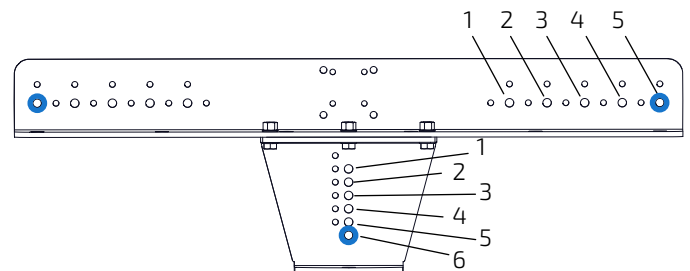
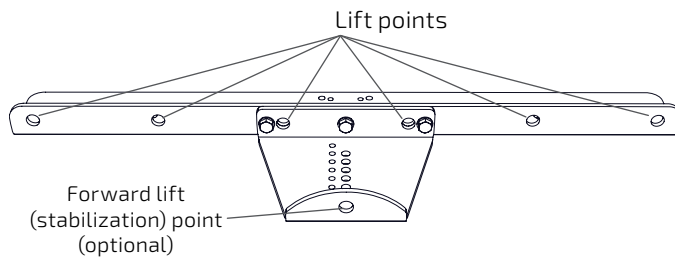

Figure 7-4 . Mount outside loudspeakers



8mm bolts line up with slots in yokes for panning adjustability (arrows)



Degrees of **symmetrical** rotation and tilt for 3 (2-way) cabinets in vertical yokes
ex. Cabinets mounted at holes 5/6 (heavy circles), provide a maximum 45° pan and 45° tilt for each cabinet.

Hole Position* (Bracket)	Frame				
	1	2	3	4	5
1	—	—	—	30°	40°
2	—	—	—	30°	40°
3	—	—	—	30°	40°
4	—	—	—	30°	40°
5	—	—	20°	35°	45°
6	—	—	20°	35°	45°

*Mounting positions as marked on the frame graphic

This chart is provided as a starting point. Tighter arrays using the 1-4 holes can be achieved with the smaller IP6/8-1122 models, but will provide a lesser degree of tilt for 3 cabinets.

IMPORTANT

- Table at right shows the maximum symmetrical pan and tilt for a three cabinet array. Cabinets can be placed more closely but will have less rotation and/or tilt capabilities.
- 2-cabinet horizontal arrays should always mount to the outside (#5) holes on the frame for full rotation.
- The frame should be level when suspended and the pan and tilt is achieved by adjusting the yokes and the loudspeakers.
- BalancePoint™ Fly Rails can be added to the frame (attached right behind the middle bolt connection) to add subwoofers behind or additional lift or stabilization points.
- No more than three (3) Full-range and two (2) subwoofers should be on any single connected configuration. Do not exceed the Safe Working Load (500 lbs) of the assembly. Loudspeaker weights are provided on the last page of this manual.



It is strongly recommended that a licensed and certified professional structural engineer approve the mounting. Severe injury and/or loss of life may occur if this product is improperly installed.

4 HORIZONTAL ARRAYS

IAF55 - 55" Isometric Array Frame for 3-way Loudspeakers

APPLICATION: Suspend and aim two or three full-range 3-way loudspeakers in an isometric array.

NOTE: Requires the loudspeakers to be fitted with Vertical Yokes or U-Brackets.

PREASSEMBLY:

Attach the Vertical Yokes or U-Brackets to the loudspeakers (see Vertical Yoke or U-Bracket instructions).

For 3-cabinet arrays: The frame bracket must be attached to the frame.

For 2-cabinet arrays for loudspeakers in vertical or horizontal orientation: The frame bracket is optional, but provides an extra forward lift point for the rigging. The loudspeakers should be symmetrically oriented and attached to the frame. The front grilles should form an arc.

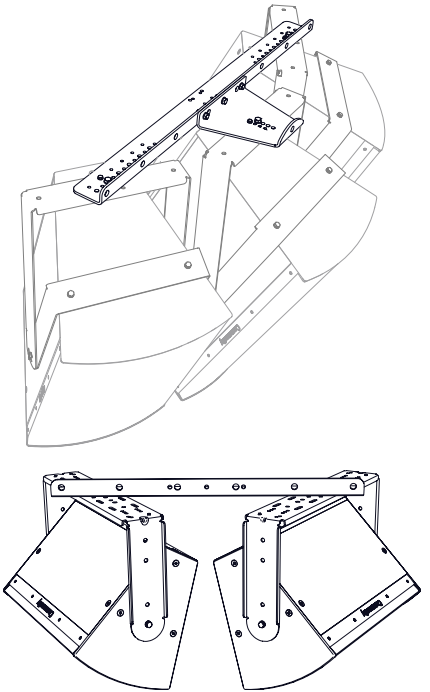

Parts:

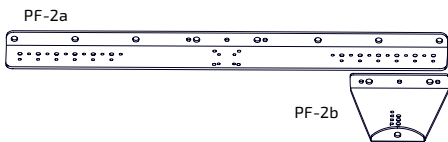

Allows up to 45° of pan/tilt within a 3-cabinet array of 3-way loudspeakers

PF-2a: Isometric Array Frame

PF-2b: Frame Bracket

Hardware:

Qty	Code	Description
3	HH8-2	8 x 25 mm Hex Hd Bolts
3	HN8	M8 Locknuts
6	HW8	8mm Flat Washers
6	HH12-3	12 x 30 mm Hex Hd Bolts
6	HN12	M12 Locknuts
12	HW12	12 mm Flat Washers

Note: There should not be any leftover hardware, unless only two (2) loudspeakers are mounted to the frame.

Kit Weight: 44.0 lb (20.0 kg)

MUST BE USED WITH: 2-3 Vertical yoke brackets or 2 U-Brackets horizontally.

Additional Configuration: A smaller fill loudspeaker or subwoofer can be added under the middle loudspeaker on a 3-cabinet array by using a DFS Downfill or DVS-BFR22 kit.

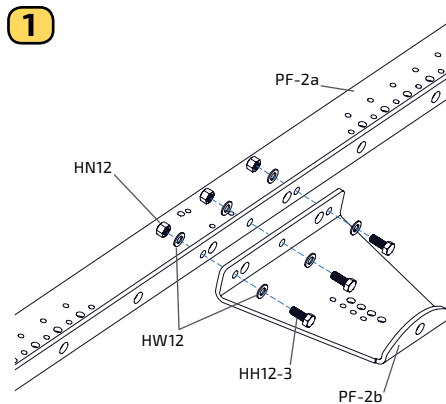

Figure 8-1. Attach bracket to array frame for 3-cabinet arrays or for extra stabilization on 2-cabinet arrays

2

Use 8mm hardware to set bracket pan angle
12mm hardware - Primary mounting point

Use 8mm hardware to set bracket pan angle
12mm hardware - Primary mounting point

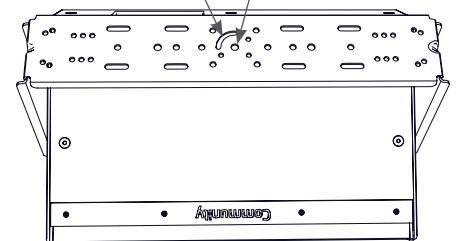
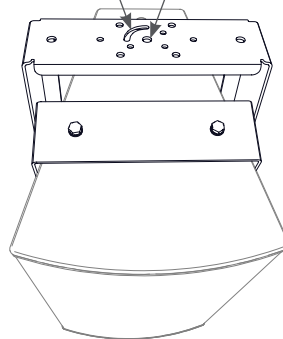

Figure 8-2. Yoke/U-Bracket mounting points

4 HORIZONTAL ARRAYS

IAF55 (continued)

3

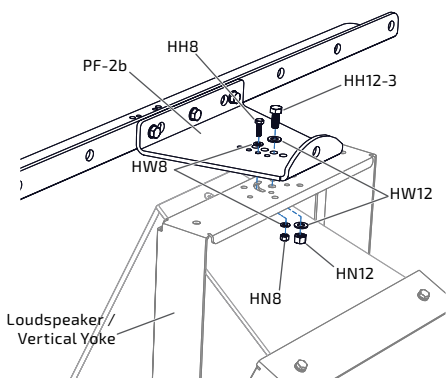

Figure 8-3. Mount center loudspeaker

4

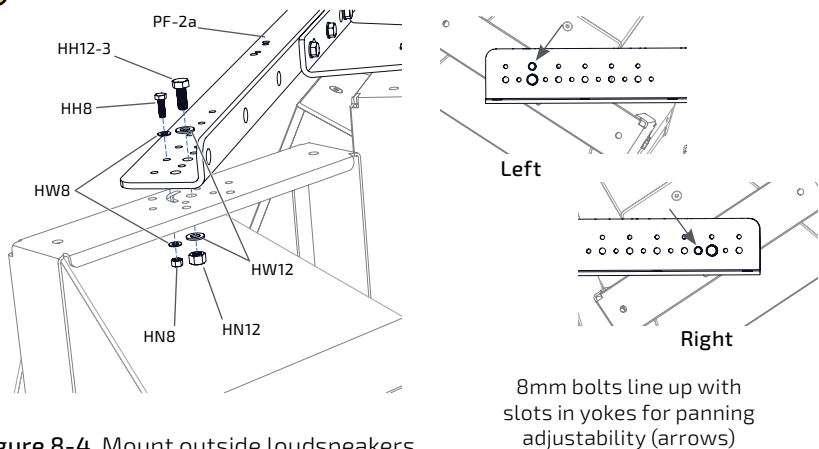
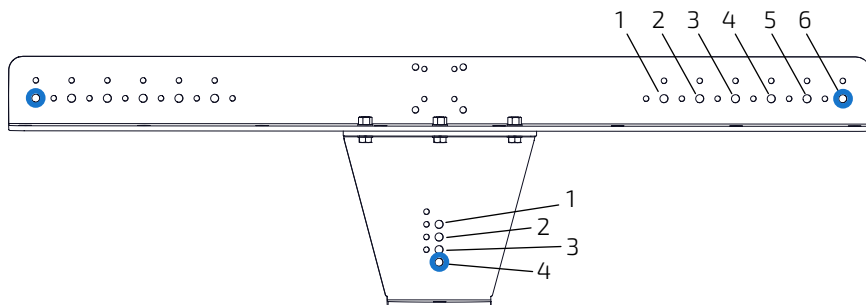

Figure 8-4. Mount outside loudspeakers



IMPORTANT

- Table at right shows the maximum symmetrical pan and tilt for a three cabinet array. Cabinets can be placed more closely but will have less rotation and/or tilt capabilities.
- 2-cabinet horizontal arrays should always mount to the outside (#6) holes on the frame for full rotation.
- The frame should be level when suspended and the pan and tilt is achieved by adjusting the yokes and the loudspeakers.
- BalancePoint™ Fly Rails can be added to the frame (attached right behind the middle bolt connection) to add subwoofers behind or additional lift or stabilization points.
- No more than three (3) full-range and two (2) subwoofers should be on any single connected configuration. Do not exceed the Safe Working Load (500 lbs) of the assembly. Loudspeaker weights are provided on the last page of this manual.



It is strongly recommended that a licensed and certified professional structural engineer approve the mounting. Severe injury and/or loss of life may occur if this product is improperly installed.

Degrees of **symmetrical** rotation and tilt for 3 (3-way) cabinets in vertical yokes
 ex. Cabinets mounted at holes 4/6 (heavy circles), provide a maximum 45° pan and 45° tilt for each cabinet.

Hole Position* (Bracket)	Frame					
	1	2	3	4	5	6
1	—	—	—	—	30°	40°
2	—	—	—	—	30°	40°
3	—	—	—	20°	35°	45°
4	—	—	—	20°	35°	45°

*Mounting positions as marked on the frame graphic

This chart is provided as a starting point. Tighter arrays using the 1-4 holes can be achieved for two cabinet arrays in portrait (vertical) orientation.

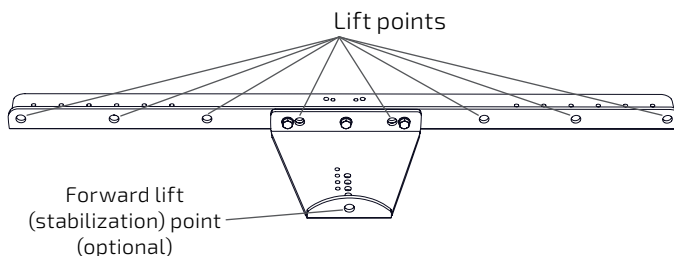

4 HORIZONTAL ARRAYS

HSB-BFR22 - Dual Horizontal Splay Kit for 2-way Loudspeakers

APPLICATION: Suspend and aim two full-range 2-way loudspeakers in a horizontal array (portrait orientation of the loudspeakers).

PREASSEMBLY:

Confirm that the 8mm hardware on the cabinet brackets is the correct position (See bolt pattern diagram below).

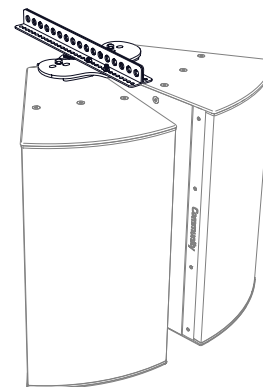

Parts:

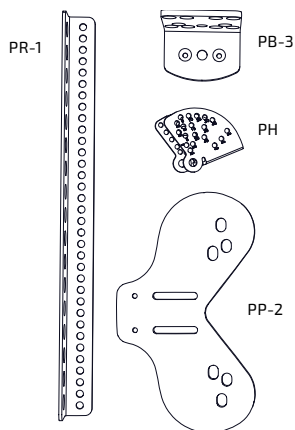

PR-1: 22" BalancePoint™ Fly Rails (2)
 PP-2: Splay Adapter Plate (1)
 PB-3: Cabinet Brackets (4)
 PH: Hinge Brackets (4=2 preassemblies)

Hardware:

Qty	Code	Description
4	HH6	6 x 25 mm Hex Hd Bolts
4	HN6	M6 Locknuts
8	HW6	6mm Flat Washers
2	HH8-2	8 x 25 mm Hex Hd Bolts
10	HF8-3	8 x 30 mm Flat Hd Bolts
12	HN8	M8 Locknuts
14	HW8	8mm Flat Washers
6	HF1-3	10 x 35 mm Flat Hd Bolts
2	HH1-5	10 x 55 mm Hex Hd Bolts
2	HH1-12	10 x 120 mm Hex Hd Bolts
2	HN1	M10 Locknuts
6	HW1	10 mm Flat Washers
2	HL1	10 mm Lock Washers

Some hardware listed above will be included in plate and hinge preassemblies.

Kit Weight: 25.0 lb (11.3 kg)

1

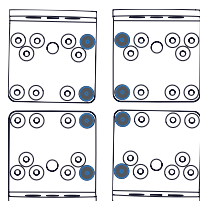

Figure 9-1a. After removing the applicable cabinet bolts, place cabinet brackets (with flat head bolts inserted) on the cabinets as shown

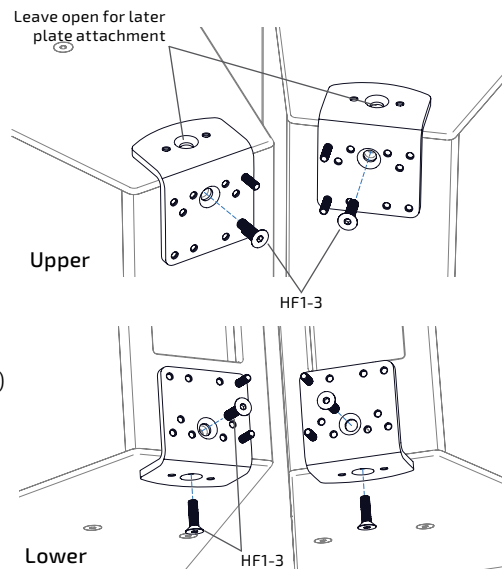

Figure 9-1b. Attach cabinet brackets to cabinets (3 connections per cabinet) - start all bolts before tightening any

2

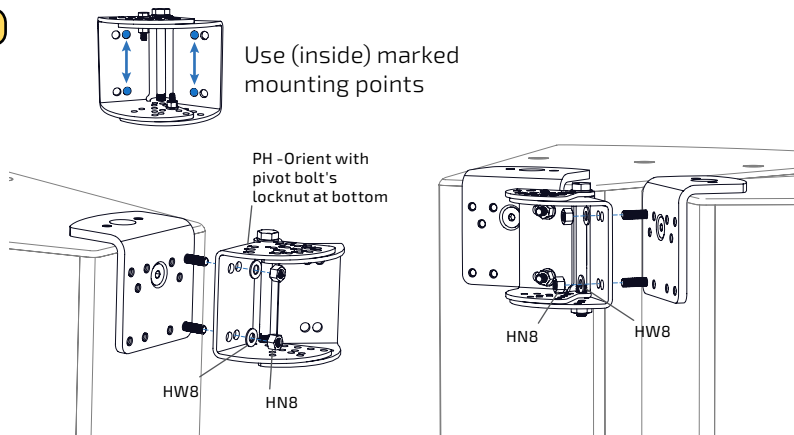

Figure 9-2. Stand the cabinets up, remove the 6mm hardware securing the angle, and attach the hinges to one cabinet and then the other (leave connections loose until both cabinets are connected)

4 HORIZONTAL ARRAYS

HSB-BFR22 (continued)

Best practices:

Orient hinges so that the nut securing the long bolt (hinge pivot) is at the bottom when mounted to a loudspeaker.

With the exception of the top connection, the 6mm hardware (securing the hinge angles), should also have the nuts at the bottom. This prevents bolts from falling out if the locknuts should loosen.

3

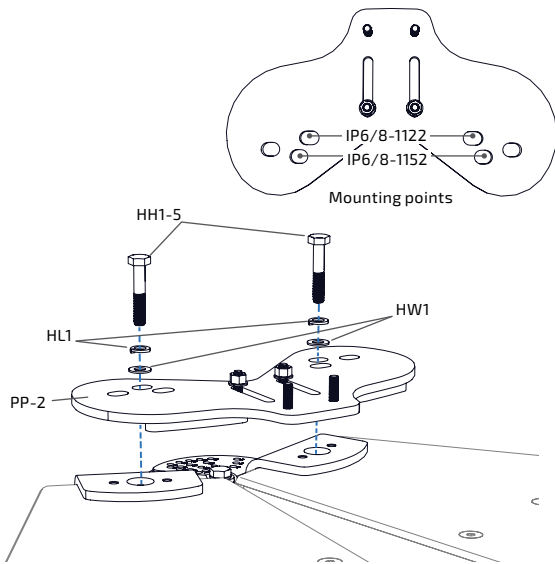

Figure 9-3. Attach splay plate - snug tighten bracket connections

4

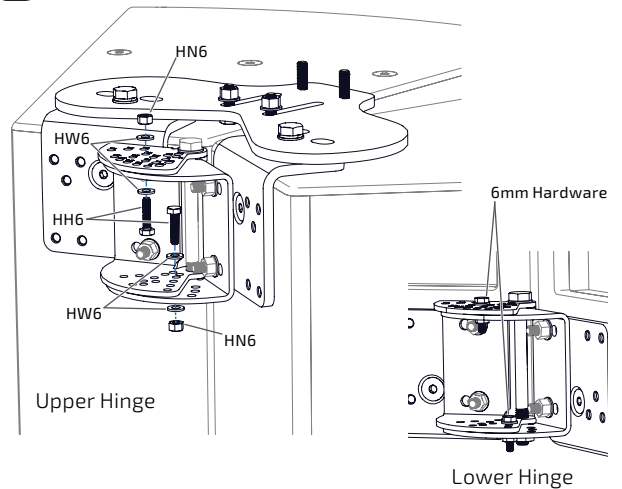

Figure 9-4. Secure angle on hinges by reinserting the 6mm hardware removed earlier - snug tighten

5

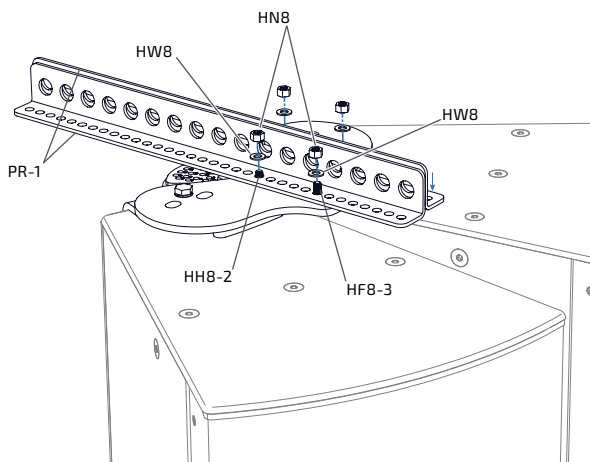

Figure 9-5. Remove the locknuts and flat washers from the hex head bolts in the adapter plate, move the bolts to the back of the slots, and attach the fly rails

6

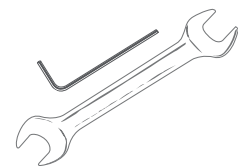

Figure 9-6. Fully tighten all connections

4 HORIZONTAL ARRAYS

HSB3-BFR22 - Dual Horizontal Splay Kit for 3-way Loudspeakers

APPLICATION: Suspend and aim two full-range 3-way loudspeakers in a horizontal array (portrait orientation of the loudspeakers).

PREASSEMBLY:

Confirm that the 8mm hardware on the cabinet brackets is the correct position (See bolt pattern diagram below).

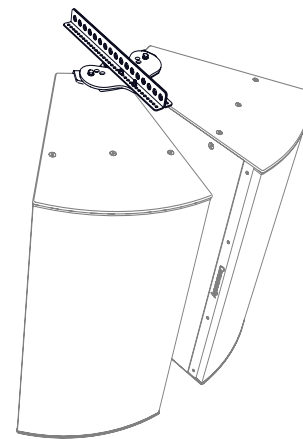

Parts:

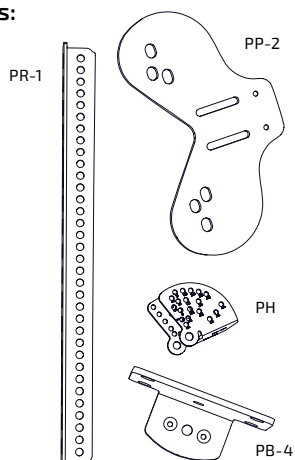

- PR-1: 22" BalancePoint® Fly Rails (2)
- PP-2: Splay Adapter Plate (1)
- PB-4: Cabinet Brackets (4)
- PH: Hinge Brackets (4=2 preassemblies)

Hardware:

Qty	Code	Description
4	HH6	6 x 25 mm Hex Hd Bolts
4	HN6	M6 Locknuts
8	HW6	6mm Flat Washers
2	HH8-2	8 x 25 mm Hex Hd Bolts
10	HF8-3	8 x 30 mm Flat Hd Bolts
12	HN8	M8 Locknuts
14	HW8	8mm Flat Washers
6	HF1-3	10 x 35 mm Flat Hd Bolts
2	HH1-5	10 x 55 mm Hex Hd Bolts
2	HH1-12	10 x 120 mm Hex Hd Bolts
2	HN1	M10 Locknuts
6	HW1	10 mm Flat Washers
2	HL1	10 mm Lock Washers

Some hardware listed above will be included in plate and hinge preassemblies.

Kit Weight: 31.0 lb (14.1 kg)

1

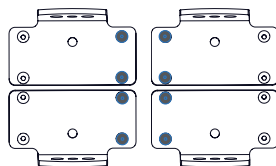

Figure 10-1a. After removing the applicable cabinet bolts, place cabinet brackets (with flat head bolts inserted) on the cabinets as shown

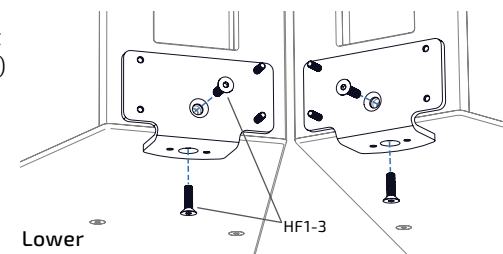
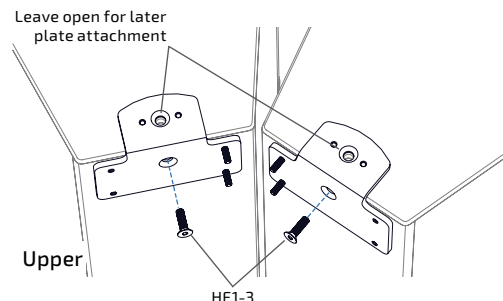
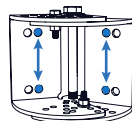

Figure 10-1b. Attach cabinet brackets to cabinets (3 connections per cabinet) - start all bolts before tightening any

2



Use (inside) marked mounting points

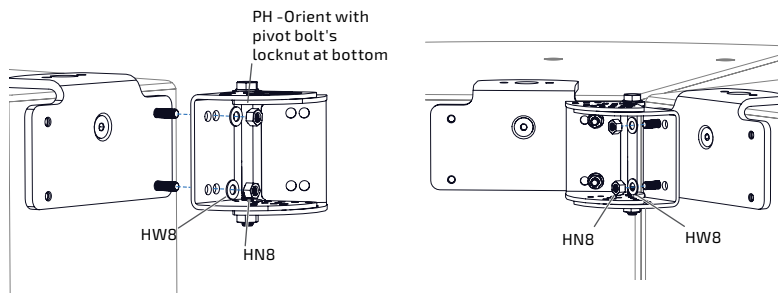

Figure 10-2. Stand the cabinets up, remove the 6mm hardware securing the angle, and attach the hinges to one cabinet and then the other (leave connections loose until both cabinets are connected)

4 HORIZONTAL ARRAYS

HSB3-BFR22 (continued)

Best practices:

Orient hinges so that the nut securing the long bolt (hinge pivot) is at the bottom when mounted to a loudspeaker.

With the exception of the top connection, the 6mm hardware (securing the hinge angles), should also have the nuts at the bottom. This prevents bolts from falling out if the locknuts should loosen.

3

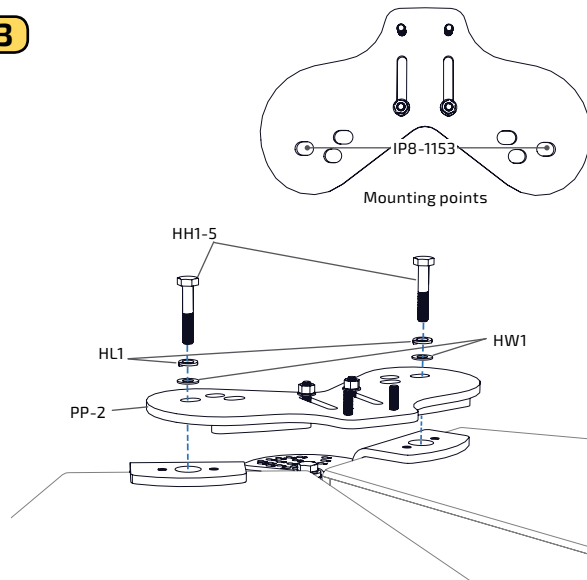

Figure 10-3. Attach splay plate
- snug tighten bracket connections

4

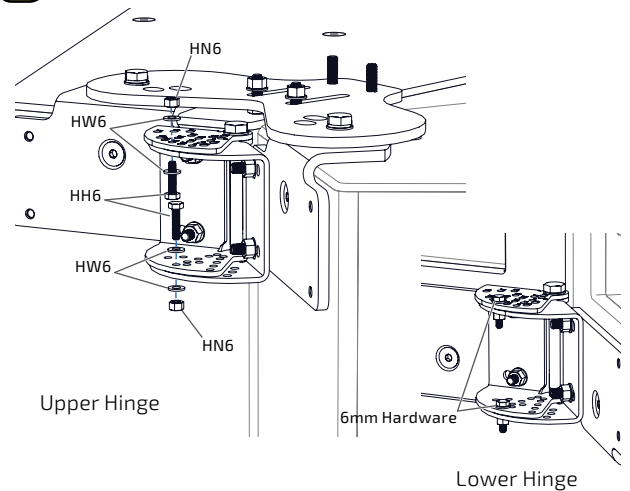

Figure 10-4. Secure angle on hinges by
reinserting the 6mm hardware removed earlier
- snug tighten connections

5

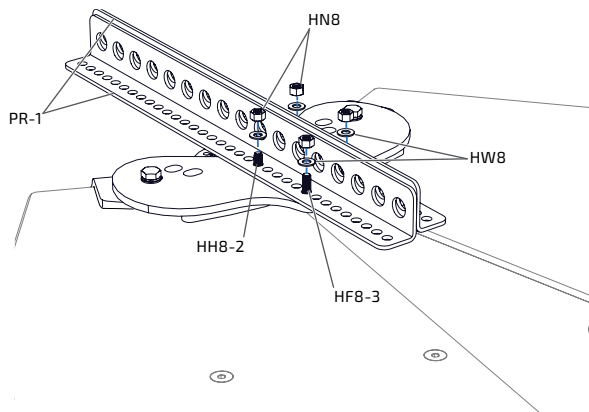

Figure 10-5. Remove the locknuts and flat washers from the hex head bolts in the adapter plate, move the bolts to the back of the slots, and attach the fly rails

6

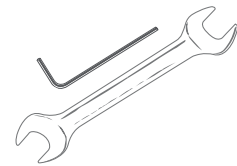

Figure 10-6. Fully tighten all connections

4 HORIZONTAL ARRAYS

HSB-SBR54 - Dual Horizontal Splay with Extension Kit (for subwoofer behind 2-way loudspeakers)

APPLICATION: Suspend and aim two full-range 2-way loudspeakers in a horizontal array (portrait orientation of the loudspeakers) with one or two subwoofers mounted behind on the 54" BalancePoint™ Fly Rails.

PREASSEMBLY:

Confirm that the 8mm hardware on the cabinet brackets is the correct position (See bolt pattern diagram below).

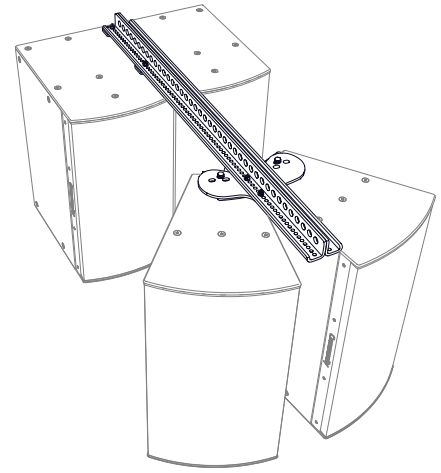

Parts:

- PR-3: 54" BalancePoint™ Fly Rails (2)
- PP-1: Universal Fly Rail Plates (2)
- PP-2: Splay Adapter Plate (1)
- PB-3: Cabinet Brackets (4)
- PH: Hinge Brackets (4=2 preassemblies)
- Gasket Material

Hardware:

Qty	Code	Description
4	HH6	6 x 25 mm Hex Hd Bolts
4	HN6	M6 Locknuts
8	HW6	6mm Flat Washers
2	HH8-3	8 x 30 mm Hex Hd Bolts
14	HF8-3	8 x 30 mm Flat Hd Bolts
16	HN8	M8 Locknuts
18	HW8	8mm Flat Washers
10	HF1-3	10 x 35 mm Flat Hd Bolts
2	HH1-5	10 x 55 mm Hex Hd Bolts
2	HH1-12	10 x 120 mm Hex Hd Bolts
2	HN1	M10 Locknuts
6	HW1	10 mm Flat Washers
2	HL1	10 mm Lock Washers

Some hardware listed above will be included in plate and hinge preassemblies.

Kit Weight: 32.0 lb (14.5 kg)

Purchase of a Tight Pack kit (TPK) is suggested when hanging dual subwoofers. Follow those instructions to connect the bottom of the subwoofers with two (2) additional mounting plates.

1

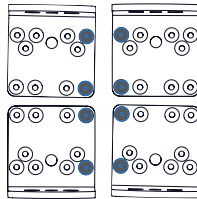

Figure 11-1a. After removing the applicable cabinet bolts, place cabinet brackets (with flat head bolts inserted) on the cabinets as shown

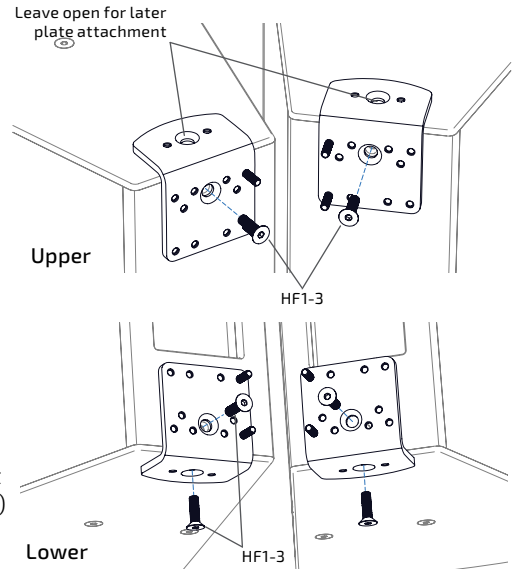

Figure 11-1b. Attach cabinet brackets to cabinets (3 connections per cabinet) - start all bolts before tightening any

2

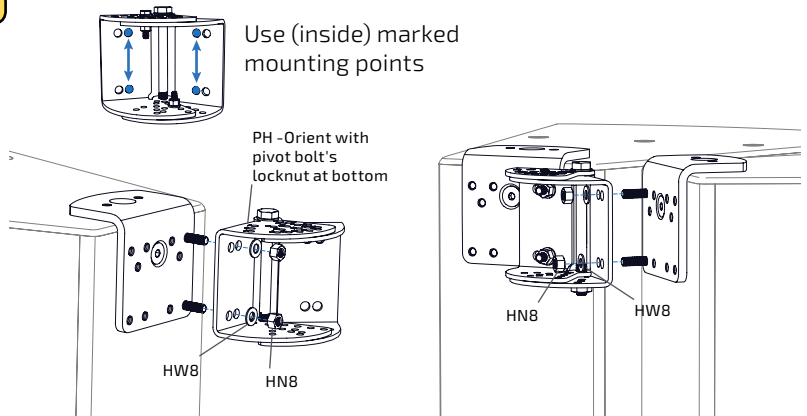

Figure 11-2. Stand the cabinets up, remove the 6mm hardware securing the angle, and attach the hinges to one cabinet and then the other (leave connections loose until both cabinets are connected)

4 HORIZONTAL ARRAYS

HSB-SBR54 (continued)

Best practices:

Orient hinges so that the nut securing the long bolt (hinge pivot) is at the bottom when mounted to a loudspeaker.

With the exception of the top connection, the 6mm hardware (securing the hinge angles), should also have the nuts at the bottom. This prevents bolts from falling out if the locknuts should loosen.

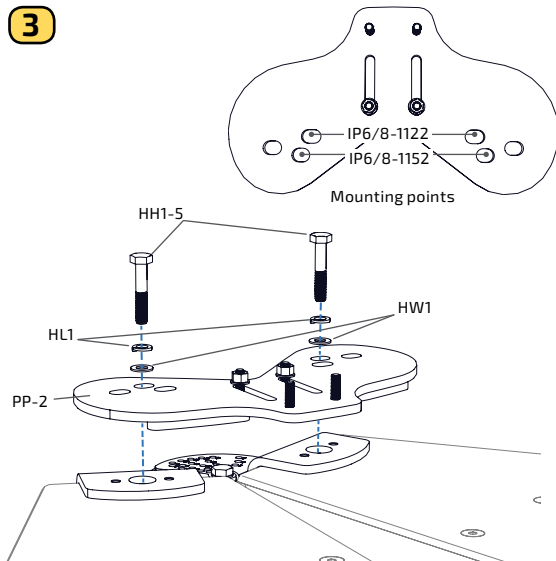

Figure 11-3. Attach splay plate - snug tighten bracket connections

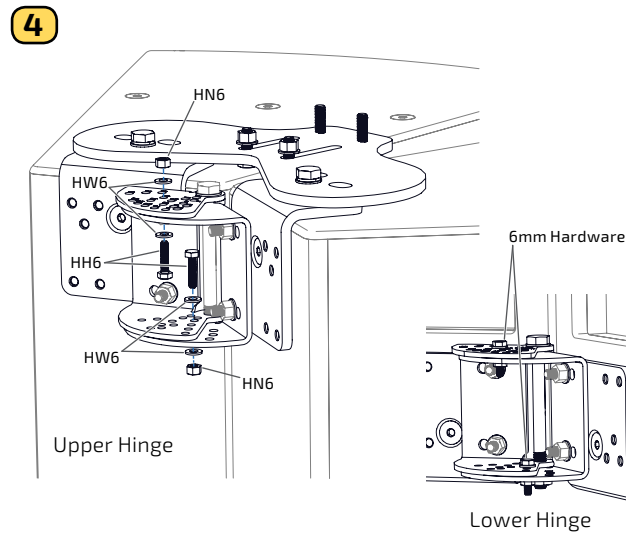

Figure 11-4. Secure angle on hinges by reinserting the 6mm hardware removed earlier - snug tighten connections

5 Single Subwoofer

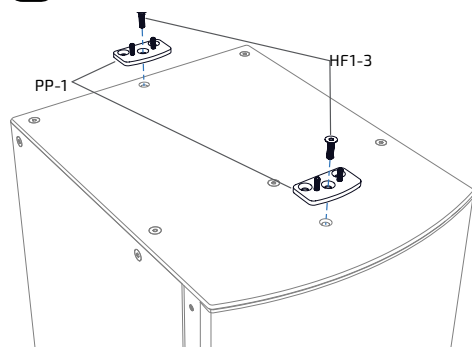

Figure 11-5a. Attach two (2) PP-1 to the front and rear connection points on the subwoofer

5 Dual Subwoofers

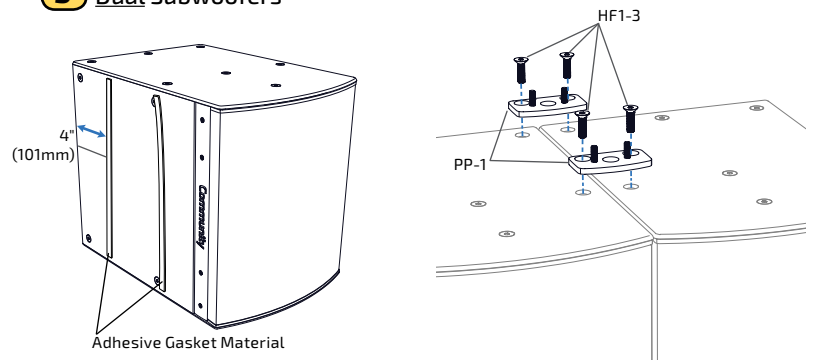

Figure 11-5b. Cut and adhere (2) strips of gasket to the side of one subwoofer (spanning the height and spaced equidistant). With the gasket sandwiched between the cabinets, attach (2) PP-1 and fully tighten connections

4 HORIZONTAL ARRAYS

HSB-SBR54 (continued)

Best practices:

Leave at least 6" (152mm) between the front of the subwoofer and the back of the splayed full-range loudspeakers. The subwoofer(s) can be placed at the end of the fly rail.

CAUTION: Installation of I SERIES loudspeakers should only be performed by trained and qualified personnel. It is strongly recommended that a licensed and certified professional structural engineer approve the mounting. Severe injury and/or loss of life may occur if this product is improperly installed.

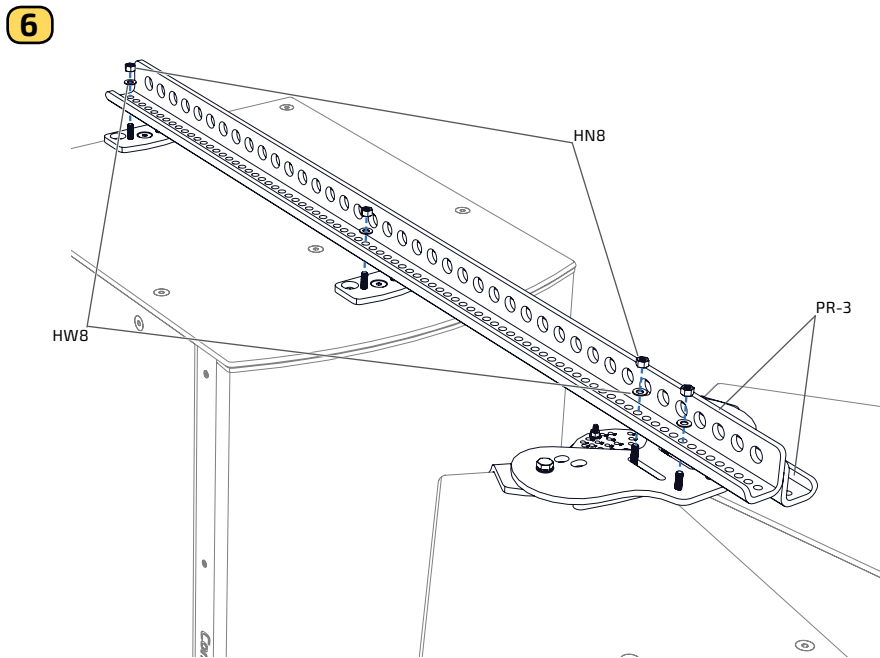

Figure 11-6. Remove the locknuts and flat washers from the hex head bolts in the adapter plate, move the bolts to the back of the slots, and attach both rails to the universal mounting plates and splay adapter plate (*single subwoofer shown*).

7

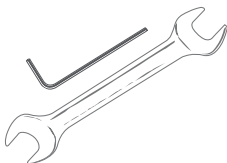

Figure 11-7. Fully tighten all connections



IMPORTANT: Attach a safety cable to one of the unused mounting points. Safety cables must be secured to a suitable load-bearing point separate from the loudspeaker mounting point, with as little slack as possible, oriented to minimize dynamic swinging of the load, so as not to develop undue shock or kinetic force if the loudspeaker mount were to fail. Safety cables and hardware are not included. Please consult a structural engineer for the appropriate cable and hardware for the load and application.

4 HORIZONTAL ARRAYS

HSB3-SBR54 - Dual Horizontal Splay with Extension Kit (for subwoofer behind 3-way loudspeakers)

APPLICATION: Suspend and aim two full-range 3-way loudspeakers in a horizontal array (portrait orientation of the loudspeakers) with one or two subwoofers mounted behind on the 54" BalancePoint™ Fly Rails.

PREASSEMBLY:

Confirm that the 8mm hardware on the cabinet brackets is the correct position (See bolt pattern diagram below).

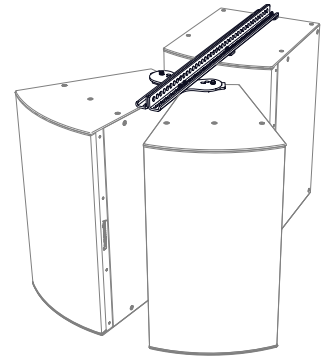

Parts:

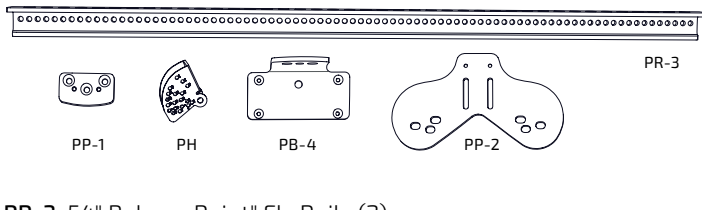

PR-3: 54" BalancePoint™ Fly Rails (2)
 PP-1: Universal Fly Rail Plates (2)
 PP-2: Splay Adapter Plate (1)
 PB-4: Cabinet Brackets (4)
 PH: Hinge Brackets (4=2 preassemblies)
 Gasket Material

Hardware:

Qty	Code	Description
4	HH6	6 x 25 mm Hex Hd Bolts
4	HN6	M6 Locknuts
8	HW6	6mm Flat Washers
2	HH8-3	8 x 30 mm Hex Hd Bolts
14	HF8-3	8 x 30 mm Flat Hd Bolts
16	HN8	M8 Locknuts
18	HW8	8mm Flat Washers
10	HF1-3	10 x 35 mm Flat Hd Bolts
2	HH1-5	10 x 55 mm Hex Hd Bolts
2	HH1-12	10 x 120 mm Hex Hd Bolts
2	HN1	M10 Locknuts
6	HW1	10 mm Flat Washers
2	HL1	10 mm Lock Washers

Some hardware listed above will be included in plate and hinge preassemblies.

Kit Weight: 42.0 lb (19.1 kg)

Purchase of a Tight Pack kit (TPK) is suggested when hanging dual subwoofers. Follow those instructions to connect the bottom of the subwoofers with two (2) additional mounting plates.

1

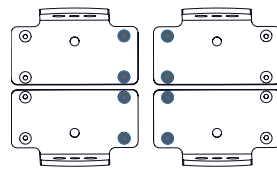

Figure 12-1a. After removing the applicable cabinet bolts, place cabinet brackets (with flat head bolts inserted) on the cabinets as shown

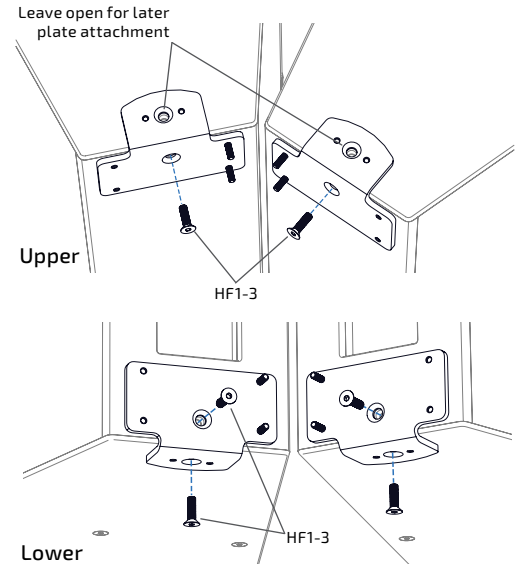

Figure 12-1b. Attach cabinet brackets to cabinets (3 connections per cabinet) - start all bolts before tightening any

2

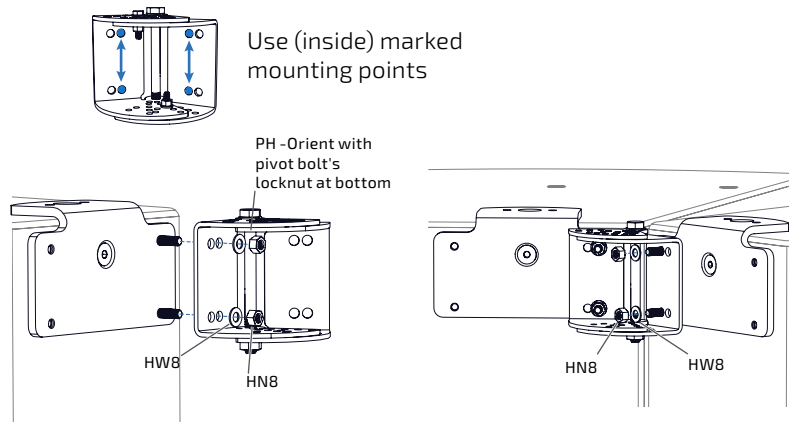

Figure 12-2. Stand the cabinets up, remove the 6mm hardware securing the angle, and attach the hinges to one cabinet and then the other (leave connections loose until both cabinets are connected)

4 HORIZONTAL ARRAYS

HSB3-SBR54 (continued)

Best practices:

Orient hinges so that the nut securing the long bolt (hinge pivot) is at the bottom when mounted to a loudspeaker.

With the exception of the top connection, the 6mm hardware (securing the hinge angles), should also have the nuts at the bottom. This prevents bolts from falling out if the locknuts should loosen.

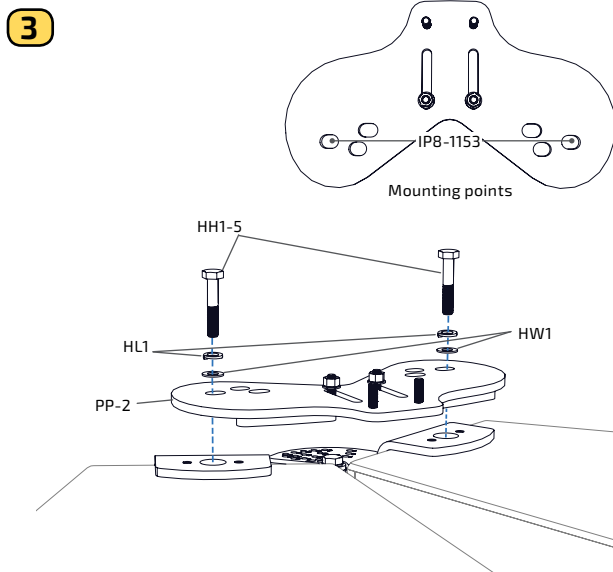

Figure 12-3. Attach splay plate
- snug tighten bracket connections

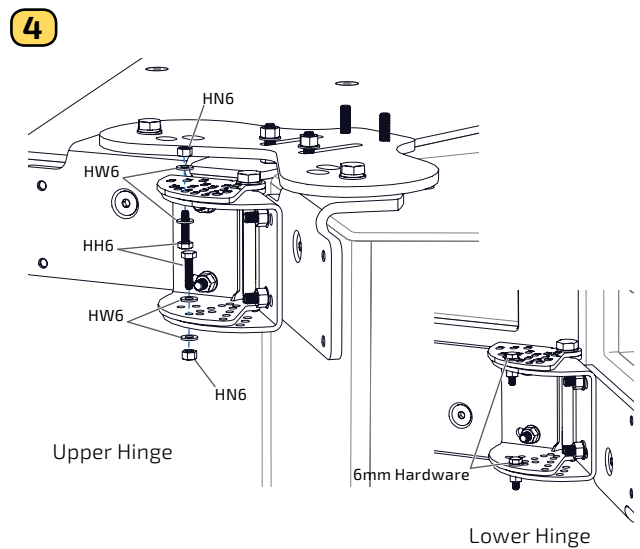

Figure 12-4. Secure angle on hinges by
reinserting the 6mm hardware removed earlier
- snug tighten connections

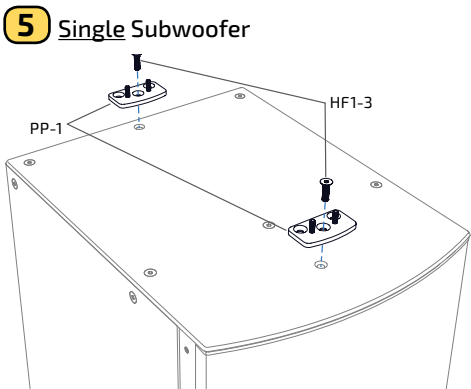

Figure 12-5a. Attach two (2) PP-1
to the front and rear connection
points on the subwoofer

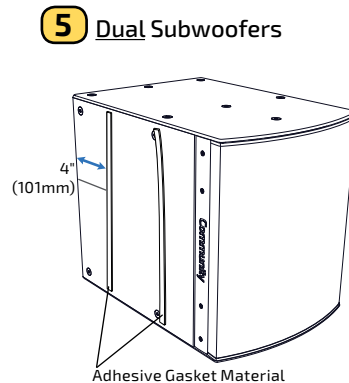

Figure 12-5b. Cut and adhere (2) strips of gasket to the
side of one subwoofer (spanning the height and spaced
equidistant). With the gasket sandwiched between the
cabinets, attach (2) PP-1 and fully tighten connections

4 HORIZONTAL ARRAYS

HSB3-SBR54 (continued)

Best practices:

Leave at least 6" (152mm) between the front of the subwoofer and the back of the splayed full-range loudspeakers. The subwoofer(s) can be placed at the end of the fly rail.



CAUTION: Installation of I SERIES loudspeakers should only be performed by trained and qualified personnel. It is strongly recommended that a licensed and certified professional structural engineer approve the mounting. Severe injury and/or loss of life may occur if this product is improperly installed.

6

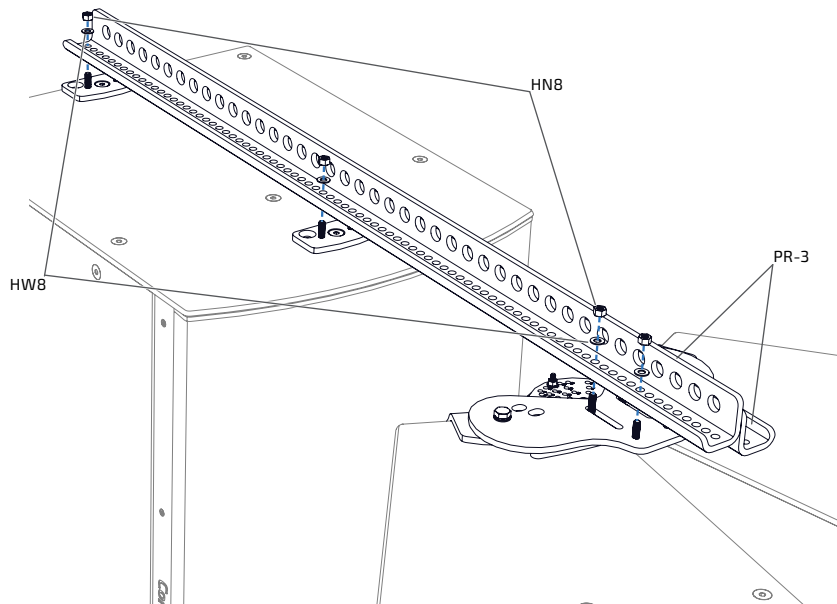

Figure 12-6. Remove the locknuts and flat washers from the hex head bolts in the adapter plate, move the bolts to the back of the slots, and attach both rails to the universal mounting plates and splay adapter plate (single subwoofer shown).

7

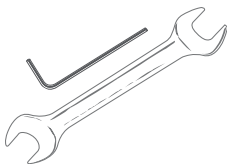

Figure 12-7. Fully tighten all connections



IMPORTANT: Attach a safety cable to one of the unused mounting points. Safety cables must be secured to a suitable load-bearing point separate from the loudspeaker mounting point, with as little slack as possible, oriented to minimize dynamic swinging of the load, so as not to develop undue shock or kinetic force if the loudspeaker mount were to fail. Safety cables and hardware are not included. Please consult a structural engineer for the appropriate cable and hardware for the load and application.

4 HORIZONTAL ARRAYS

HAB-BFR38 - Dual Horizontal Array Kit for 2-way Models (for 12"/15" subwoofer between)

APPLICATION: Suspend and array two full-range 2-way loudspeakers with one subwoofer mounted between in a horizontal array (portrait orientation of the loudspeakers) with 38" BalancePoint™ Fly Rails.

ASSEMBLY:

Determine the angle that the loudspeakers should be arrayed. Set the loudspeakers on a protected surface in the proper arrangement.

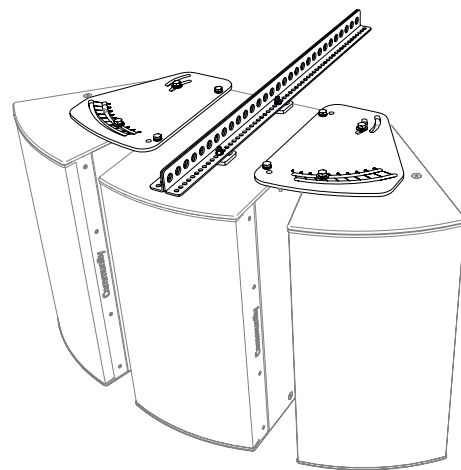

Parts:

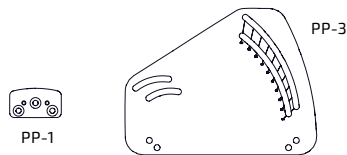

- PR-2: 38" BalancePoint™ Fly Rails (2)
- PP-1: Universal Mounting Plates (2)
- PP-3: Array Plates (2)

Hardware:

Qty	Code	Description
4	HF8-3	8 x 30 mm Flat Hd Bolts
4	HW8	8mm Flat Washers
4	HN8	M8 Locknuts
8	HH1-4	10 x 40 mm Hex Hd Bolts
2	HF1-3	10 x 35 mm Flat Hd Bolts
8	HW1	10 mm Flat Washers
8	HL1	10 mm Lock Washers

Notes:

Use this kit for 12/15" subwoofers connected to IP6/IP8-1122 or IP6/IP8-1152 models.
The full-range cabinets should be the same size model, but do not need to be the same height as the subwoofer.
Some 8mm hardware listed above will be included in plate preassemblies.

Kit Weight: 40.0 lb (18.1 kg)

1

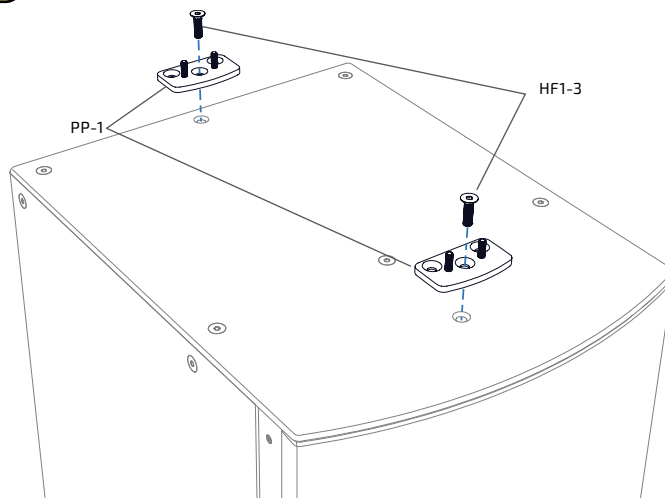
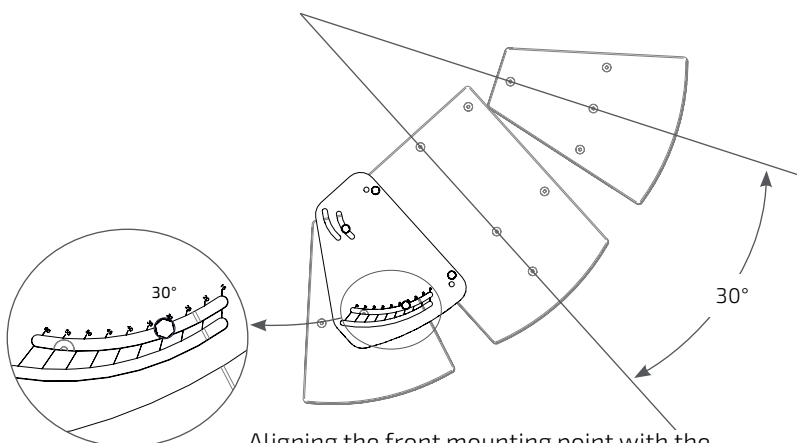

Figure 13 -1. Attach universal mounting plates to subwoofer



Aligning the front mounting point with the degree marking on the plate will give you the array angle (between centers)

4 HORIZONTAL ARRAYS

HAB-BFR38 (continued)



IMPORTANT: The array angle for the full-range cabinets should be the same. If it isn't, the center of balance will be affected and adjustments will need to be made to the suspension points.

Best Practices:

For best aesthetics, the BalancePoint™ Fly Rails should not extend beyond the front of the loudspeakers.

2

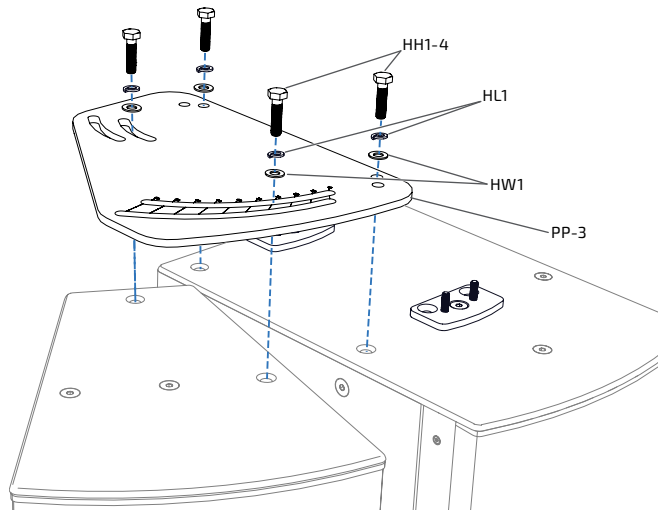
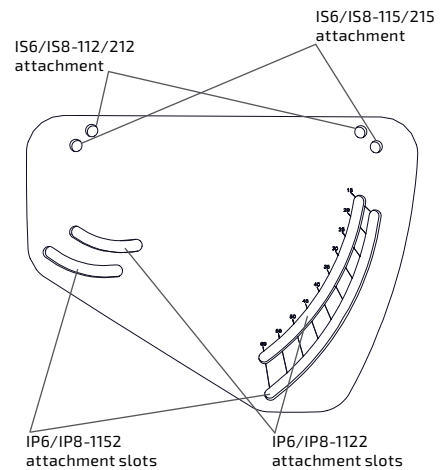

Figure 13-2. Attach array plates to the cabinets - see detail at right for definition of attachment points for PP-3 plate
Leave connections to full-range cabinets loose until angle is determined



3

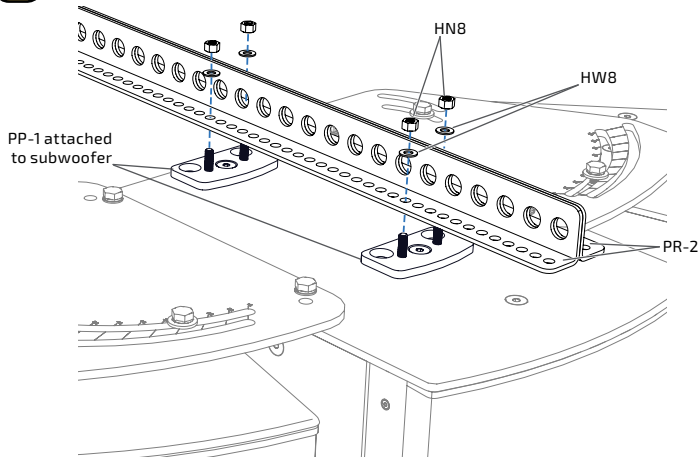

Figure 13-3. Attach fly rails to subwoofer

4

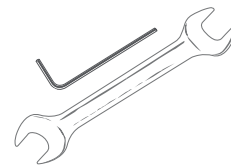

Figure 13-4. Fully tighten all connections

4 HORIZONTAL ARRAYS

HAB3-BFR38 - Dual Horizontal Array Kit for 3-way Models (for 15"/18" subwoofer between a pair of IP8-1153s or IP8-0002s)

APPLICATION: Suspend and array two full-range 3-way loudspeakers (or a pair of IP8-0002 mid-high loudspeakers) with one subwoofer mounted between in a horizontal array (portrait orientation of the loudspeakers) with 38" BalancePoint™ Fly Rails.

ASSEMBLY: Determine the angle that the loudspeakers should be arrayed. Set the loudspeakers on a protected surface in the proper arrangement.

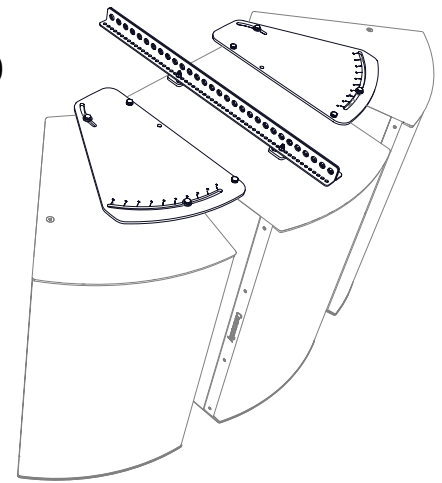

Parts:

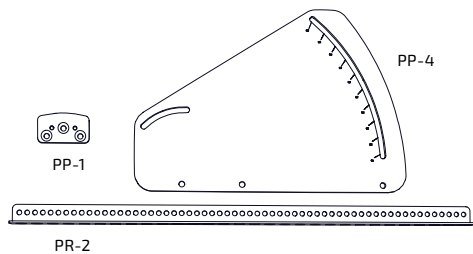

PR-2: 38" BalancePoint™ Fly Rails (2)
PP-1: Universal Mounting Plates (2)
PP-4: Array Plates (2)

Hardware:

Qty	Code	Description
4	HF8-3	8 x 30 mm Flat Hd Bolts
4	HW8	8mm Flat Washers
4	HN8	M8 Locknuts
8	HH1-4	10 x 40 mm Hex Hd Bolts
2	HF1-3	10 x 35 mm Flat Hd Bolts
8	HW1	10 mm Flat Washers
8	HL1	10 mm Lock Washers

Notes:

Use for 15"/18" subwoofers and IP8-0002 or IP8-1153 models.

The full-range cabinets should be the same size model, but do not need to be the same height as the subwoofer.

Some 8mm hardware listed above will be included in plate preassemblies.

Kit Weight: 58.0 lb (26.3 kg)

1

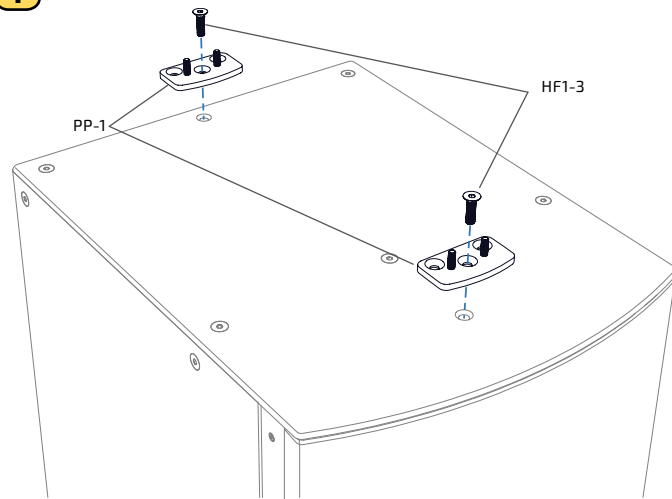

Figure 14-1. Attach universal mounting plates to subwoofer

4 HORIZONTAL ARRAYS

HAB3-BFR38 (continued)



IMPORTANT: The array angle for the full-range/mid-high cabinets should be the same. If it isn't, the center of balance will be affected and adjustments will need to be made to the suspension points.

Best Practices:

For best aesthetics, the BalancePoint™ Fly Rails should not extend beyond the front of the loudspeakers.

2

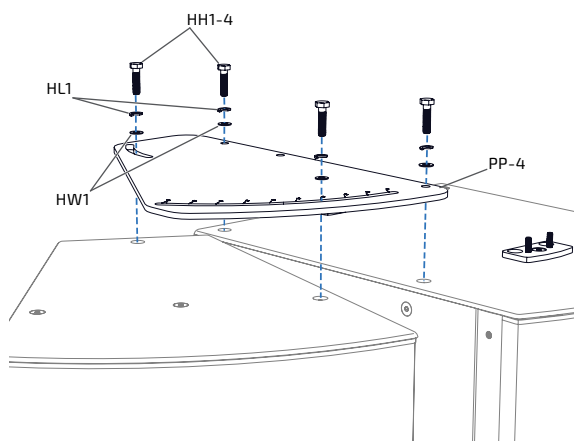
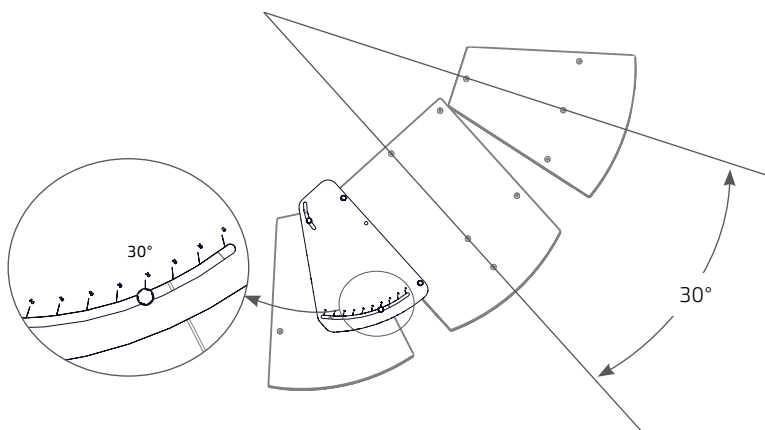

Figure 14 -2. Attach array plates to the cabinets
Leave connections to outside cabinets loose until angle is determined



Aligning the front mounting point with the degree marking on the plate will give you the array angle (between centers)

3

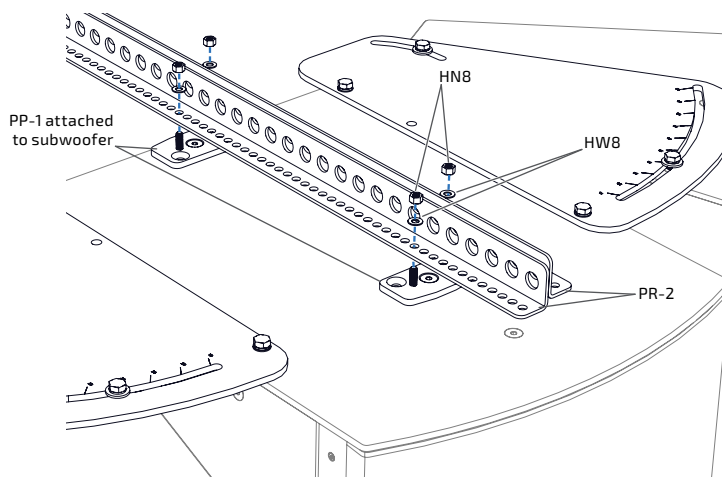

Figure 14-3. Attach fly rails to subwoofer

4

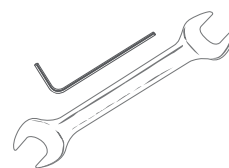

Figure 14-4. Fully tighten all connections

5 VERTICAL ARRAYS

VS-BFR22 - Dual Vertical Splay Kit for 2-way Models (Vertically array two 2-way loudspeakers)

APPLICATION: Suspend and vertically array two full-range 2-way loudspeakers (landscape orientation of the loudspeakers) with BalancePoint™ Fly Rails.

PREASSEMBLY:

Confirm that the 8mm hardware on the cabinet brackets is the correct position (See bolt pattern diagram below). It will differ for the top cabinet brackets depending whether you are using 1122 or 1152 models. You will need to move the 4 flat head bolts to the outside holes if you are mounting to IP6/8-1152 cabinets.

ASSEMBLY:

The array can be assembled from the top down by attaching the brackets and rails to what will be the top cabinet and then suspending it and adding the lower cabinet, or the full unit can be assembled on the floor (on its side on a protected surface) and then lifted/flown.

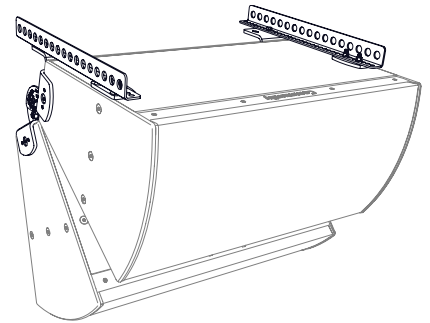

Parts:

PR-1: 22" BalancePoint™ Fly Rails (2)
 PP-1: Universal Mounting Plates (2)
 PB-2: Dual L Brackets (2)
 PB-3: Cabinet Brackets (4)
 PH: Hinge Brackets (4=2 preassemblies)

Hardware:

Qty	Code	Description
4	HH6	6 x 25 mm Hex Hd Bolts
4	HN6	M6 Locknuts
8	HW6	6mm Flat Washers
2	HH8-2	8 x 25 mm Hex Hd Bolts
16	HF8-3	8 x 30 mm Flat Hd Bolts
20	HW8	8mm Flat Washers
18	HN8	M8 Locknuts
2	HH1-12	10 x 120 mm Hex Hd Bolts
10	HF1-3	10 x 35 mm Flat Hd Bolts
4	HW1	10 mm Flat Washers
2	HN1	M10 Locknuts

Some hardware listed above will be included in plate and hinge preassemblies.

Note: One additional cabinet may be added to the array by using one HVS kit.

Kit Weight: 27.0 lb (12.2 kg)

1 IP6/8-1122

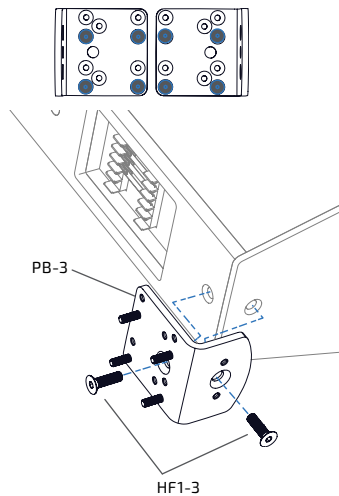

1 IP6/8-1152

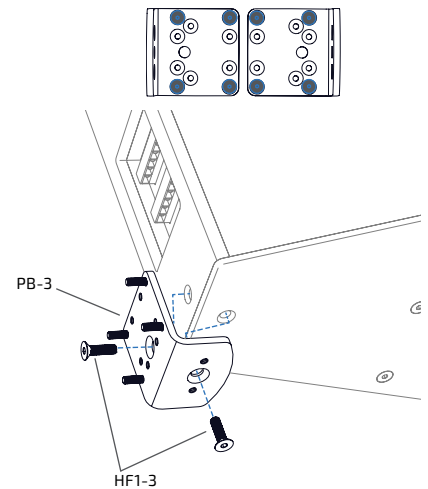
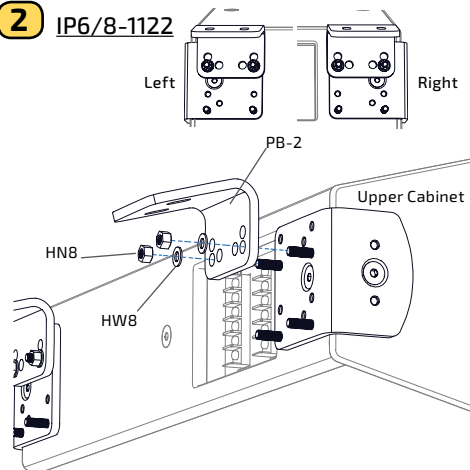

Figure 15-1. After removing the applicable cabinet bolts, place upper cabinet brackets (with flat head bolts inserted) on the cabinets as shown - note position of top bolts

2 IP6/8-1122



2 IP6/8-1152

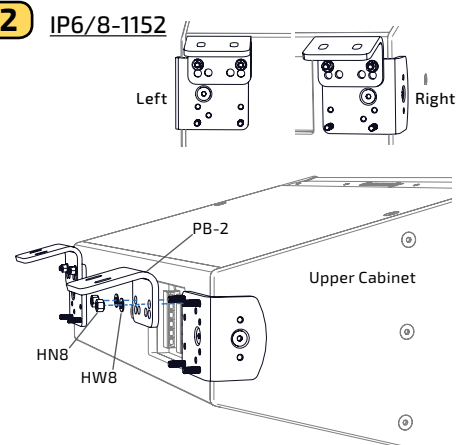

Figure 15-2. Attach the L brackets to the cabinet brackets - note which holes in the L bracket to use

5 VERTICAL ARRAYS

VSB-BFR22 (continued)

Best Practices:

For best aesthetics, the BalancePoint™ Fly Rails should not extend beyond the front of the loudspeakers.

Attach safety cable(s) to the loudspeakers and/or assembly as advised by a registered structural engineer.



Important: Cabinet and rail connections should be fully tightened (as you proceed) before suspending each component.

3

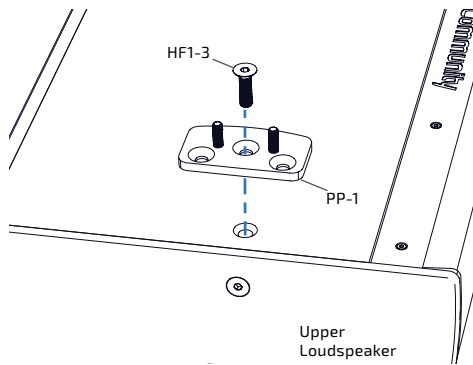

Figure 15-3. Attach PP-1 to enclosure with outside edges parallel and fully tighten

4

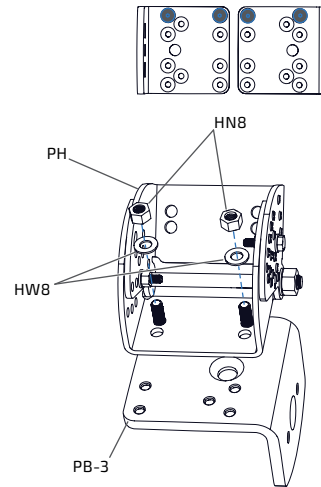

Figure 15-4. Attach hinges (2) to remaining cabinet brackets - use the holes closest to the hinge pivot

5

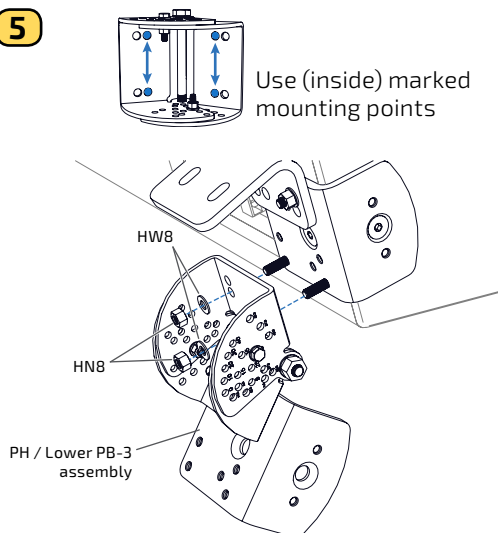

Figure 15-5. Attach hinge/ bracket assembly to the upper cabinet - use the holes closest to the hinge pivot

6

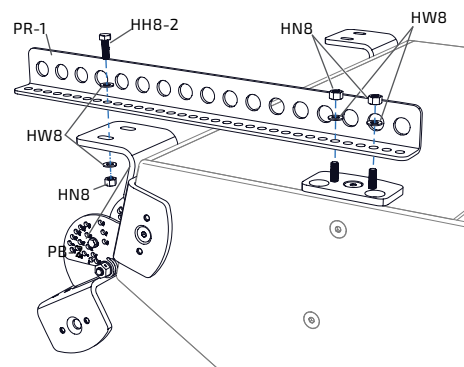

Figure 15-6. Attach rails to upper cabinet - position rail with most of the excess in the rear Fully tighten connections to the fly rails

5 VERTICAL ARRAYS

VSB-BFR22 (continued)

7

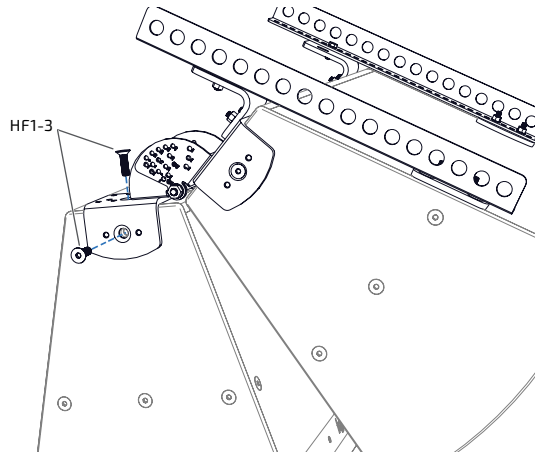
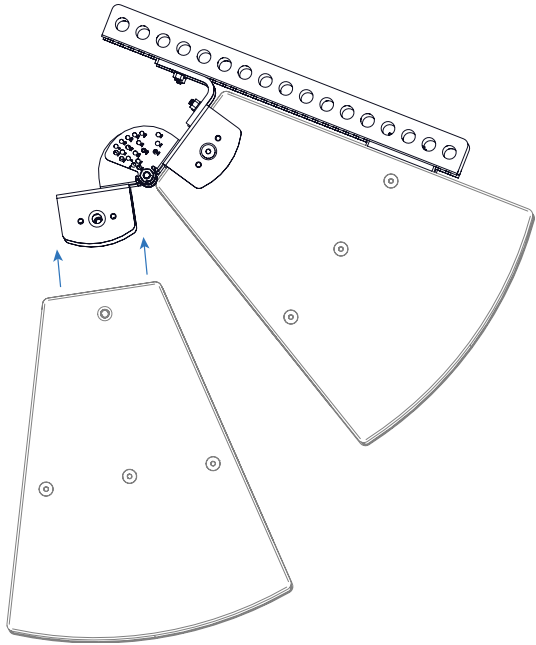

Figure 15-7. Remove the 6mm hardware and lift the lower cabinet up to the upper assembly. Attach lower cabinet to the hinge/bracket. Start all bolts before fully tightening them.

8

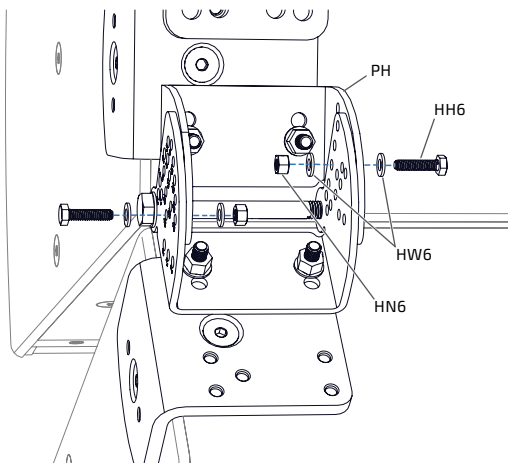

Figure 15-8. Adjust hinge to desired angle and reinsert the 6mm hardware. Snug tighten the 6mm connections until desired angle is confirmed, then fully tighten.

9

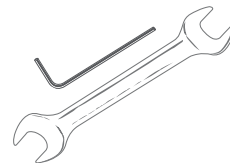
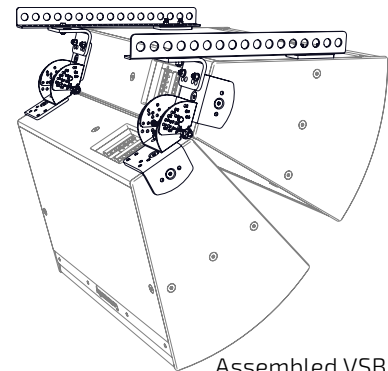

Figure 15-9. Fully tighten all connections.



Assembled VSB-BFR22

5 VERTICAL ARRAYS

VS3-BFR22 - Dual Vertical Splay Kit for 3-way Models (Vertically array two 3-way loudspeakers)

APPLICATION: Suspend and vertically array two full-range 3-way loudspeakers (landscape orientation of the loudspeakers) with BalancePoint™ Fly Rails.

PREASSEMBLY:

Confirm that the 8mm hardware on the cabinet brackets is the correct position (See bolt pattern diagram below).

ASSEMBLY:

The array should be assembled from the top down by attaching the brackets and rails to what will be the top cabinet and then suspending it and adding the lower cabinet.

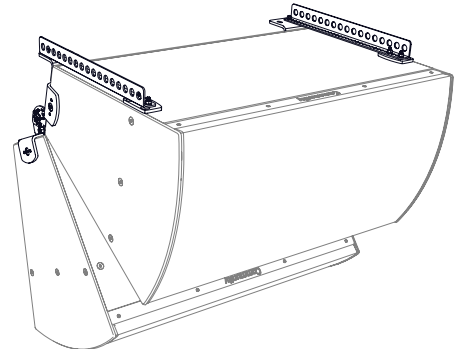

Parts:

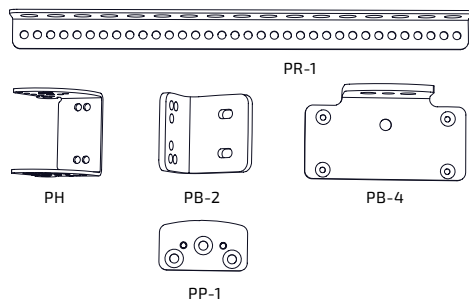

- PR-1: 22" BalancePoint™ Fly Rails (2)
- PP-1: Universal Mounting Plates (2)
- PB-2: Dual L Brackets (2)
- PB-4: Cabinet Brackets (4)
- PH: Hinge Brackets (4=2 preassemblies)

Hardware:

Qty	Code	Description
4	HH6	6 x 25 mm Hex Hd Bolts
4	HN6	M6 Locknuts
8	HW6	6mm Flat Washers
2	HH8-2	8 x 25 mm Hex Hd Bolts
16	HF8-3	8 x 30 mm Flat Hd Bolts
20	HW8	8mm Flat Washers
18	HN8	M8 Locknuts
2	HH1-12	10 x 120 mm Hex Hd Bolts
10	HF1-3	10 x 35 mm Flat Hd Bolts
4	HW1	10 mm Flat Washers
2	HN1	M10 Locknuts

Note: One additional cabinet may be added to the array by using one HVS3 kit. Some hardware listed above will be included in plate and hinge preassemblies.

Kit Weight: 32.0 lb (14.5 kg)

1

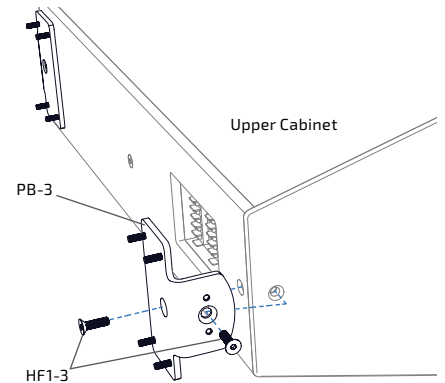
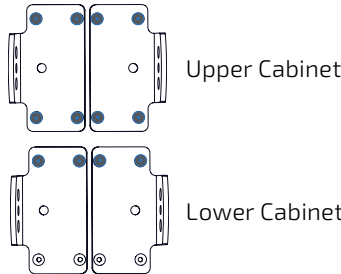

Figure 16-1. After removing the applicable cabinet bolts, place upper cabinet brackets (with flat head bolts inserted) on the cabinets as shown

2

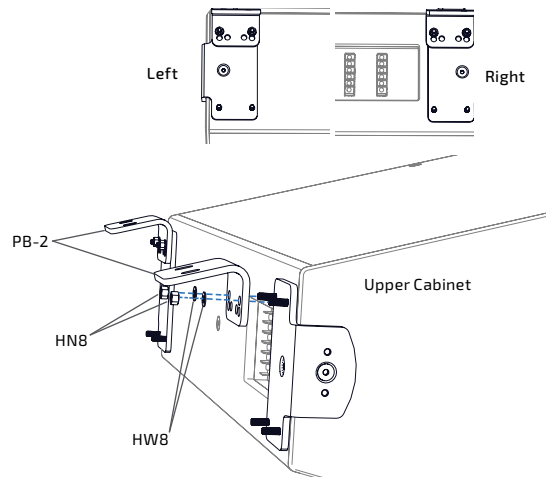

Figure 16-2. Attach the L brackets to the cabinet brackets - note which holes to use in the L bracket

5 VERTICAL ARRAYS

VS3-BFR22 (continued)

Best Practices:

For best aesthetics, the BalancePoint™ Fly Rails should not extend beyond the front of the loudspeakers.

Attach safety cable(s) to the loudspeakers and/or assembly as advised by a registered structural engineer.



Important: Cabinet and rail connections should be fully tightened (as you proceed) before suspending each component.

3

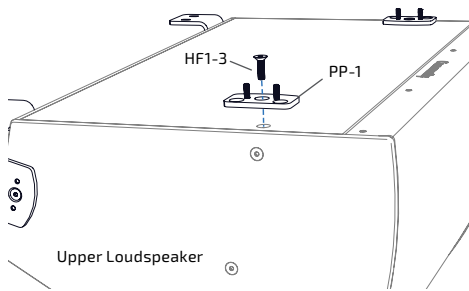

Figure 16-3. Attach PP-1 to enclosure - with outside edges parallel and fully tighten

4

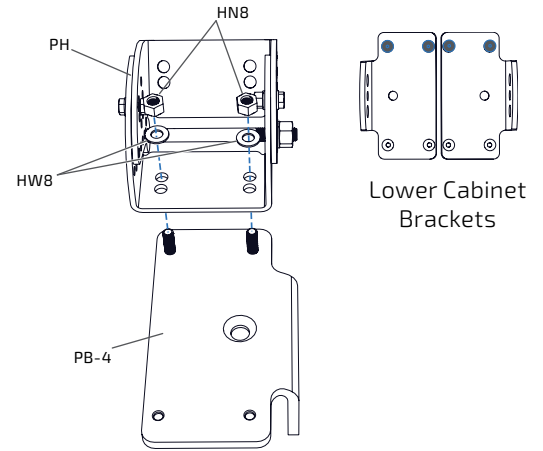
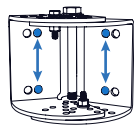

Figure 16-4. Attach hinges (2) to remaining cabinet brackets - use the holes closest to the hinge pivot

5



Use (inside) marked mounting points

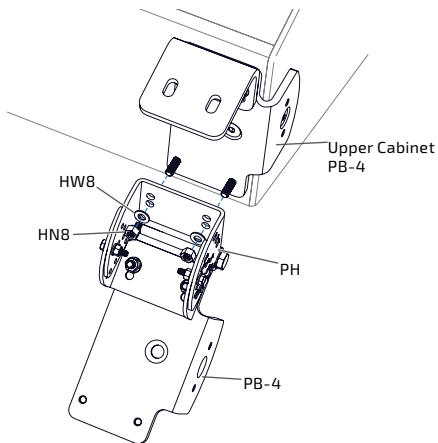

Figure 16-5. Attach hinge/ bracket assembly to the upper cabinet - use the holes closest to the hinge pivot

6

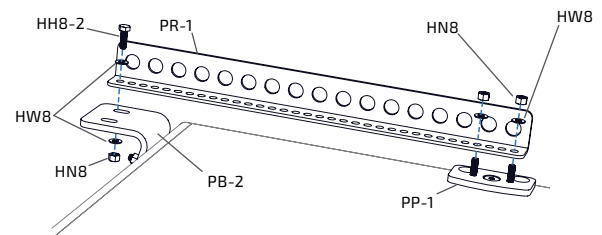

Figure 16-6. Attach both rails to upper cabinet and fully tighten connections

5 VERTICAL ARRAYS

VSB3-BFR22 (continued)

7

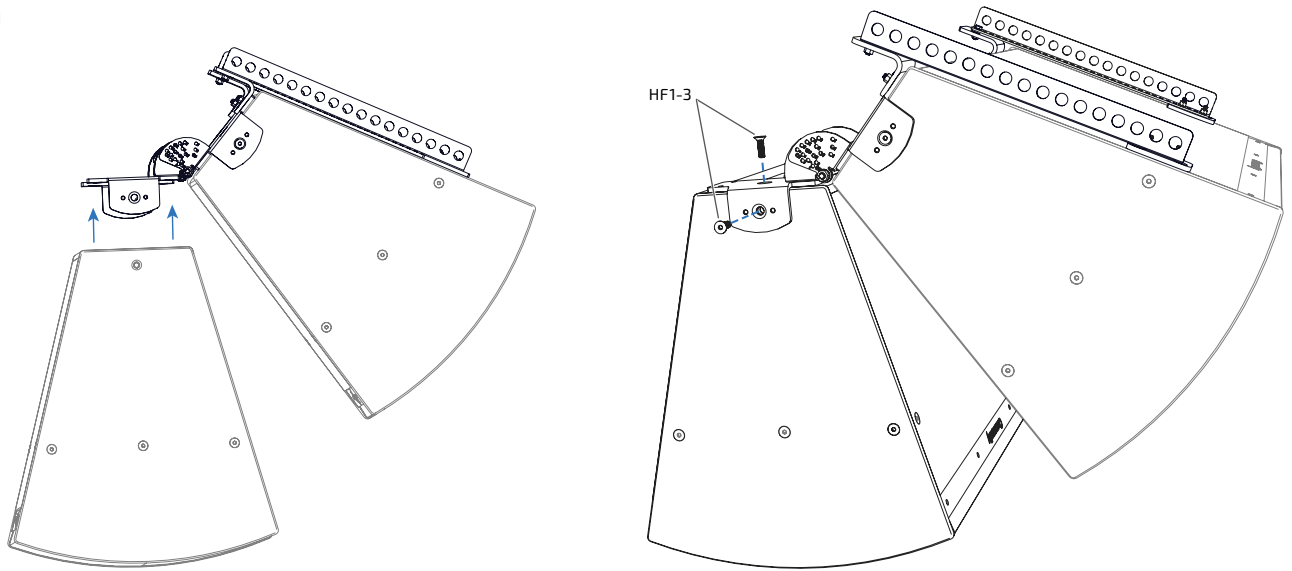

Figure 16-7. Remove the 6mm hardware and lift the lower cabinet up to the upper assembly
Attach lower cabinet to the hinge/bracket
Start all bolts before fully tightening them

8

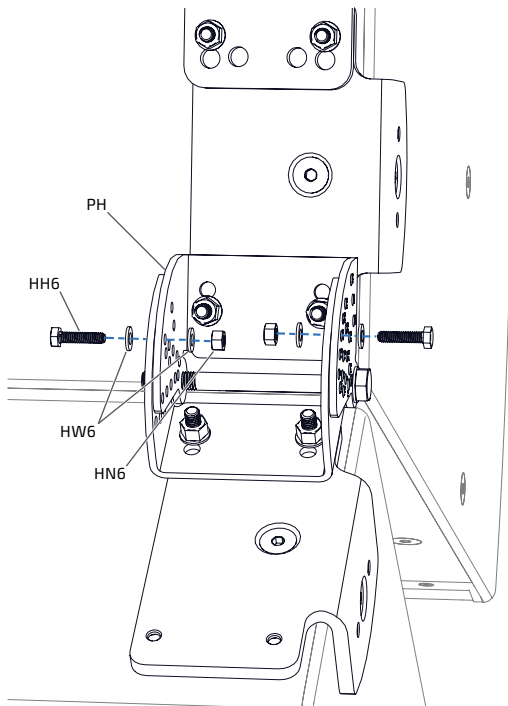

Figure 16-8. Adjust hinge to desired angle and reinsert the 6mm hardware
Snug tighten the 6mm connections until desired angle is confirmed, then fully tighten

9

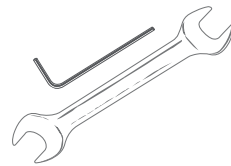
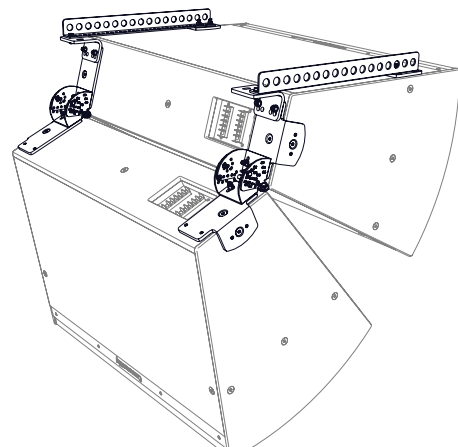

Figure 16-9. Fully tighten all connections



Assembled VSB3-BFR22

5 VERTICAL ARRAYS

VSBSBR54 - Dual Vertical Splay with Extension Kit for 2-way Models (Vertically array two 2-way loudspeakers with subwoofer behind)

APPLICATION: Suspend and vertically array two full-range 2-way loudspeakers (landscape orientation) with a subwoofer behind; connected with BalancePoint™ Fly Rails.

PREASSEMBLY:

Confirm that the 8mm hardware on the cabinet brackets is the correct position (See bolt pattern diagram below).

ASSEMBLY:

The array should be assembled from the top down by attaching the brackets and rails to what will be the top cabinet and then suspending it and adding the lower cabinet. After the lower full-range loudspeaker is connected the subwoofer can be lifted into position and attached to the rails.

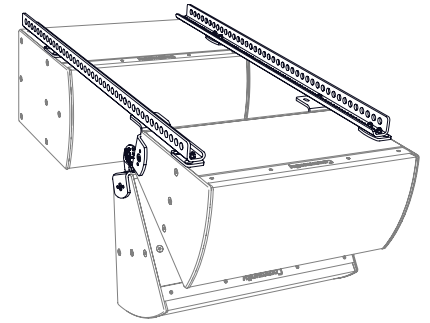

Parts:

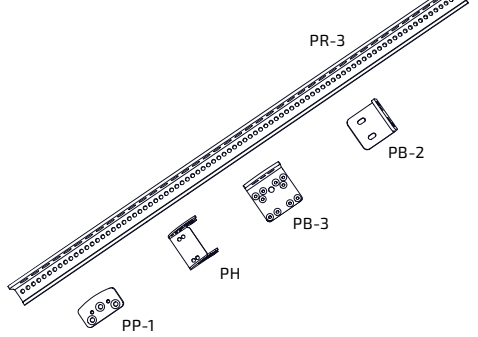

- PR-3: 54" BalancePoint™ Fly Rails (2)
- PP-1: Universal Mounting Plates (4)
- PB-2: Dual L Brackets (2)
- PB-3: Cabinet Brackets (4)
- PH: Hinge Brackets (4=2 preassemblies)

Hardware:

Qty	Code	Description
4	HH6	6 x 25 mm Hex Hd Bolts
4	HN6	M6 Locknuts
8	HW6	6mm Flat Washers
2	HH8-3	8 x 30 mm Hex Hd Bolts
20	HF8-3	8 x 30 mm Flat Hd Bolts
24	HW8	8mm Flat Washers
22	HN8	M8 Locknuts
2	HH1-12	10 x 120 mm Hex Hd Bolts
12	HF1-3	10 x 35 mm Flat Hd Bolts
4	HW1	10 mm Flat Washers
2	HN1	M10 Locknuts

Some hardware listed above will be included in plate and hinge preassemblies.

Note: One additional full-range cabinet may be added to the array by using one HVS kit, or an additional sub can be added by using a TPK kit.

Kit Weight: 37.0 lb (16.8 kg)

1 IP6/8-1122

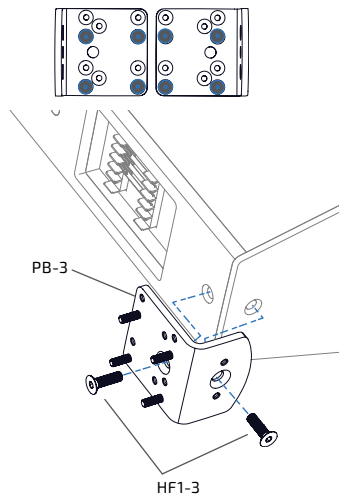

1 IP6/8-1152

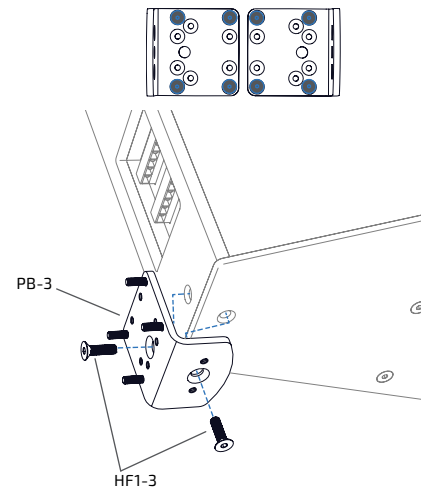
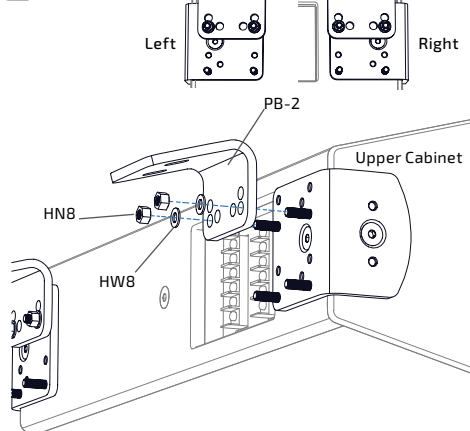

Figure 17-1. After removing the applicable cabinet bolts, place upper cabinet brackets (with flat head bolts inserted) on the cabinets as shown - note position of top bolts

2 IP6/8-1122



2 IP6/8-1152

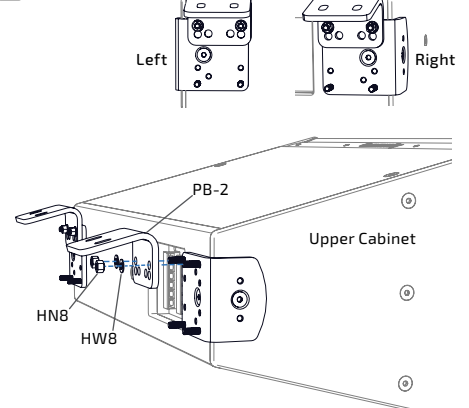

Figure 17-2. Attach the L brackets to the cabinet brackets - note which holes in the L bracket to use

5 VERTICAL ARRAYS

VSB-SBR54 (continued)

Best Practices:

For best aesthetics, the BalancePoint™ Fly Rails should not extend beyond the front of the loudspeakers.

Attach safety cable(s) to the loudspeakers and/or assembly as advised by a registered structural engineer.



Important: Cabinet and rail connections should be fully tightened (as you proceed) before suspending each component.

3

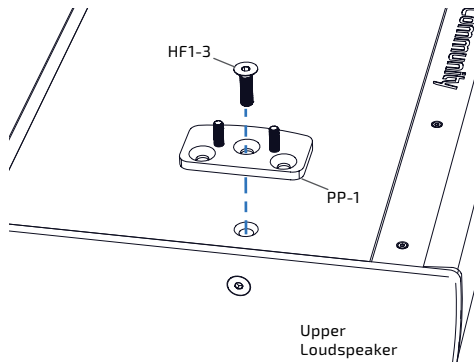

Figure 17-3. Attach PP-1 to enclosure - with outside edges parallel and fully tighten

4

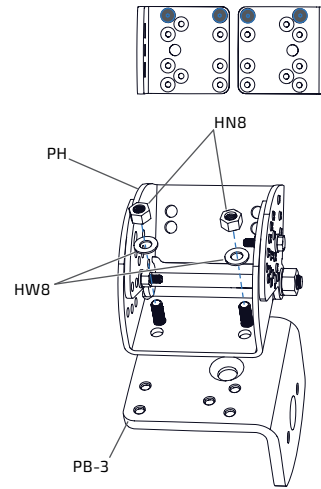

Figure 17-4. Attach hinges (2) to remaining cabinet brackets - use the holes closest to the hinge pivot

5

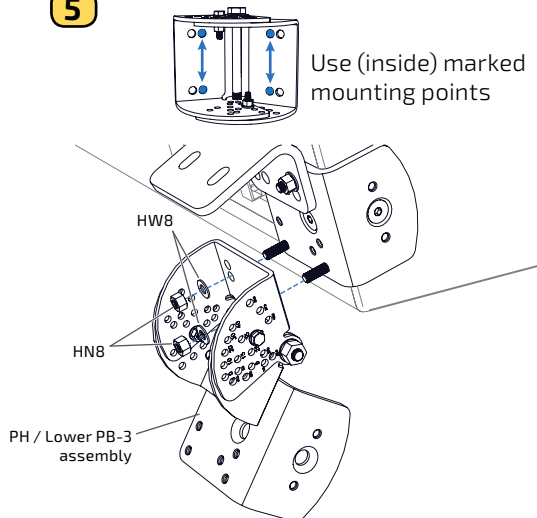

Figure 17-5. Attach hinge/ bracket assembly to the upper cabinet - use the holes closest to the hinge pivot

6

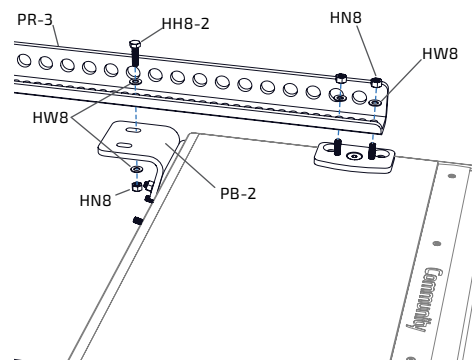

Figure 17-6. Attach rails to upper cabinet

5 VERTICAL ARRAYS

VSB-SBR54 (continued)

7

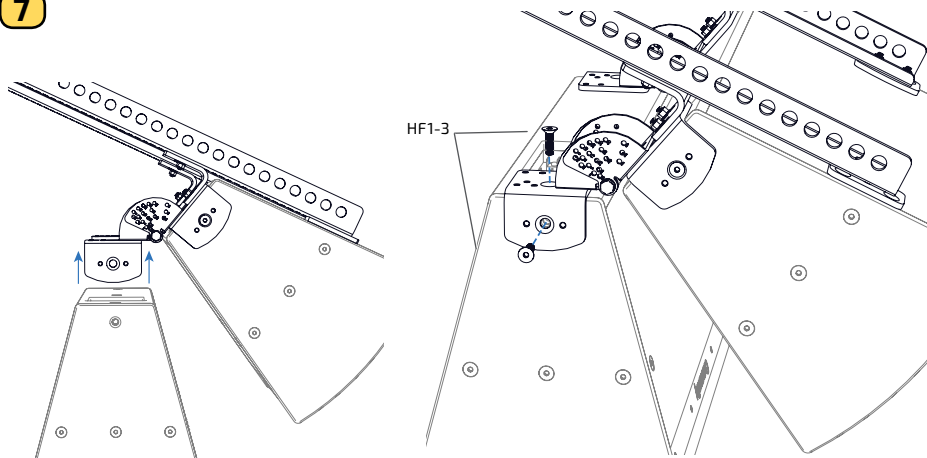

Figure 17-7. Lift the lower full-range cabinet into place and attach the cabinet brackets
Fully tighten those connections

8

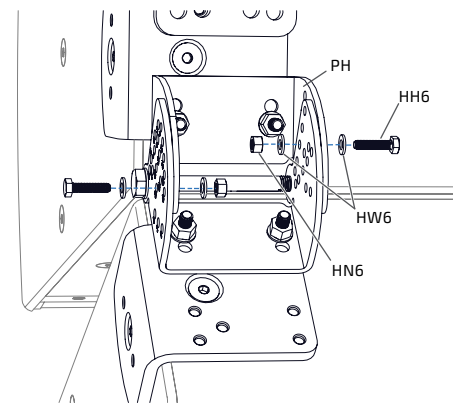

Figure 17-8. Adjust hinge to desired angle and reinsert the 6mm hardware
Snug tighten the 6mm connections until desired angle is confirmed, then fully tighten

9

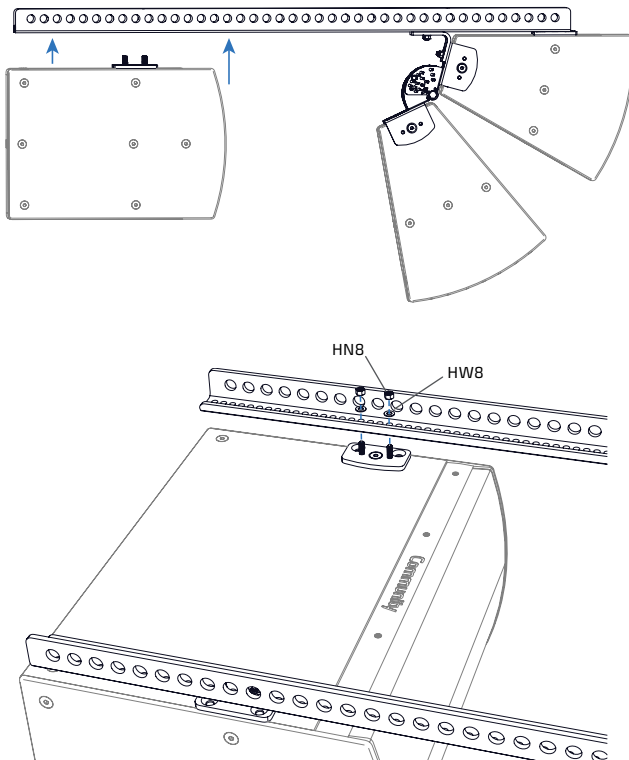

Figure 17-9. Lift the subwoofer into place under the rails and attach to the rails
Fully tighten the connections

10

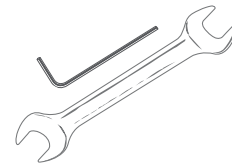

Figure 17-10. Fully tighten all connections

An additional subwoofer can be added under the subwoofer by using a tight pack kit (TPK). Attach the mounting plates to the lower subwoofer and lift into position then connect the two. They must be placed horizontally (landscape position). Do not exceed the Safe Working Load of 500 lbs with the full assembly.

5 VERTICAL ARRAYS

VS3-SBR54 - Dual Vertical Splay with Extension Kit for 3-way Models (Vertically array two 3-way loudspeakers with subwoofer(s) behind)

APPLICATION: Suspend and vertically array two full-range 3-way loudspeakers (landscape orientation of the loudspeakers) with BalancePoint™ Fly Rails with subwoofer(s) behind.

PREASSEMBLY:

Confirm that the 8mm hardware on the cabinet brackets is the correct position (See bolt pattern diagram below).

ASSEMBLY:

The array should be assembled from the top down by attaching the brackets and rails to what will be the top cabinet and then suspending it and adding the lower cabinet.

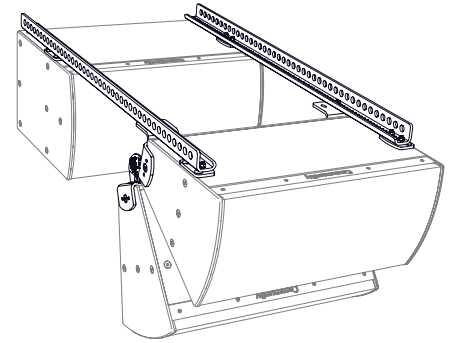

Parts:

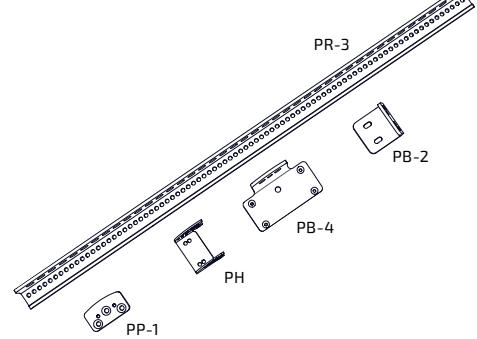

- PR-3: 54" BalancePoint™ Fly Rails (2)
- PP-1: Universal Mounting Plates (4)
- PH: Hinge Brackets (4=2 preassemblies)
- PB-4: Cabinet Brackets (4)
- PB-2: Dual L Brackets (2)

Hardware:

Qty	Code	Description
4	HH6	6 x 25 mm Hex Hd Bolts
4	HN6	M6 Locknuts
8	HW6	6mm Flat Washers
2	HH8-3	8 x 30 mm Hex Hd Bolts
20	HF8-3	8 x 30 mm Flat Hd Bolts
24	HW8	8mm Flat Washers
22	HN8	M8 Locknuts
2	HH1-12	10 x 120 mm Hex Hd Bolts
12	HF1-3	10 x 35 mm Flat Hd Bolts
4	HW1	10 mm Flat Washers
2	HN1	M10 Locknuts

Some hardware listed above will be included in plate and hinge preassemblies.

Note: One additional full-range cabinet may be added to the array by using one HV53 kit, or an additional sub can be added by using a TPK kit.

Kit Weight: 43.0 lb (19.5 kg)

1

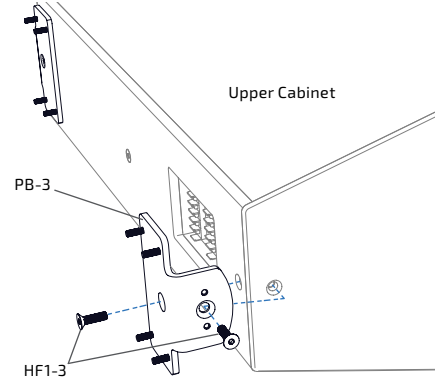
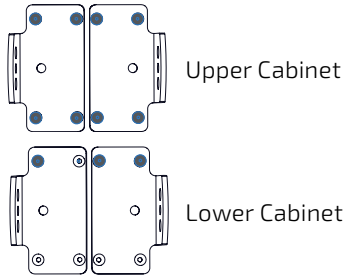

Figure 18-1. After removing the applicable cabinet bolts, place upper cabinet brackets (with flat head bolts inserted) on the cabinets as shown

2

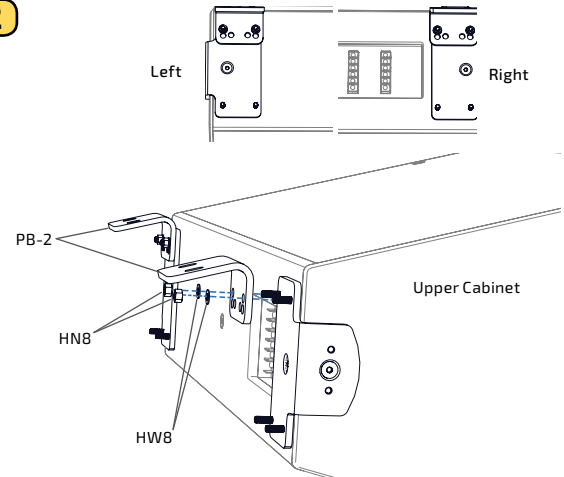

Figure 18-2. Attach the L brackets to the cabinet brackets - note which holes to use in the L bracket

5 VERTICAL ARRAYS

VSB3-SBR54 (continued)

Best Practices:

For best aesthetics, the BalancePoint™ Fly Rails should not extend beyond the front of the loudspeakers.

Attach safety cable(s) to the loudspeakers and/or assembly as advised by a registered structural engineer.



Important: Cabinet and rail connections should be fully tightened (as you proceed) before suspending each component.

3

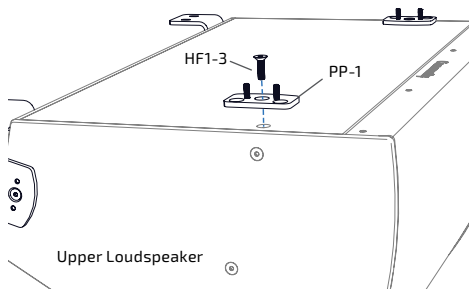

Figure 18-3. Attach PP-1 to enclosure - with outside edges parallel and fully tighten

4

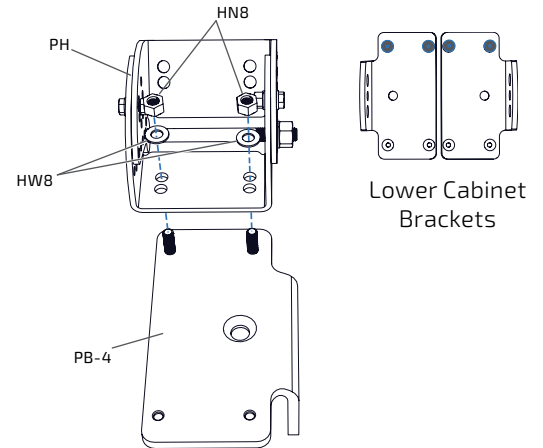

Figure 18-4. Attach hinges (2) to remaining cabinet brackets
- use the holes closest to the hinge pivot

5

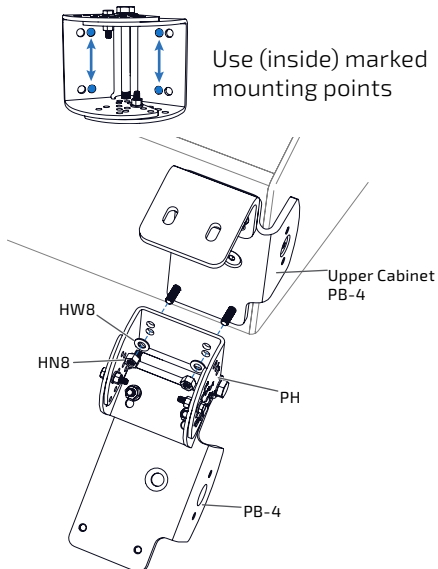

Figure 18-5. Attach hinge/ bracket assembly to the upper cabinet
- use the holes closest to the hinge pivot

6

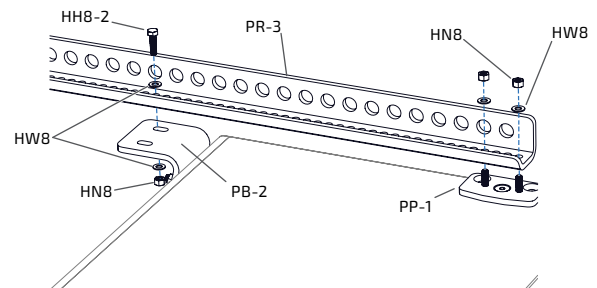

Figure 18-6. Attach both rails to upper cabinet and fully tighten connections

5 VERTICAL ARRAYS

VSB3-SBR54 (continued)

7

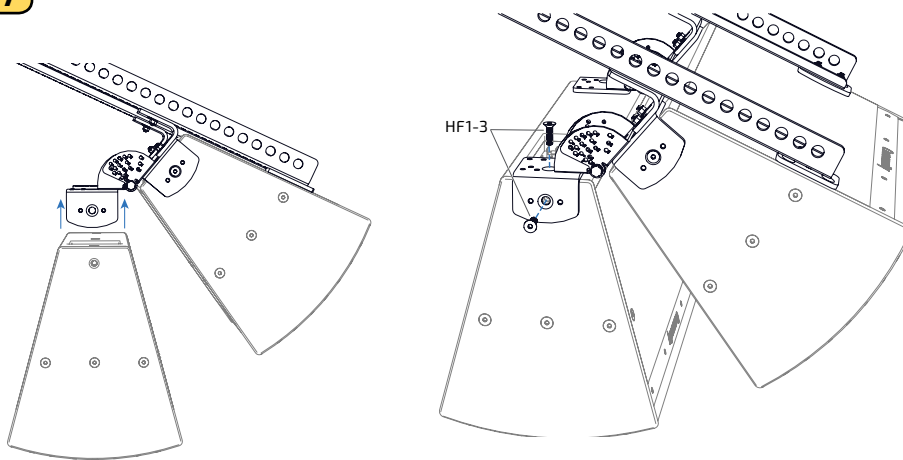

Figure 18-7. Remove the 6mm hardware and lift the lower cabinet up to the upper assembly
Attach lower cabinet to the hinge/bracket
Start all bolts before fully tightening them

8

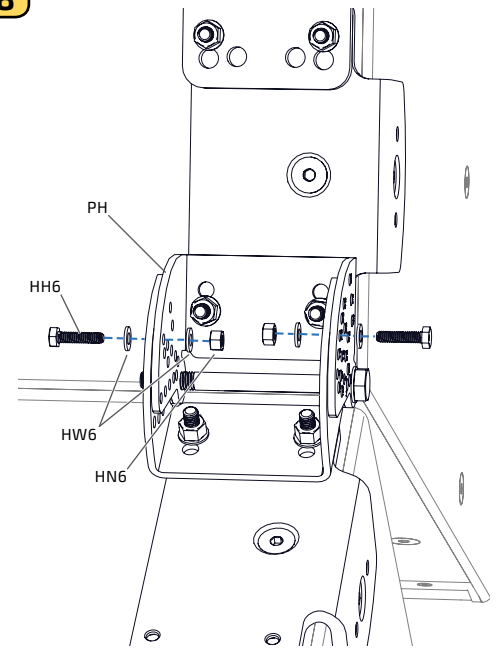

Figure 18-8. Adjust hinge to desired angle and reinsert the 6mm hardware
Snug tighten the 6mm connections until desired angle is confirmed, then fully tighten

9

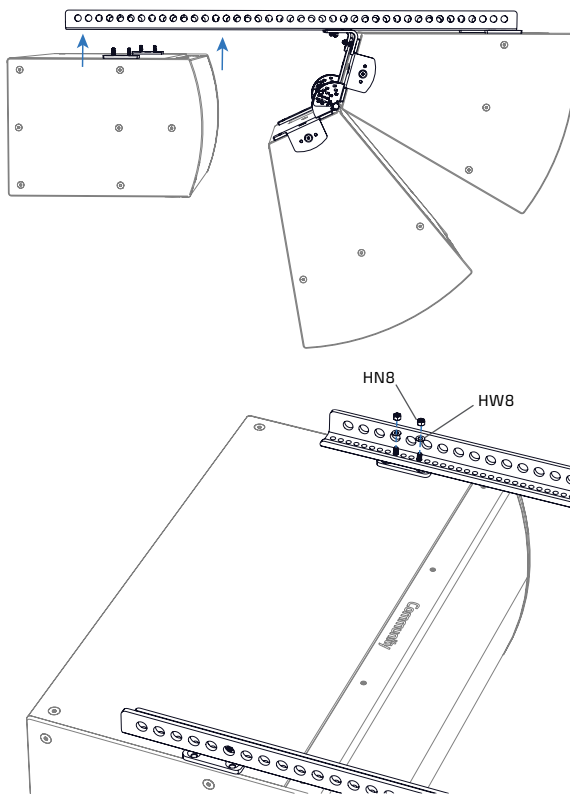

Figure 18-9. Lift the subwoofer into place under the rails and attach to the rails
Fully tighten the connections

10

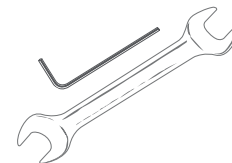

Figure 18-10. Fully tighten all connections

An additional subwoofer can be added under the subwoofer by using a tight pack kit (TPK). Attach the mounting plates to the lower subwoofer and lift into position then connect the two. They must be placed horizontally (landscape position). Do not exceed the Safe Working Load of 500 lbs with the full assembly.

5 VERTICAL ARRAYS

VAB-BFR38 - Vertical Array Brackets with BalancePoint™ Fly Rails

APPLICATION: Suspend and vertically array a subwoofer above a matching size 2-way/3-way loudspeaker (landscape orientation of the loudspeakers) with BalancePoint™ Fly Rails.

ASSEMBLY:

The array can be assembled from the top down by attaching the brackets and rails to subwoofer, suspending it and then adding the lower cabinet, or (for smaller models) the full unit can be assembled on the floor (on a protected surface) and then lifted/ flown.

Easiest order of assembly. Attach the array plate to the full-range cabinet, leaving connections loose, and then lift the lower cabinet to the subwoofer and attach. Fly Rail fasteners must all be fully tightened before suspending the subwoofer. Hex bolts connecting the array bracket to the full-range cabinet should be left slightly loose until aiming angle is set, then fully tightened.

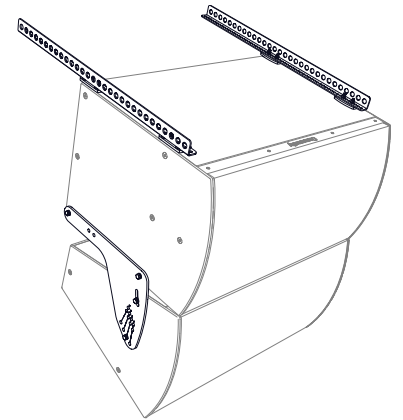

Parts:

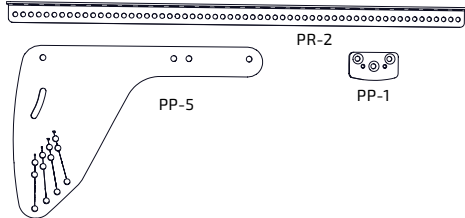

- PR-2: 38" BalancePoint™ Fly Rails (2)
- PP-1: Universal Mounting Plates (4)
- PP-5: Array Plates (2)

Hardware:

Qty	Code	Description
8	HF8-3	8 x 30 mm Flat Hd Bolts
8	HN8	M8 Locknuts
8	HW8	8mm Flat Washers
8	HH1-4	10 x 40 mm Hex Hd Bolts
4	HF1-3	10 x 35 mm Flat Hd Bolts
8	HW1	10 mm Flat Washers
8	HL1	10 mm Lock Washers

The 8mm flat head hardware listed above may be included in plate preassemblies.

Kit Weight: 36.0 lb (16.3 kg)

Models that can be paired:

- IP6/IP6 1122 with IS6/IS8 212
- IP8 1153 with IS6/IS8 215 or IS6/IS8 218

NOTE: The IP6/8-1152 currently is without a matched-width subwoofer.

Another full-range cabinet can be added by using the applicable HVS or HVS3 extension kit, or another subwoofer can be added by utilizing a Tight Pack kit to connect the subwoofers.

1

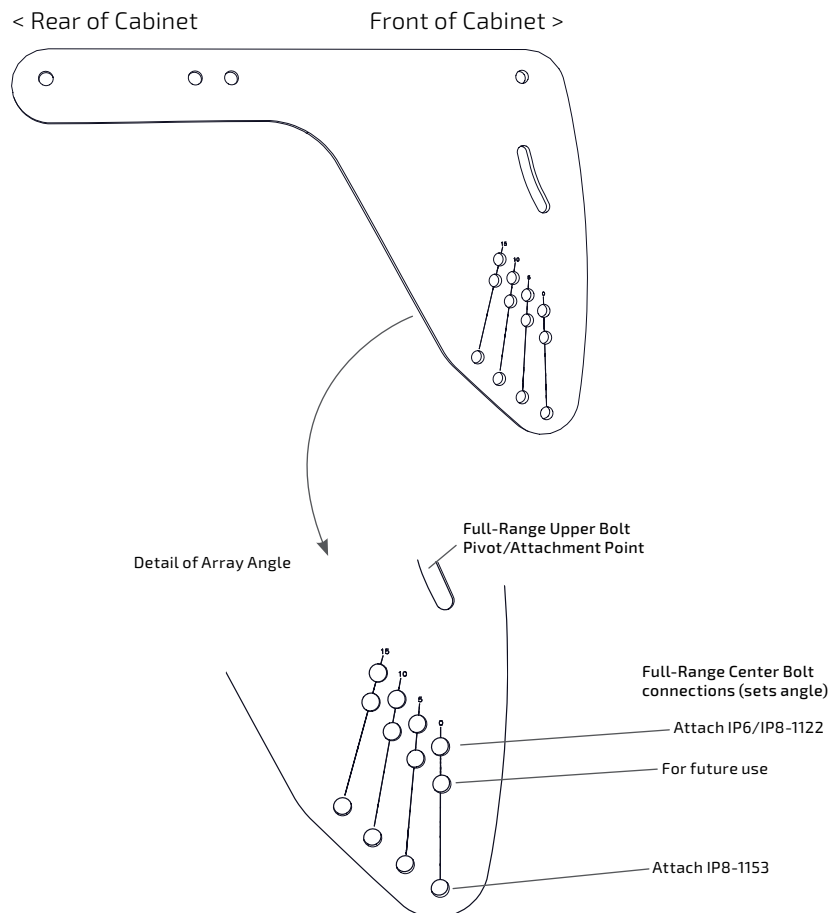

Figure 19 -1. Vertical array plate - orientation and attachment details

5 VERTICAL ARRAYS

VAB-BFR38 (continued)

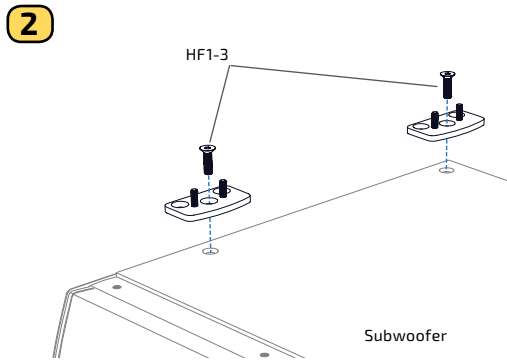

Figure 19-2. Attach 2 plates to each side, and fully tighten (oriented with flat sides toward the outside edges of the subwoofer)

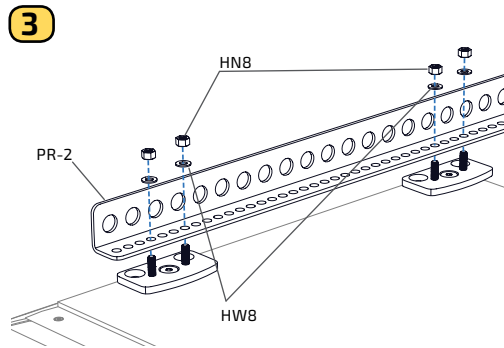

Figure 19-3. Attach a rail to each side
Do not extend rails over or beyond the Community sidebar (front of subwoofer)

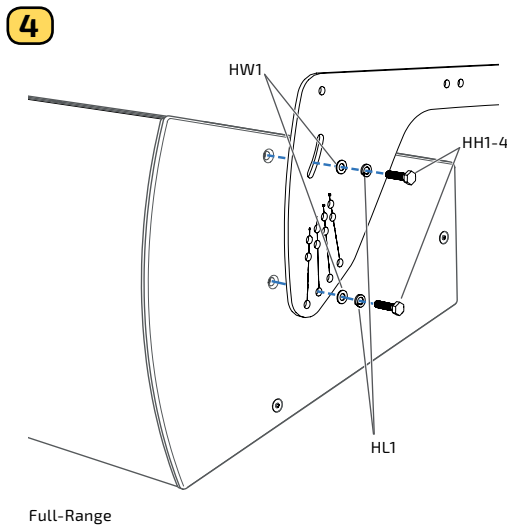

Figure 19-4. Attach bracket to full-range cabinet and leave bolts loose

Note: If lifting the Full-range cabinet up to the Sub, temporarily set the angle to 0° to make sub connection easier, then move bolt to desired angle setting.

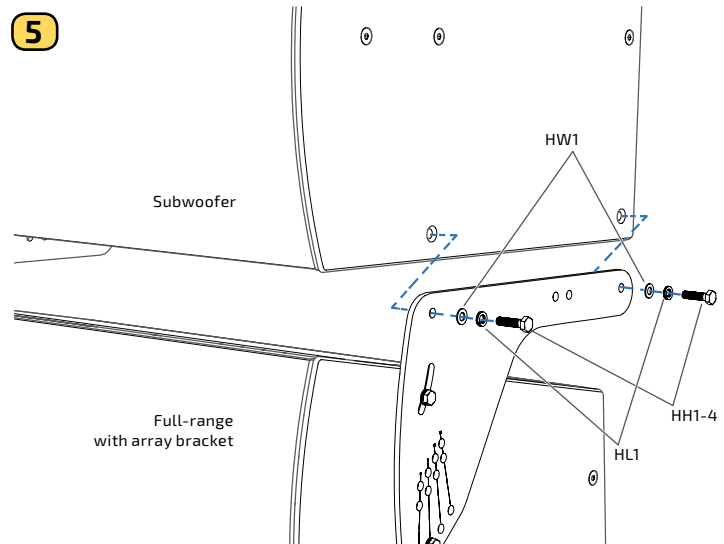

Figure 19-5. Lift the full-range loudspeaker up to the subwoofer and attach the subwoofer to the array bracket

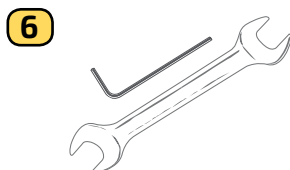

Figure 19-6.
Fully tighten all connections

SUSPENSION TIPS

If no motorized lift point is available: 1) Move first subwoofer with the rails into its permanent position and add temporary cables to move the subwoofer into a level (parallel to lift surface) position; 2) Lift any additional subwoofers one at a time and fasten to the sub above; 3) Add the full-range cabinet with the array plate attached/loose (and rotational brackets), and connect to the sub above; 4) Set the angle on the full-range and tighten bolts; 5) Lift and add additional full-range cabinets. Any rotational (hinge) brackets should have corner brackets attached and ride with the upper cabinets for easier connectivity.

If motorized lift points are available: Assemble from the top down and tighten bolt connections as you move down the stack.

5 VERTICAL ARRAYS

DVS-BFR22 - Dual Vertical Splay Kit for Two Vertical Enclosures (no U-Brackets)

APPLICATION: Suspend and splay two vertically oriented enclosures with BalancePoint™ Fly Rails. Can be used with or without optional U-Brackets to provide extra aiming capability.

ASSEMBLY:

The array can be assembled from the top down by attaching the brackets and rails to what will be the top cabinet and then suspending it and adding the lower cabinet, or the full unit can be assembled horizontally on the floor (on a protected surface), and then lifted/flown.

There are three (3) sets of assembly instructions for this kit: no U-Brackets, one (1) U-Bracket, or two (2) U-Brackets. Use the appropriate version for your application.

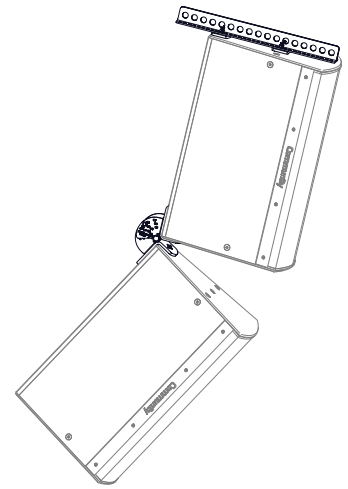

Parts:

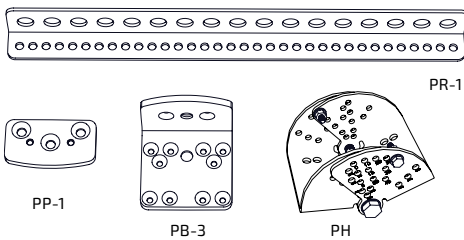

- PR-1: 22" BalancePoint™ Fly Rails (2)
- PP-1: Universal Mounting Plates (2)
- PB-3: Cabinet Brackets (2)
- PH: Hinge Preassembly (1)

Hardware:

Qty	Code	Description
2	HH6	6 x 25 mm Hex Hd Bolts
2	HN6	M6 Locknuts
4	HW6	6mm Flat Washers
4	HH8-3	8 x 30 mm Hex Hd Bolts
8	HF8-3	8 x 30 mm Flat Hd Bolts
8	HN8	M8 Locknuts
12	HW8	8mm Flat Washers
4	HF1-3	10 x 35 mm Flat Hd Bolts
2	HF1-4	10 x 40 mm Flat Hd Bolts
1	HH1-12	10 x 120 mm Hex Hd Bolt
3	HW1	10 mm Flat Washers
2	HN1	M10 Locknuts

Some of the hardware listed above will be included in plate and hinge preassemblies.

Kit Weight: 17.0 lb (7.7 kg)

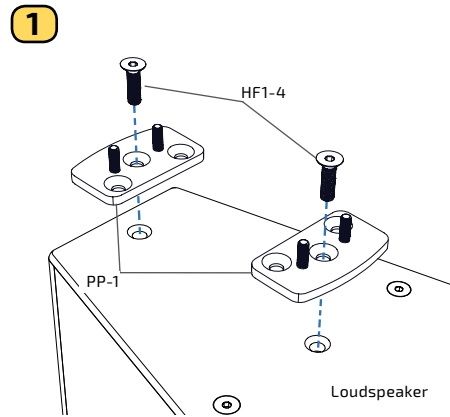

Figure 20-1. Attach plates to enclosure

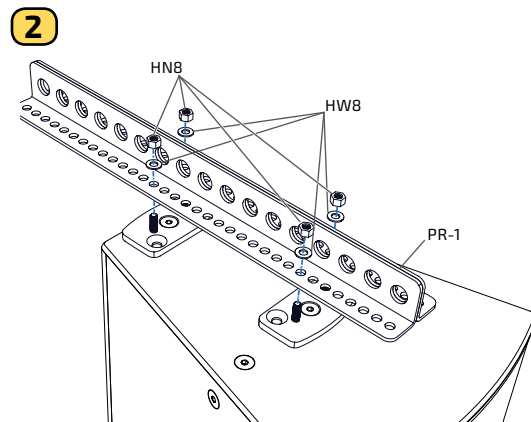

Figure 20-2. Attach rails to plates / brackets

5 VERTICAL ARRAYS

DVS-BFR22 (no U-Brackets continued)

Best Practices:

Set the loudspeakers on a protected surface in the proper arrangement before assembling the array. Remove only the flat head bolts in the cabinet that are necessary to mount the rigging brackets. All other bolts should be left in place.

All bolts should be fully tightened before the assembly is lifted into place.

Attach safety cable(s) to the loudspeakers and/or assembly as advised by a registered structural engineer.

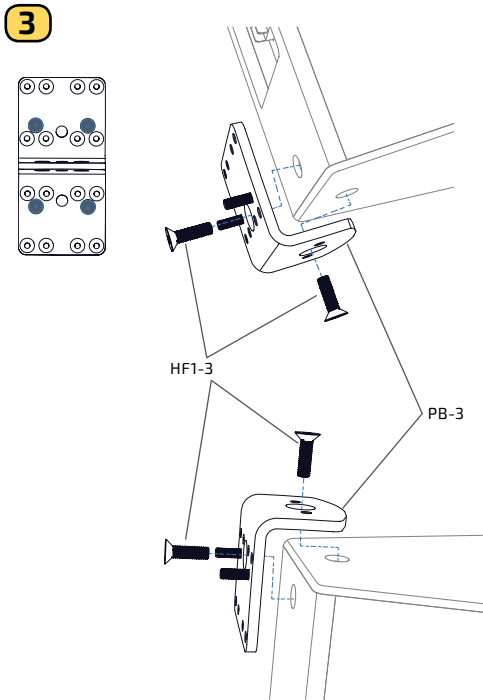

Figure 20-3. Confirm that the 8mm flat head bolts are threaded into each cabinet bracket as shown, and attach them to the cabinets

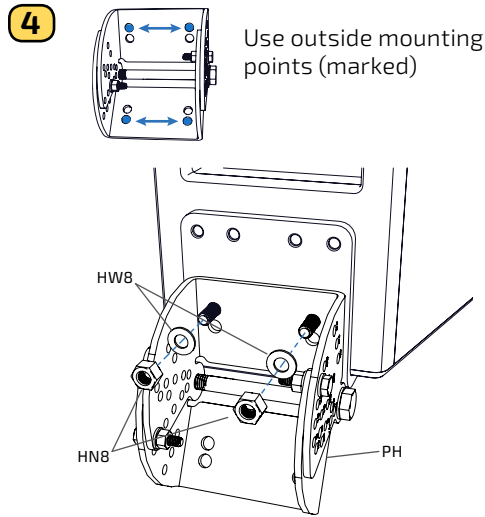

Figure 20-4. Attach hinge assembly to upper cabinet

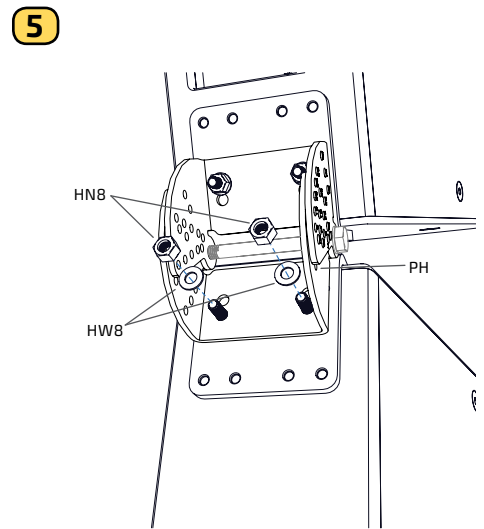

Figure 20-5. Remove 6mm hardware (securing the angle) and attach lower cabinet

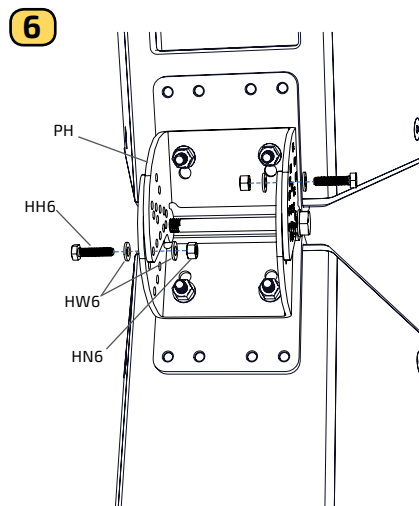

Figure 20-6. Set the splay angle by reattaching the 6mm hardware

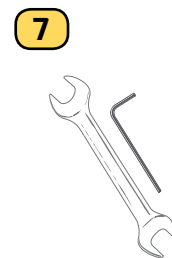

Figure 20-7. Fully tighten all connections



CAUTION: Installation of I SERIES loudspeakers should only be performed by trained and qualified personnel. It is strongly recommended that a licensed and certified professional structural engineer approve the mounting. Severe injury and/or loss of life may occur if this product is improperly installed.

5 VERTICAL ARRAYS

DVS-BFR22 (alternate configurations) with 1 U-Bracket on the lower loudspeaker

ASSEMBLY:

The array can be assembled from the top down by attaching the brackets and rails to what will be the top cabinet and then suspending it and adding the lower cabinet, or the full unit can be assembled horizontally on the floor (on a protected surface), and then lifted/flown.

USING 1 U-BRACKET

The loudspeaker with the U-Bracket will be the lower cabinet in this configuration. Install the U-Bracket on that loudspeaker (see U-Bracket instructions).

Note: You will have some leftover hardware (8mm bolts, bolts, washers), and 1 cabinet bracket will not be used.

Fully tighten all hardware before suspending

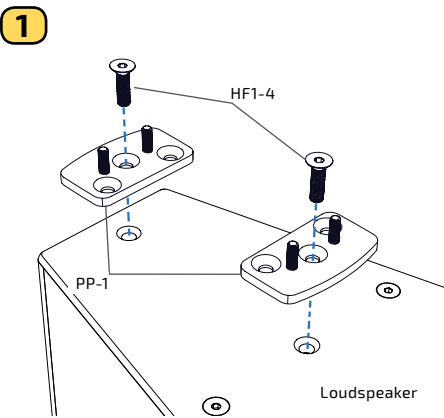
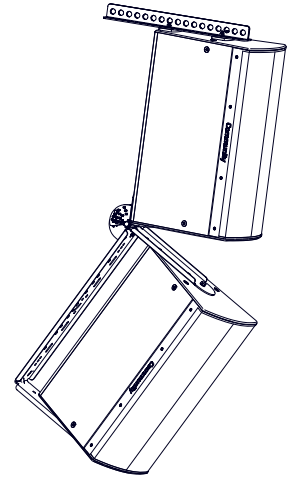

Figure 21-1. Attach plates to enclosure

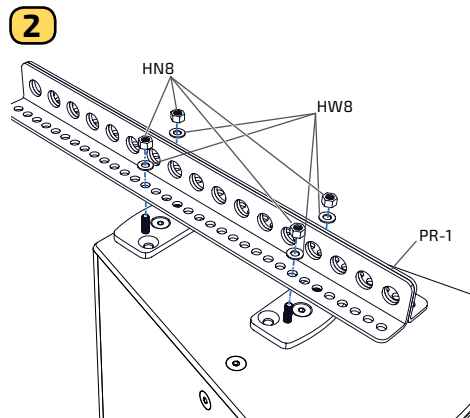

Figure 21-2. Attach rails to plates

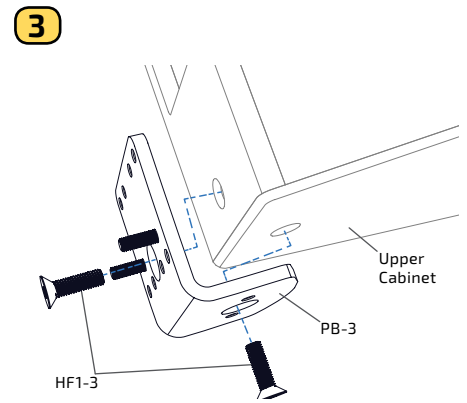

Figure 21-3. Attach cabinet bracket to the upper cabinet

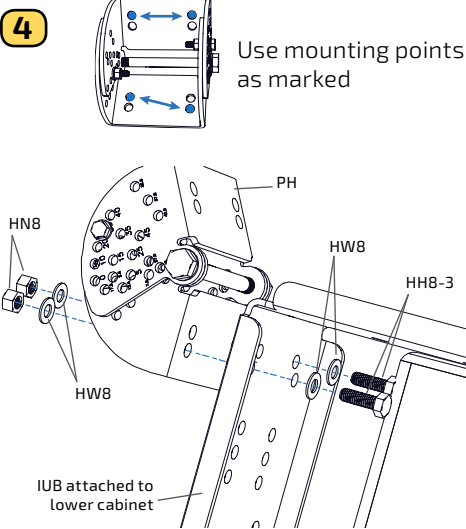

Figure 21-4. Attach hinge to the U-Bracket

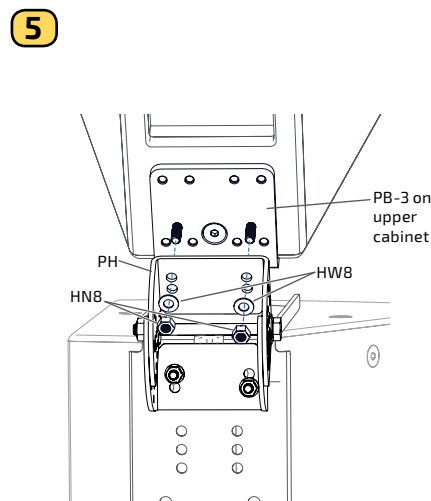

Figure 21-5. Remove 6mm hardware (securing the angle) and attach hinge to the cabinet bracket on the upper cabinet

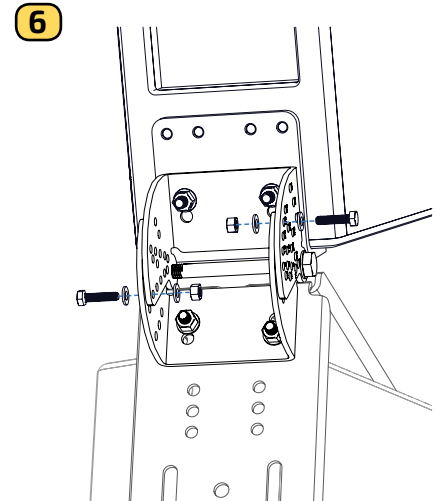

Figure 21-6. Set the splay angle by reattaching the 6mm hardware
Fully tighten connections

5 VERTICAL ARRAYS

DVS-BFR22 (alternate configurations) with 2 U-Brackets on the loudspeakers

ASSEMBLY:

The array can be assembled from the top down by attaching the brackets and rails to what will be the top cabinet and then suspending it and adding the lower cabinet, or the full unit can be assembled horizontally on the floor (on a protected surface) and then lifted/flown. Panning angles can be adjusted once fully assembled and suspended.

Install the U-Brackets on the loudspeakers, but leave the connections loose.

Remove the hardware (hex bolt, flat washer, lock washer) connecting the U-Bracket to the top of the upper loudspeaker, and attach the mounting plates (Figure 22-1). Keep the large washer between the loudspeaker and the U-Bracket.

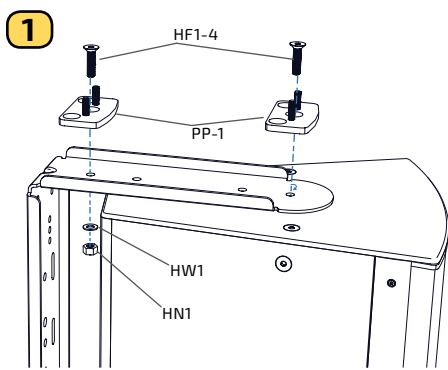
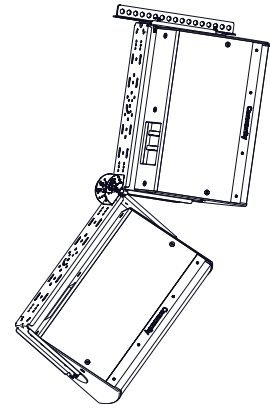

Figure 22-1. Attach mounting plates to U-Bracket and cabinet

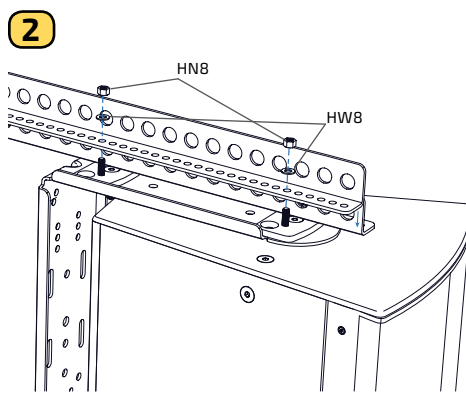
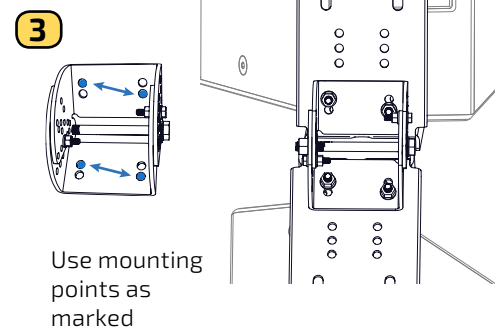

Figure 22-2. Attach fly rails to U-Bracket



Use mounting points as marked

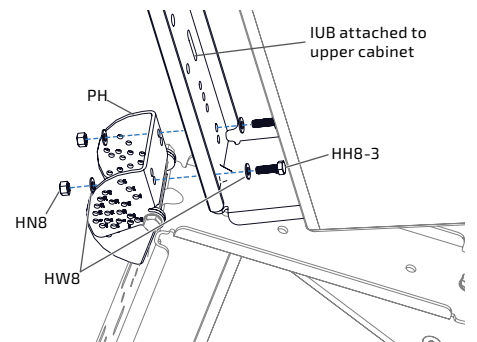

Figure 22-3. Attach hinge to U-Brackets

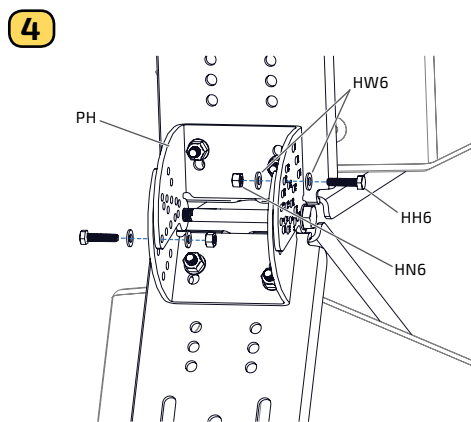

Figure 22-4. Set the splay angle by reattaching the 6mm hardware

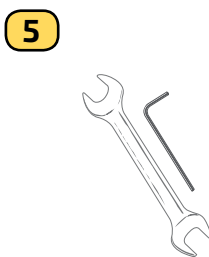

Figure 22-5. Fully tighten all connections

6 ARRAY ACCESSORIES

DFS - Downfill Splay Bracket Kit

APPLICATION: Suspend and splay a vertically oriented enclosure under another vertically oriented enclosure or loudspeaker array.

ASSEMBLY:

The array should be assembled from the top down by attaching the cabinet bracket to what will be the top cabinet and then suspending it and adding the lower cabinet.

Best Practices:

Set the loudspeakers on a protected surface in the proper arrangement before assembling the array. Remove only the flat head bolts in the cabinet that are necessary to mount the rigging brackets. All other bolts should be left in place.

All bolts should be fully tightened before the assembly is lifted into place.

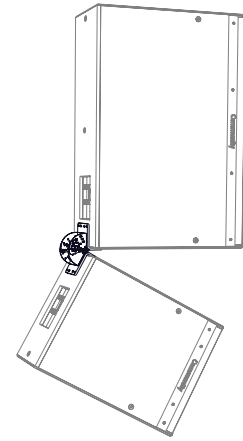

Parts:

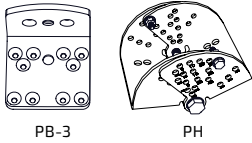

PB-3: Cabinet Brackets (2)
PH: Hinge Preassembly (1)

Hardware:

Qty	Code	Description
2	HH6	6 x 25 mm Hex Hd Bolts
2	HN6	M6 Locknuts
4	HW6	6mm Flat Washers
4	HH8-2	8 x 25 mm Hex Hd Bolts
4	HF8-3	8 x 30 mm Flat Hd Bolts
4	HN8	M8 Locknuts
8	HW8	8mm Flat Washers
4	HF1-3	10 x 35 mm Flat Hd Bolts
1	HH1-12	10 x 120 mm Hex Hd Bolt
2	HW1	10 mm Flat Washers
1	HN1	M10 Locknut

Some of the hardware listed above will be included in plate and hinge preassemblies.

Kit Weight: 10.0 lb (4.5 kg)

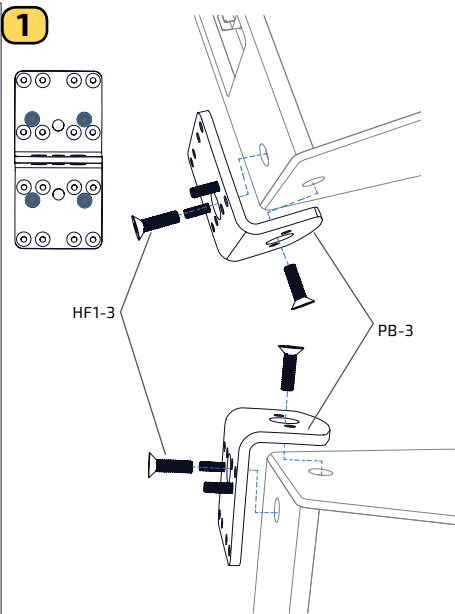

Figure 23-1. Confirm that the 8mm flat head bolts are threaded into each cabinet bracket as shown, and attach them to the cabinets

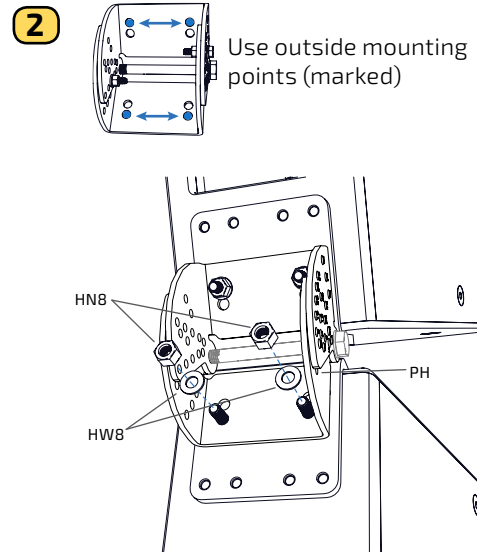

Figure 23-2. Remove 6mm hardware (securing the angle) and attach the hinge to the upper cabinet and then the lower one - leave connections loose until both cabinets have been connected

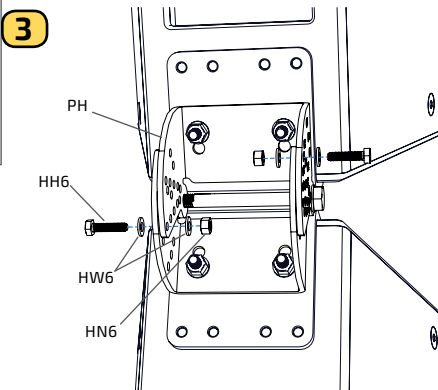

Figure 23-3. Set the splay angle by reattaching the 6mm hardware

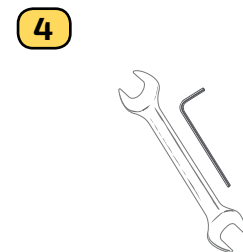

Figure 23-4. Fully tighten all connections

6 ARRAY ACCESSORIES

HVS - Horizontal/Vertical Splay Bracket Extension Kit (2-way)

APPLICATION: Add an additional enclosure to a full-range loudspeaker in a 2-way Horizontally or Vertically Splayed configuration.

ASSEMBLY:

This kit includes the (4) 8mm bolts that may need to be threaded into the adjacent full range cabinet's corner brackets before they are attached to that cabinet. There are several configurations possible and the specific bolt locations in the cabinet brackets are shown. Follow the instructions and general order of assembly accompanying the kit that you are adding the third cabinet to.

When attaching the hinges to the cabinet brackets it will be easier to remove the 6mm hardware and allow the hinge to move. After the hinge is attached, set the hinge angle and secure with the 6mm hardware.

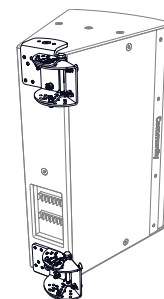
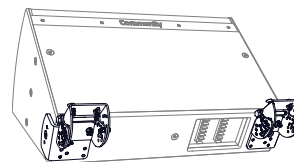

Parts:

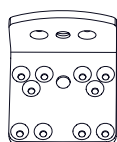

PB-3

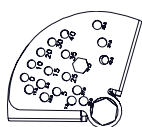

PH (preassembled)

PB-3 : 2-way Cabinet Brackets (4)

PH: Preassembled Hinges (2)

Hardware:

Qty	Code	Description
4	HH6	6 x 25 mm Hex Hd Bolts
4	HN6	M6 Locknuts
8	HW6	6mm Flat Washers
8	HF8-3	8 x 30 mm Flat Hd Bolts
8	HN8	M8 Locknuts
8	HW8	8mm Flat Washers
8	HF1-3	10 x 35 mm Flat Hd Bolts
2	HH1-12	10 x 120 mm Hex Hd Bolt
4	HW1	10 mm Flat Washers
2	HN1	M10 Locknuts

Some of the hardware listed above may be included in plate and hinge preassemblies.

Kit Weight: 15.0 lb (6.8 kg)

If attaching to a HSB or VSB kit, there will be (2) cabinet brackets (PB-3) and some hardware not used. If necessary, remove the flat head bolts pre-installed in the extra PB-3s and use on the middle cabinet.

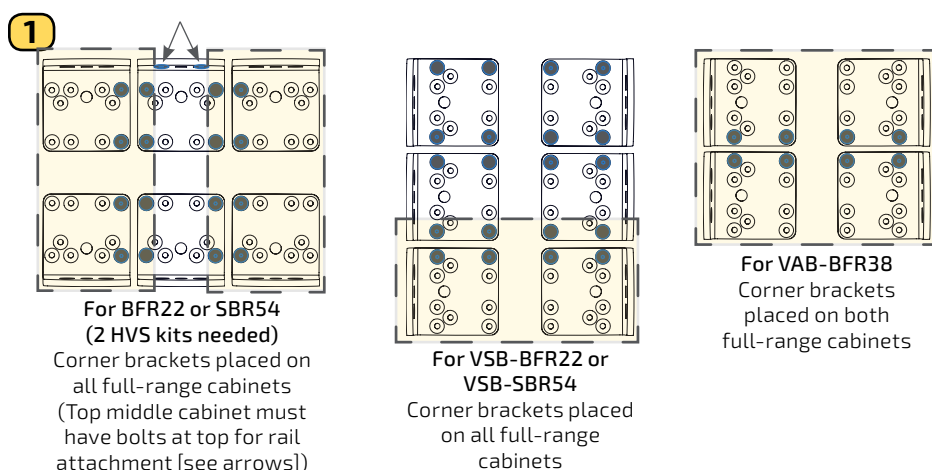

Figure 24-1. 8mm flat head bolt positions in cabinet brackets by kit application. (Lightly shaded outlined items are included in the HVS kit) Brackets are shown in their orientation on the full-range cabinets.

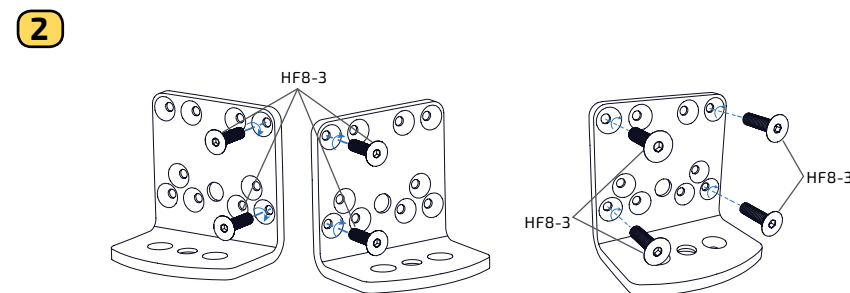

Figure 24-2. Confirm bolt placement and thread bolts into cabinet brackets in locations as needed for your specific kit.

6 ARRAY ACCESSORIES

HVS (continued)

Best practices:

Orient hinges so that the nut securing the long bolt (hinge pivot) is at the bottom (direction of gravity) when mounted to a vertically oriented loudspeaker.

Horizontal arrays can be fully assembled on the ground or lifting surface.

It is easier to assemble vertical arrays from the upper cabinet down, lifting each cabinet into position and then attaching the lower one to it. Smaller models can be assembled horizontally on the ground and then carefully lifted with proper support. Hinge angles should be set after each loudspeaker is secured to the upper cabinet.

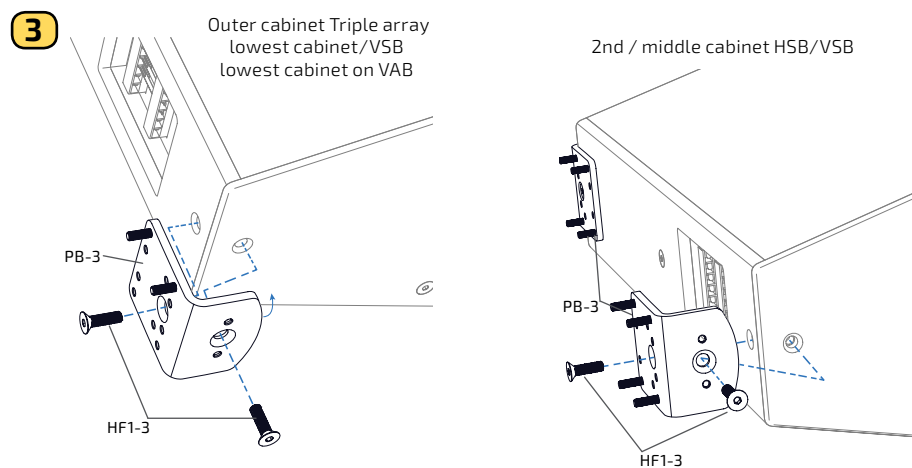

Figure 24-3. Attach the cabinet brackets with installed bolts on each cabinet

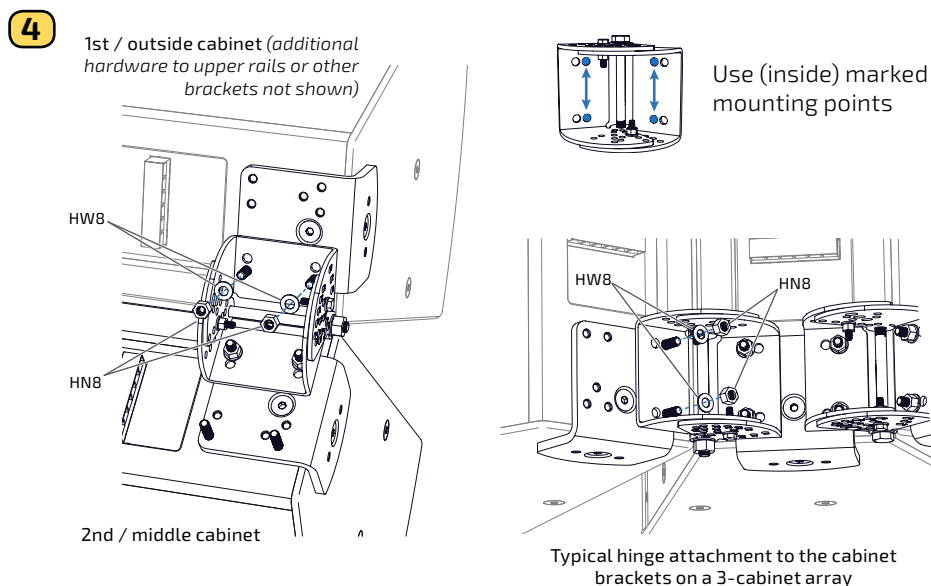

Figure 24-4. Remove the 6mm hardware from the hinges and connect the cabinets by attaching the hinge assemblies to the cabinet brackets (build from the top > down, or inside > outside) Reserve 6mm hardware to secure the splay angle after the cabinets have been connected.

Triple horizontal full-range 2-way array can be accomplished two ways: HSB-BFR22 / HSB-SBR54 + (1) HVS kit or BFR22V / SBR54 + (2) HVS kits.

Remove (2) 8mm flat head bolts from the PP-2 (or PP-1) and thread them into the top of what will be the middle cabinet top bracket. Attach all cabinet brackets and mounting plates to the cabinets. Attach the hinges. Attach the rails and fully tighten all rail and cabinet connections. Set the angles on the hinges - they must be symmetrical to balance evenly.

The PP-2 will not be used, and there will be hardware and a few parts left over.

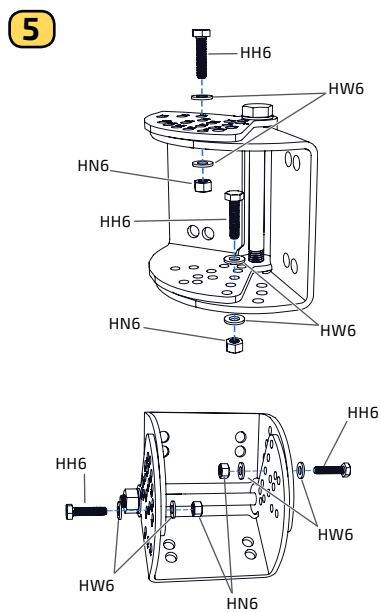

Figure 24-5. Set the desired angle

6 ARRAY ACCESSORIES

HVS3 - Horizontal/Vertical Splay Bracket Extension Kit (3-way)

APPLICATION: Add an additional enclosure to a full-range loudspeaker in a 3-way Horizontally or Vertically Splayed configuration.

ASSEMBLY:

This kit includes the (4) 8mm bolts that may need to be threaded into the adjacent full range cabinet's corner brackets before they are attached to that cabinet. There are several configurations possible and the specific bolt locations in the cabinet brackets are shown below. Follow the instructions and general order of assembly accompanying the kit that you are adding the third cabinet to.

When attaching the hinges to the cabinet brackets it will be easier to remove the 6mm hardware and allow the hinge to move. After the hinge is attached, set the hinge angle and secure with the 6mm hardware.

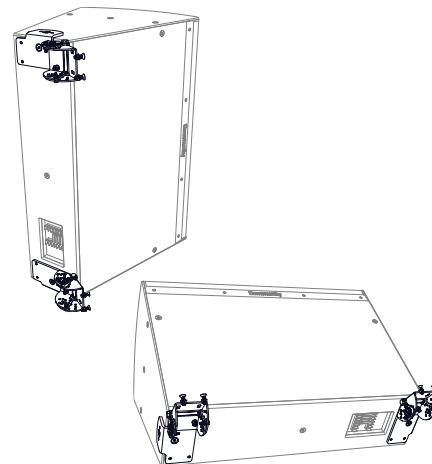

Parts:

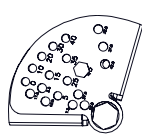

PH (preassembled)

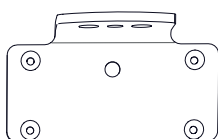

PB-4

PB-4 : 3-way Cabinet Brackets (4)

PH: Preassembled Hinges (2)

Hardware:

Qty	Code	Description
4	HH6	6 x 25 mm Hex Hd Bolts
4	HN6	M6 Locknuts
8	HW6	6mm Flat Washers
8	HF8-3	8 x 30 mm Flat Hd Bolts
8	HN8	M8 Locknuts
8	HW8	8mm Flat Washers
8	HF1-3	10 x 35 mm Flat Hd Bolts
2	HH1-12	10 x 120 mm Hex Hd Bolt
4	HW1	10 mm Flat Washers
2	HN1	M10 Locknut

Some of the hardware listed above may be included in plate and hinge preassemblies.

Kit Weight: 22.0 lb (10.0 kg)

If attaching to a HSB3 or VSB3 kit, there will be (2) cabinet brackets (PB-4) and some hardware not used. If necessary, remove the flat head bolts pre-installed in the extra PB-4s and use on the middle cabinet.

1

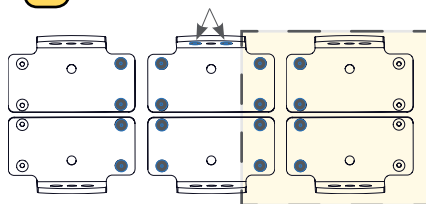

For HSB3-BFR22 or HSB3-SBR54
Corner brackets placed on all full-range cabinets
(Top middle cabinet must have bolts at top for rail attachment [arrows])

Bolt pattern for middle cabinet (top) bracket for horizontal array only

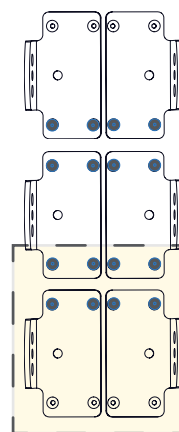
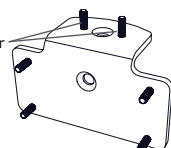

For VSB-BFR22 or VSB-SBR54
Corner brackets placed on all full-range cabinets

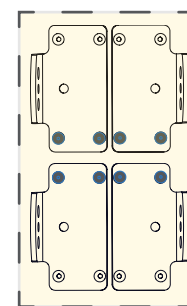

For VAB-BFR38 with 3-way full-range
Corner brackets placed on both full-range cabinets

Figure 24-1. 8mm flat head bolt positions in cabinet brackets by kit application. (Lightly shaded outlined items are included in the HVS3 kit) Brackets are shown in their orientation on the full-range cabinets.

2

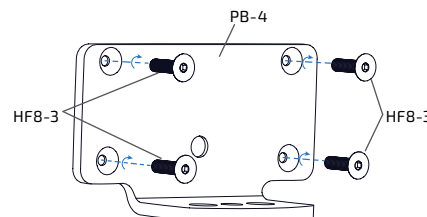
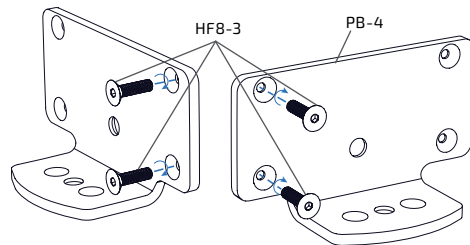

Figure 24-2. Confirm bolt placement and thread bolts into cabinet brackets in locations as needed for your specific kit.



WARNING: Do NOT exceed three (3) full-range cabinets in a single array. More than three will exceed the maximum safe working load.

6 ARRAY ACCESSORIES

HVS3 (continued)

Best practices:

Orient hinges so that the nut securing the long bolt (hinge pivot) is at the bottom (direction of gravity) when mounted to a vertically oriented loudspeaker.

Horizontal arrays can be fully assembled on the ground or lifting surface.

It is easier to assemble vertical arrays from the upper cabinet down, lifting each cabinet into position and then attaching the lower one to it. Hinge angles should be set after each loudspeaker is secured to the upper cabinet.

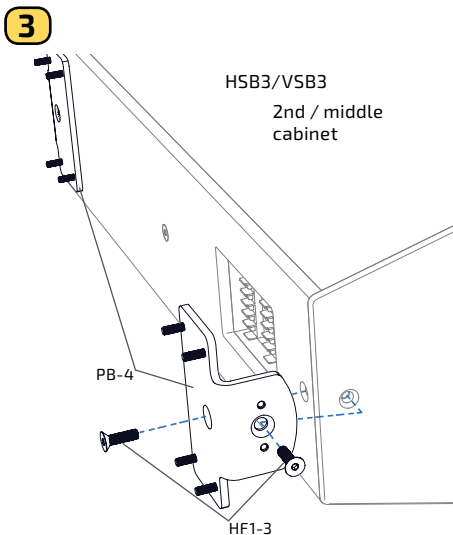

Figure 24-3. Attach the cabinet brackets with 4 installed bolts to the middle cabinet

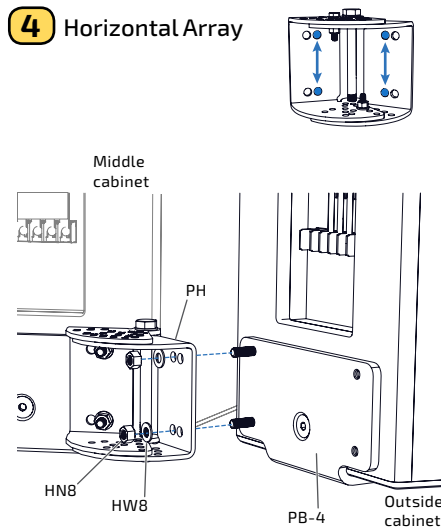

Figure 24-4H (Horizontal Array). Remove the 6mm hardware and connect the hinge assemblies to the cabinet brackets (build from the inside-out)

5 Horizontal Array

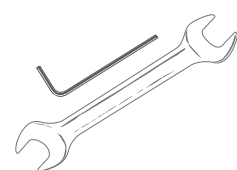

Figure 24-5H. Fully tighten all cabinet and hinge-to-bracket connections

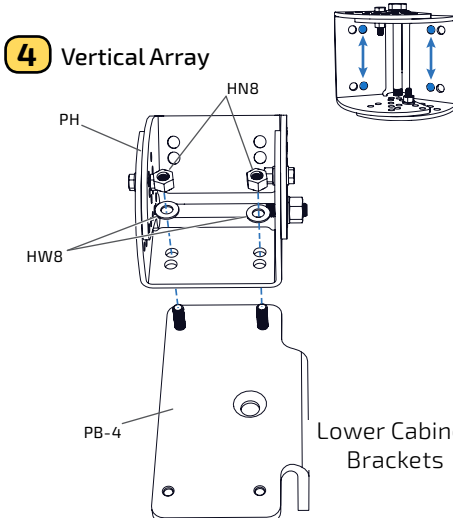
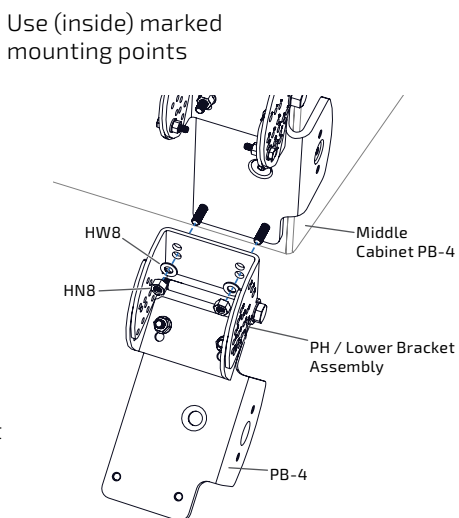

Figure 24-4V (Vertical Array). Remove the 6mm hardware from the hinges and attaching the lower cabinet brackets to the hinge assemblies, and then to the cabinet brackets on the suspended cabinet (build from the top > down)



5 Vertical Array

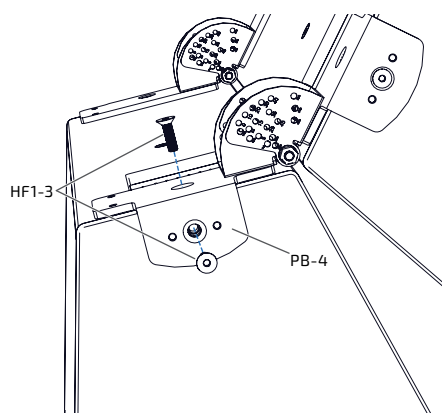

Figure 24-5V (Vertical Array). Lift the cabinet up and attach it to the cabinet brackets - tighten all hinge and cabinet connections

6 ARRAY ACCESSORIES

HVS3 (continued)

6 Horizontal Array

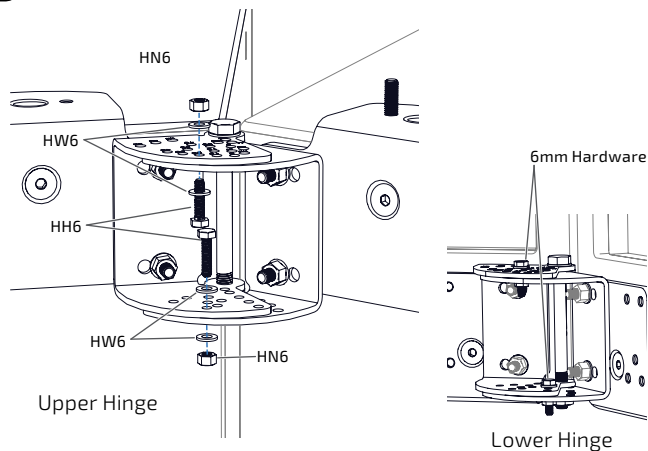

Figure 24-6H. Secure angle on hinges by reinserting the 6mm hardware removed earlier
Snug tighten the 6mm connections until desired angle is confirmed, then fully tighten

6 Vertical Array

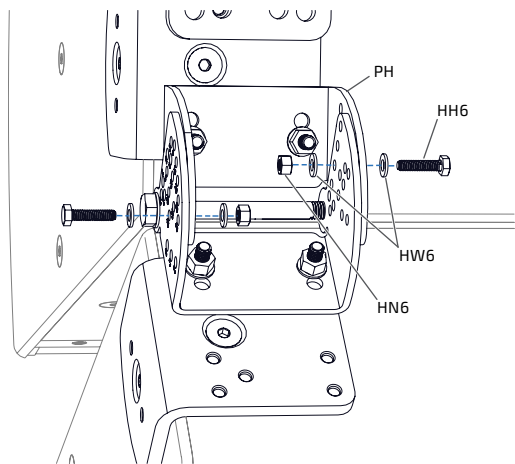
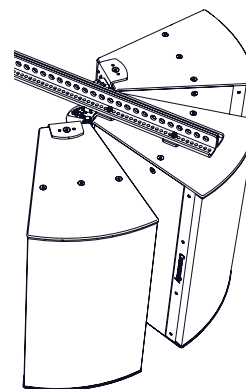

Figure 24-6V. Adjust hinge to desired angle and reinsert the 6mm hardware
Snug tighten the 6mm connections until desired angle is confirmed, then fully tighten

Triple horizontal full-range 3-way array can be accomplished in two ways: HSB3-BFR22 / HSB3-SBR54 + (1) HVS3 kit or BFR22V / SBR54 + (2) HVS3 kits.

Remove (2) 8mm flat head bolts from the PP-2 (or PP-1) and thread them into the top of what will be the middle cabinet top bracket. Attach all cabinet brackets and mounting plates to the cabinets. Attach the hinges. Attach the rails and fully tighten all rail and cabinet connections. Set the angles on the hinges - they must be symmetrical to balance evenly.



The PP-2 splay adapter plate will not be used, and there will be hardware and a few parts left over.

7

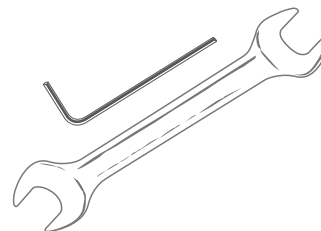

Figure 24-7. Fully tighten all connections

6 ARRAY ACCESSORIES

TPK - Tight Pack Kit

APPLICATION: Connect two like-sized subwoofers or loudspeakers that share common suspension points

ASSEMBLY:

Place two cabinets side by side (same orientation) and remove the applicable flat head bolts.

Place the mounting plates to tie the two cabinets together and thread the supplied flat head bolts through the plates and into the cabinets (Figure 17a). Fully tighten the connections without crushing any wood fibers. Repeat for other side.

Best Practices: If the mounting plate is on an edge, orient the plate so that the flat side is against the edge.

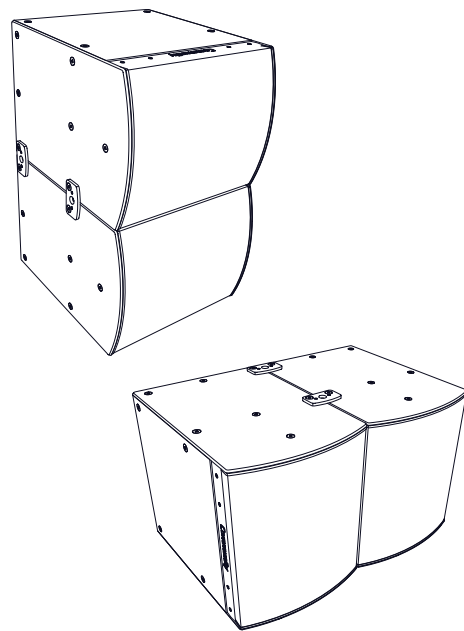

Parts:



PP-1

PP-1 Universal Mounting Plates (4)
Gasket Material

Hardware:

Qty	Code	Description
8	HF1-3	10 x 35 mm Flat Hd Bolts

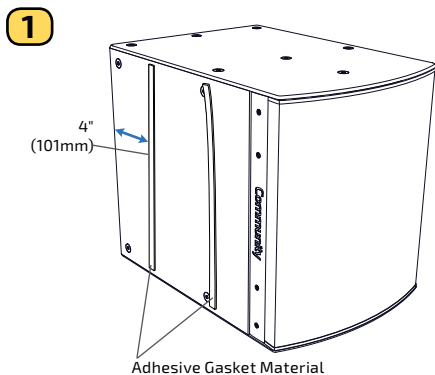

Figure 26-1. Cut and adhere (2) strips of gasket to the side of one subwoofer (spanning the height and spaced equidistant)

Additional configuration :

(Horizontal orientation is suggested since there is only 1 connection per side):

IS6/8-212 SUB + IP6/8-1122 2-WAY

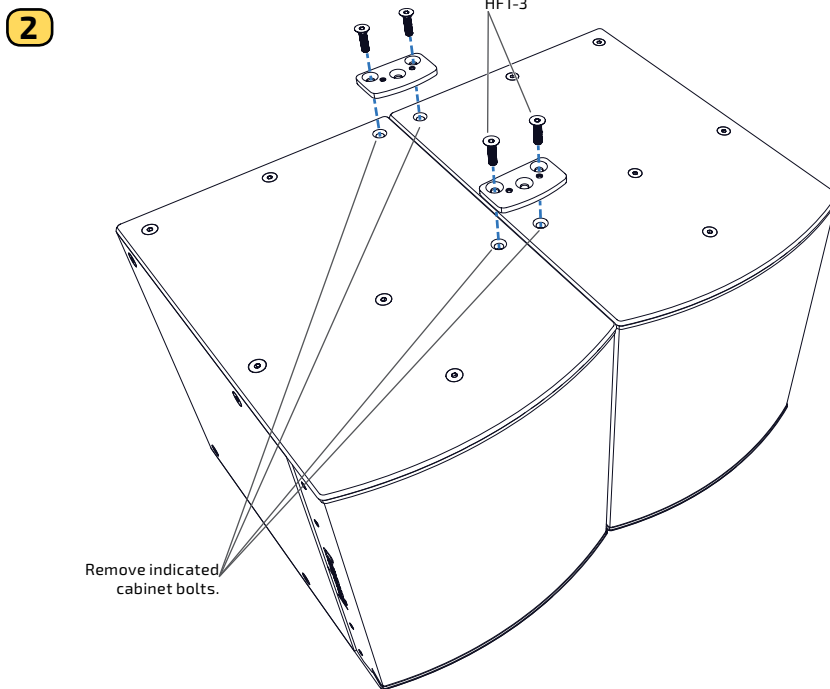
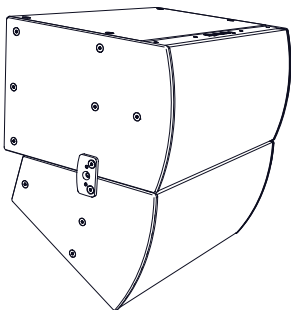
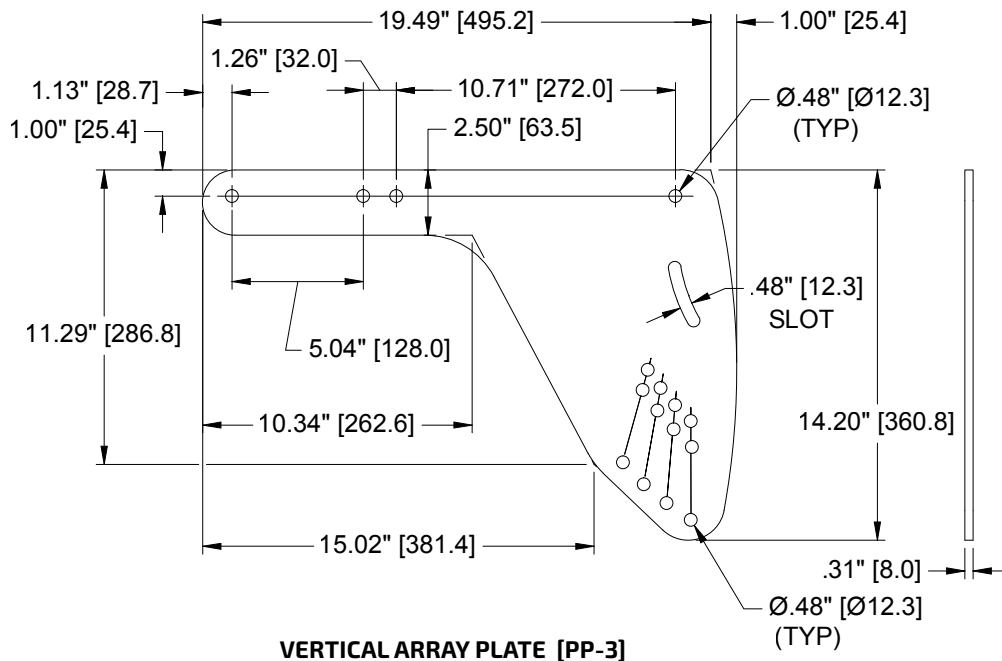
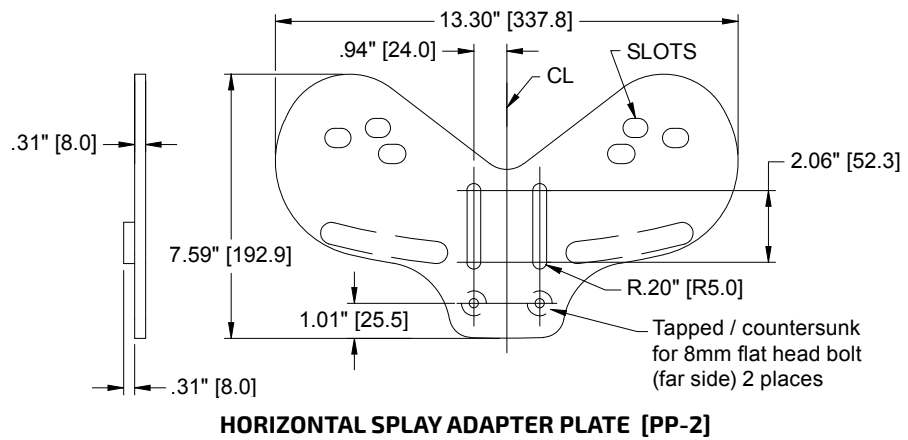
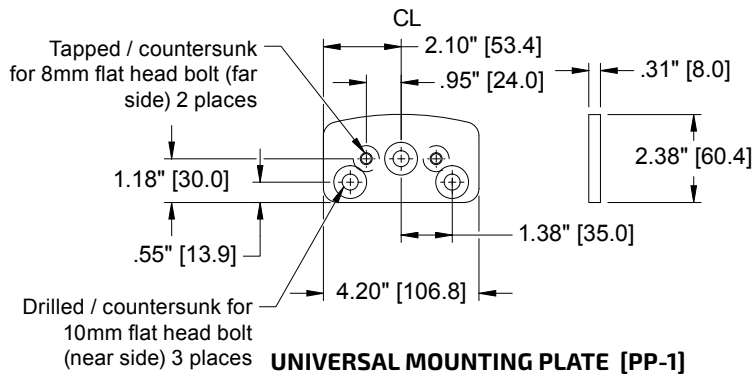
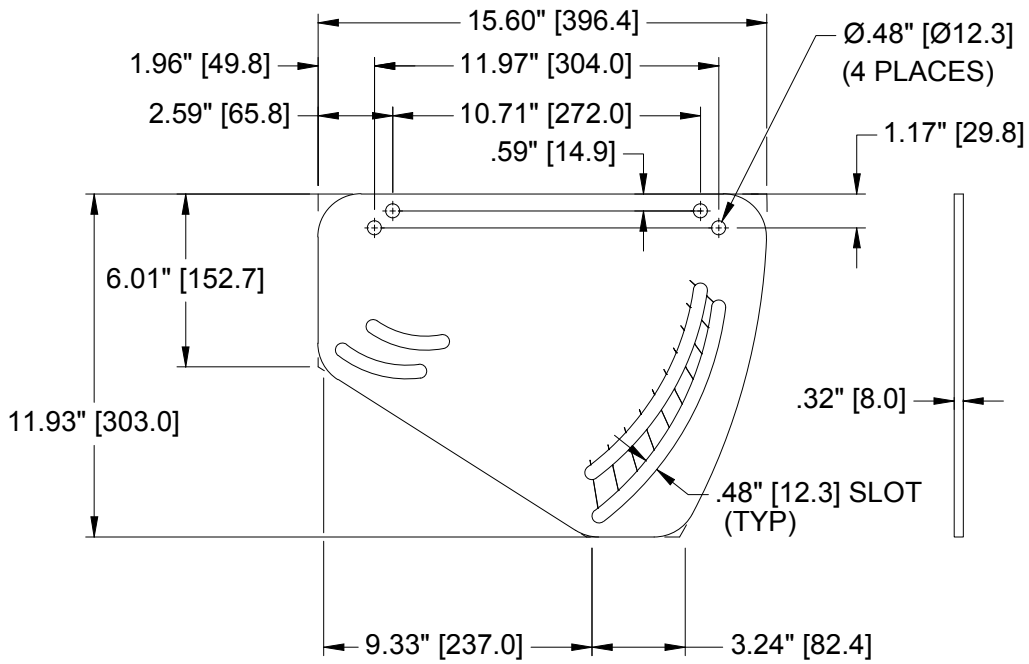

Figure 26-2. With the gasket sandwiched between the cabinets, attach the mounting plates to the cabinets - two to a side

7 PARTS - PLATES



7 PARTS - PLATES (CONTINUED)



HORIZONTAL ARRAY PLATE (2-WAY) [PP-4]

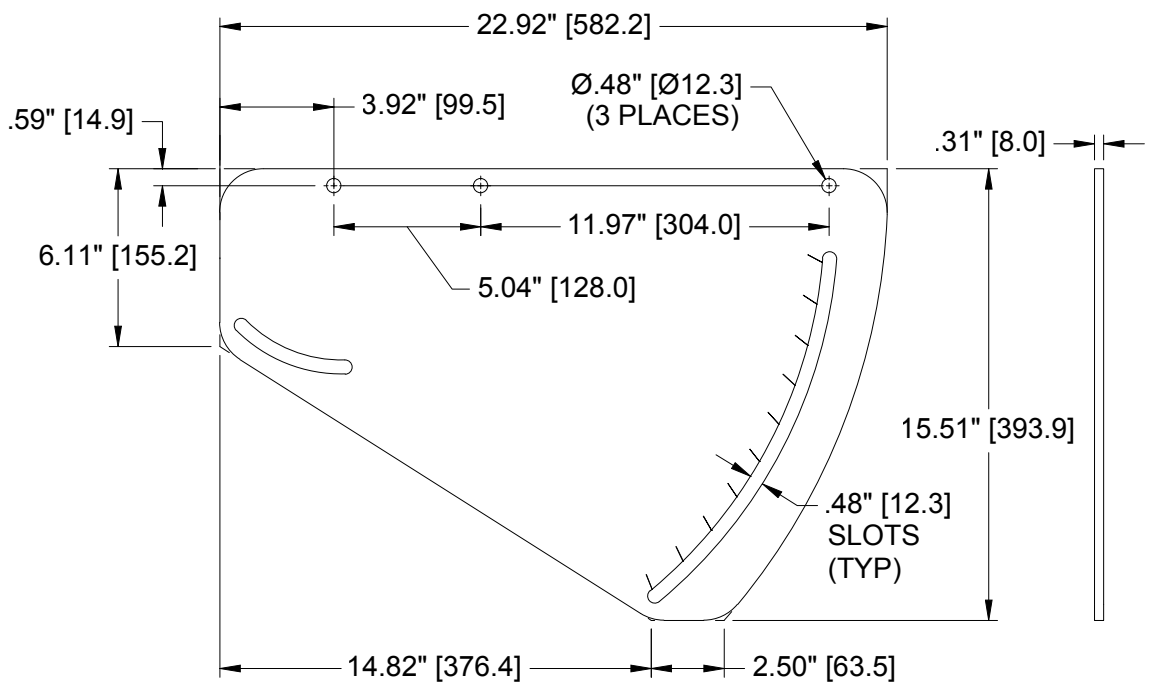

HORIZONTAL ARRAY PLATE (3-WAY) [PP-5]

7 PARTS - BRACKETS

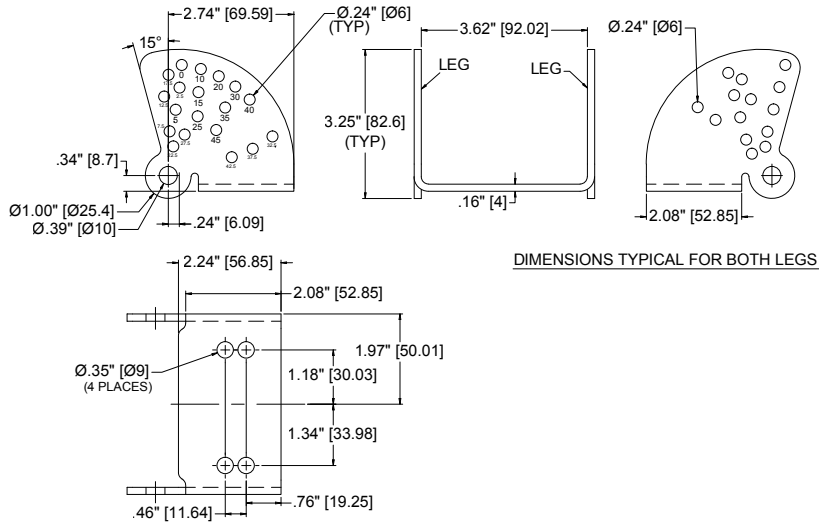

HINGE (ROTATIONAL ARRAY) BRACKET [PH]

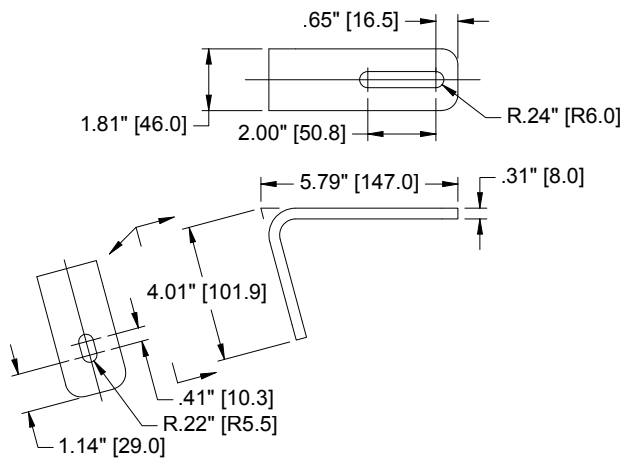

L BRACKET (SINGLE) [PB-1]

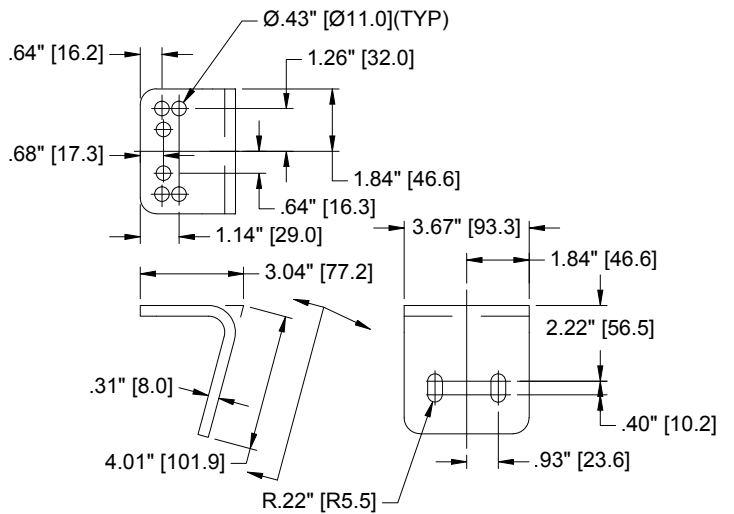

L BRACKET (DOUBLE) [PB-2]

7 PARTS - BRACKETS (CONTINUED)

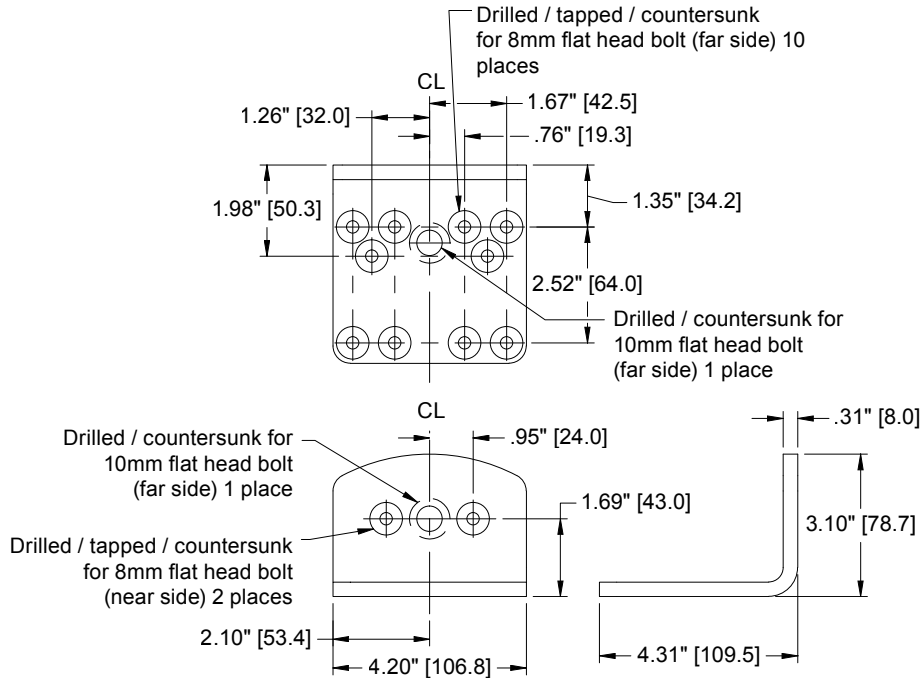

CABINET CORNER BRACKET (2-WAY) [PB-3]

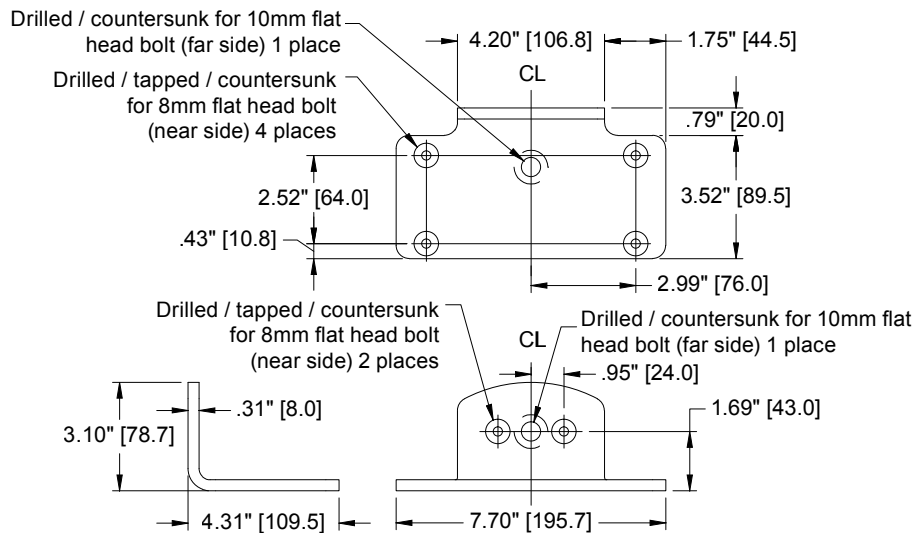

CABINET CORNER BRACKET (3-WAY) [PB-4]

7 PARTS - BALANCEPOINT™ FLY RAILS

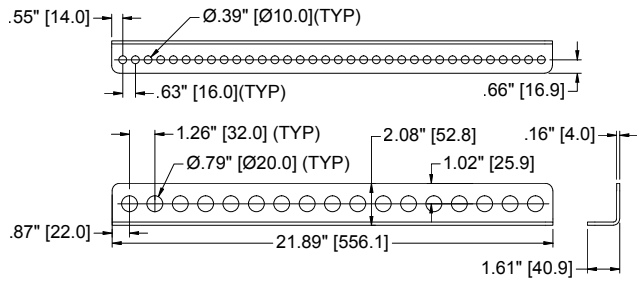

22" BALANCEPOINT™ FLY RAILS [PR-1]

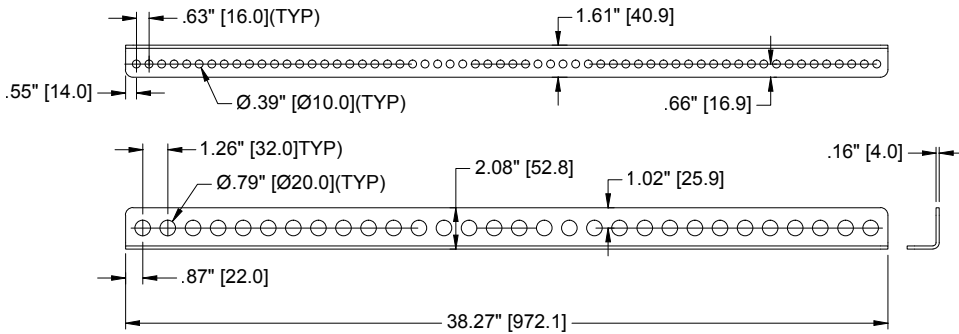

38" BALANCEPOINT™ FLY RAILS [PR-2]

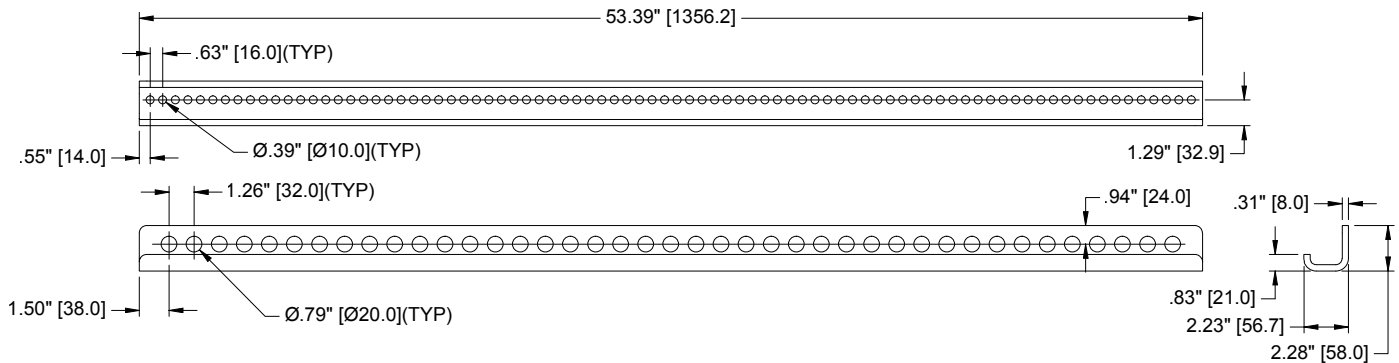

54" BALANCEPOINT™ FLY RAILS [PR-3]

7 PARTS - U-BRACKETS

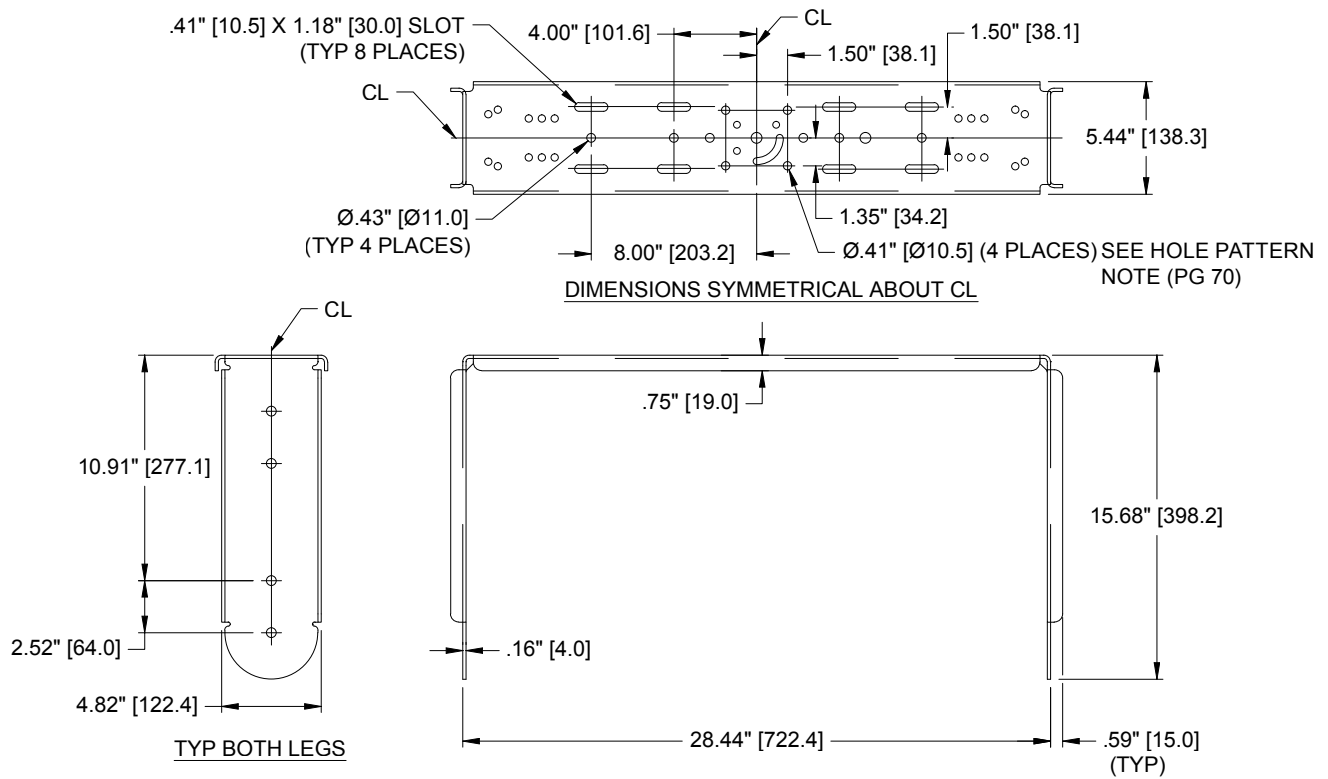

IUB1122 - U-BRACKET FOR IP6-1122 AND IP8-1122 MODELS

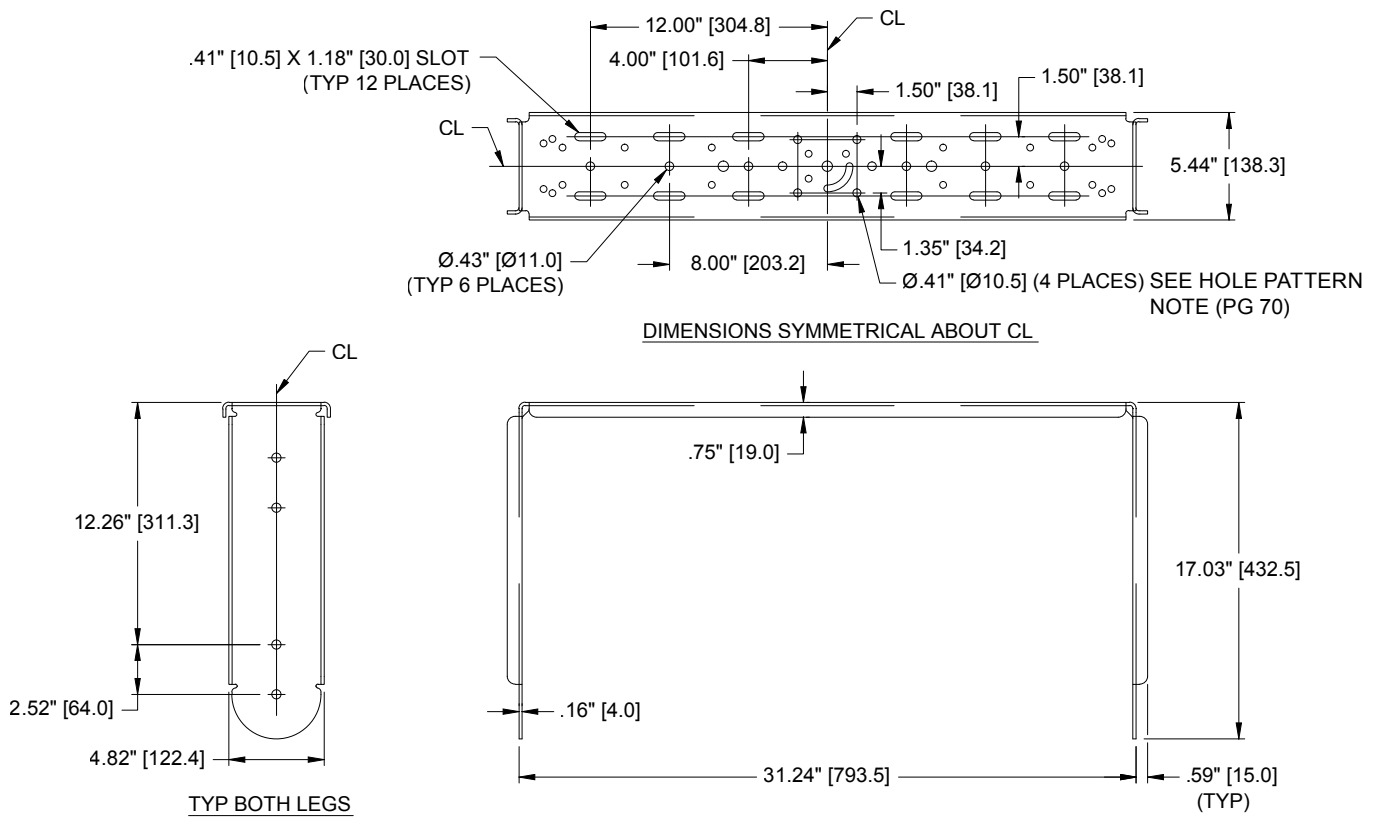

IUB1152 - U-BRACKET FOR IP6-1152 AND IP8-1152 MODELS

7 PARTS - U-BRACKETS (CONTINUED)

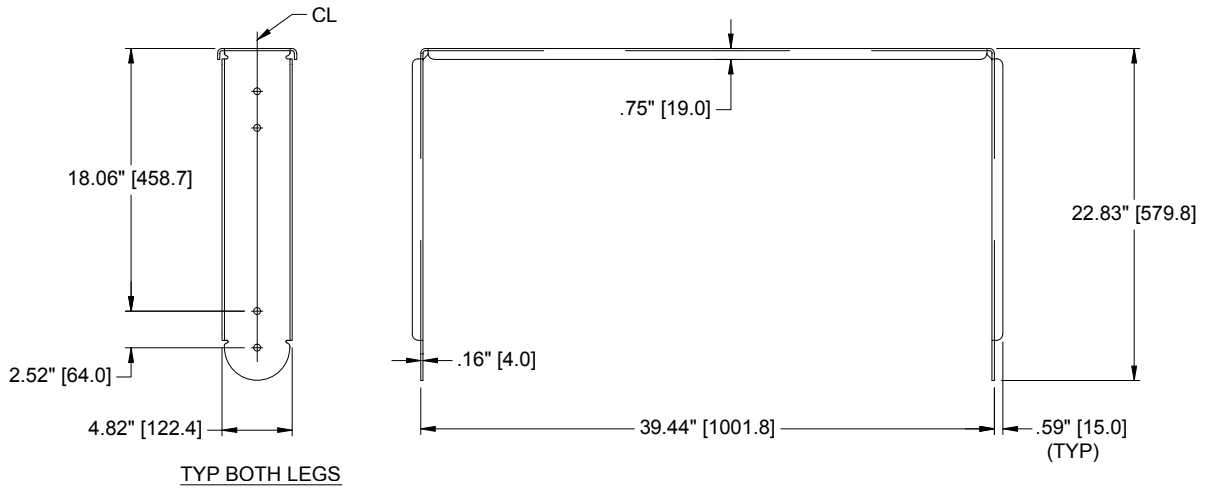
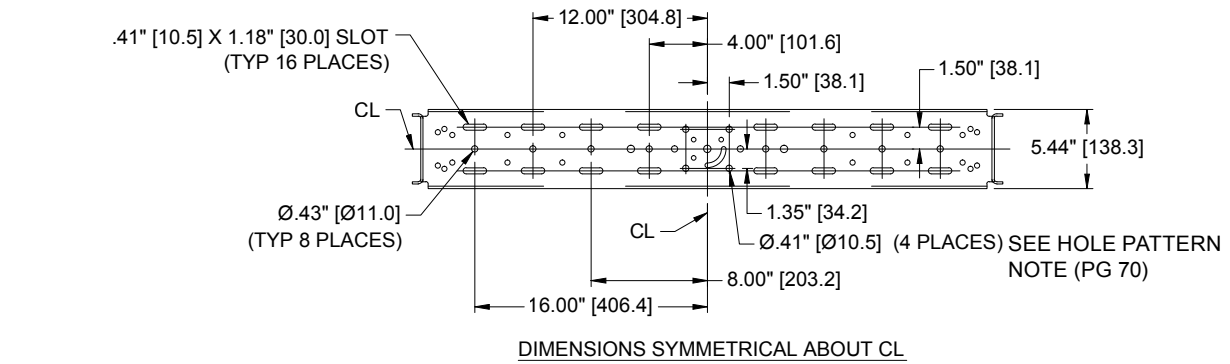

IUB1153 - U-BRACKET FOR IP8-1153 MODELS

7 PARTS - VERTICAL YOKES

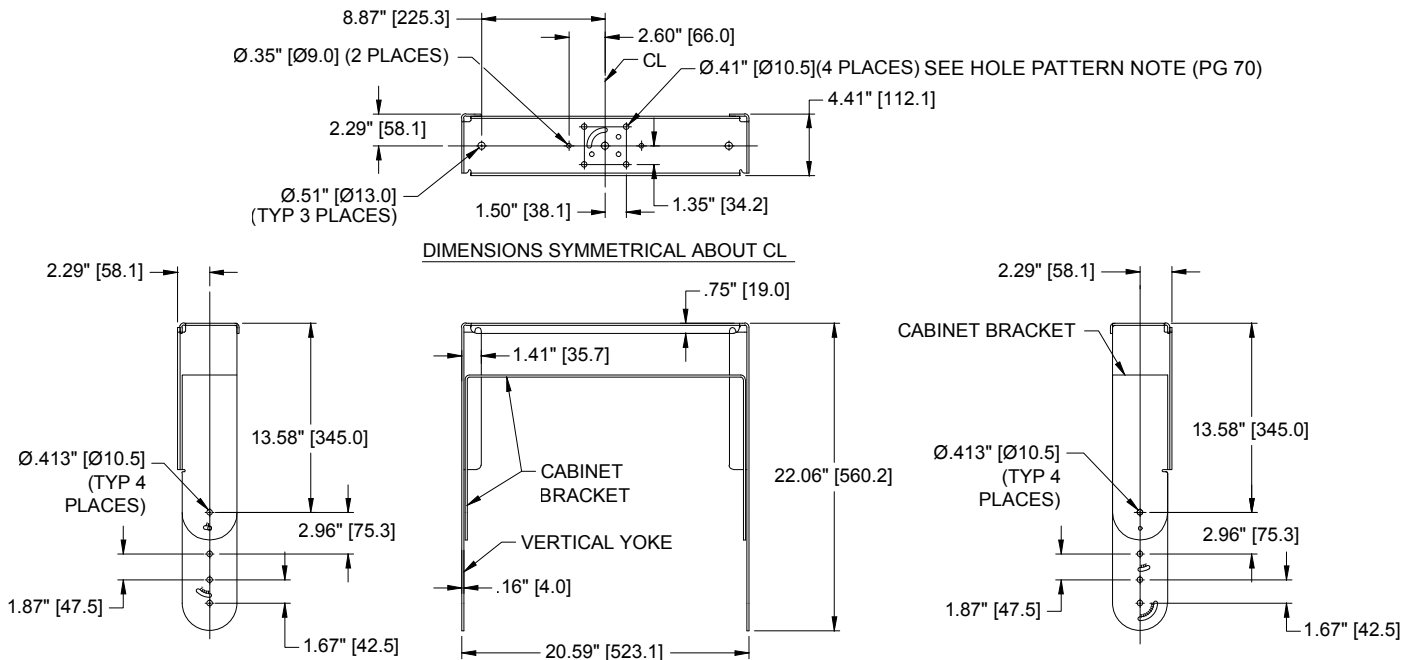

IVY0002 - VERTICAL YOKE FOR IP8-0002 AND IP8-1151 MODELS

7 PARTS - VERTICAL YOKES (CONTINUED)

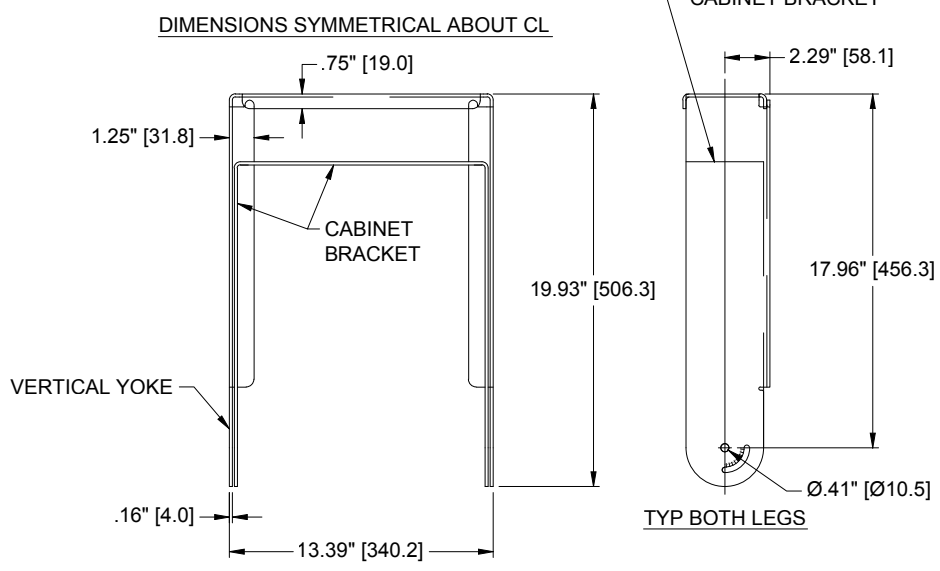
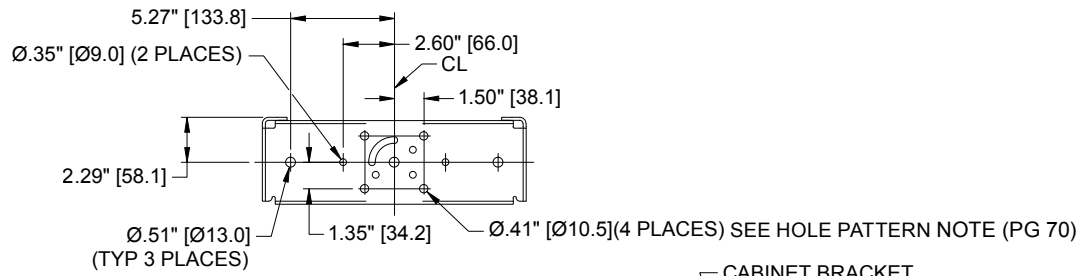

IVY1122 - VERTICAL YOKE FOR IP6-1122 AND IP8-1122 MODELS

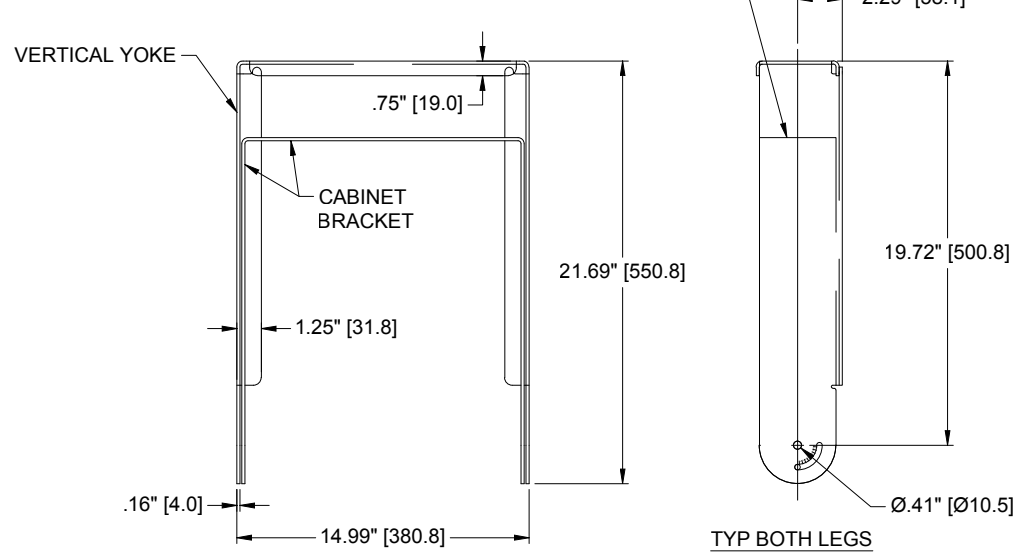
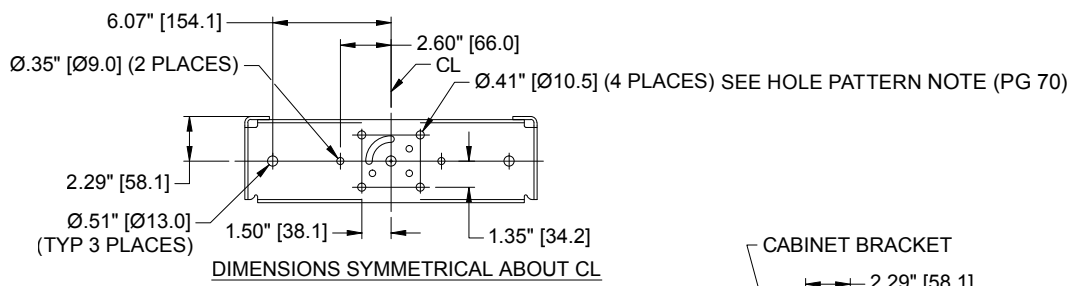

IVY1152 - VERTICAL YOKE FOR IP6-1152 AND IP8-1152 MODELS

7 PARTS - VERTICAL YOKE (CONTINUED)

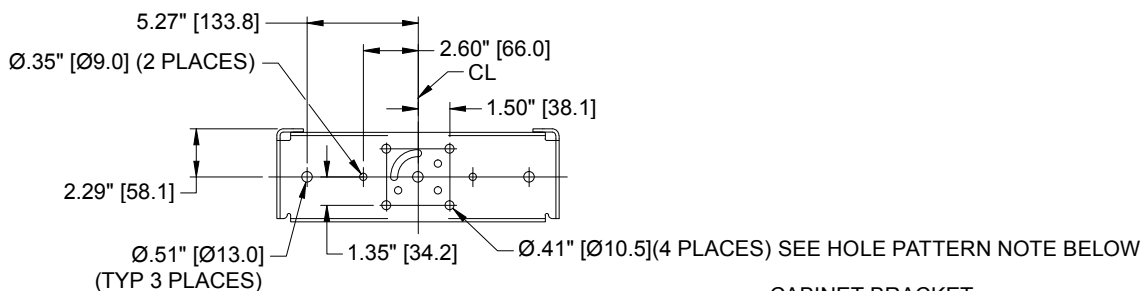

DIMENSIONS SYMMETRICAL ABOUT CL

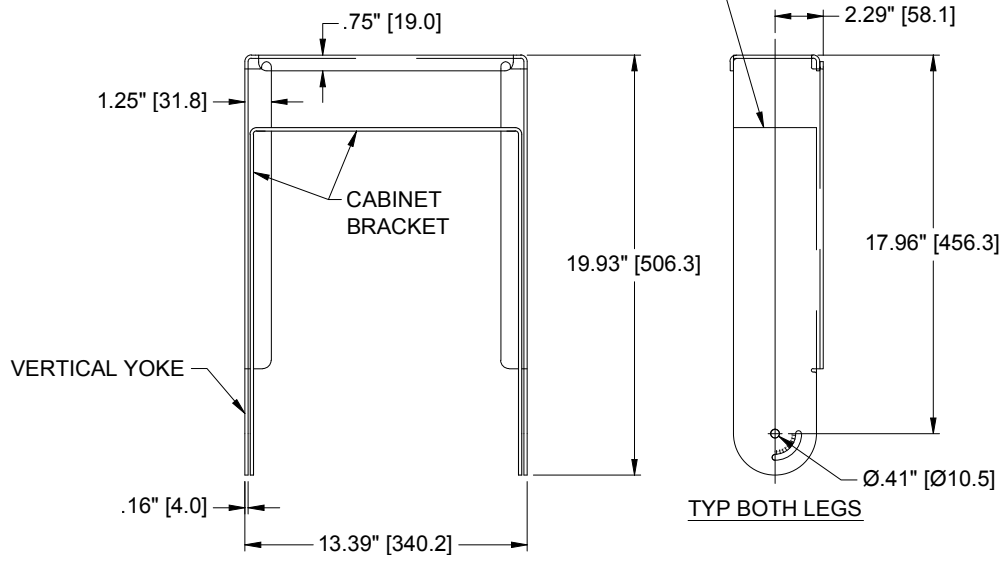

IVY1153 - VERTICAL YOKE FOR IP8-1153 MODELS

Hole Pattern Note: Hole pattern compatible with Chief CMA105 UL listed Ceiling mount adapter plates for use with the manufacturer's respective 1-1/2" NPT rigid pole mounting systems. See manufacturer's website for mounting details and limitations.

7 PARTS - ARRAY FRAMES

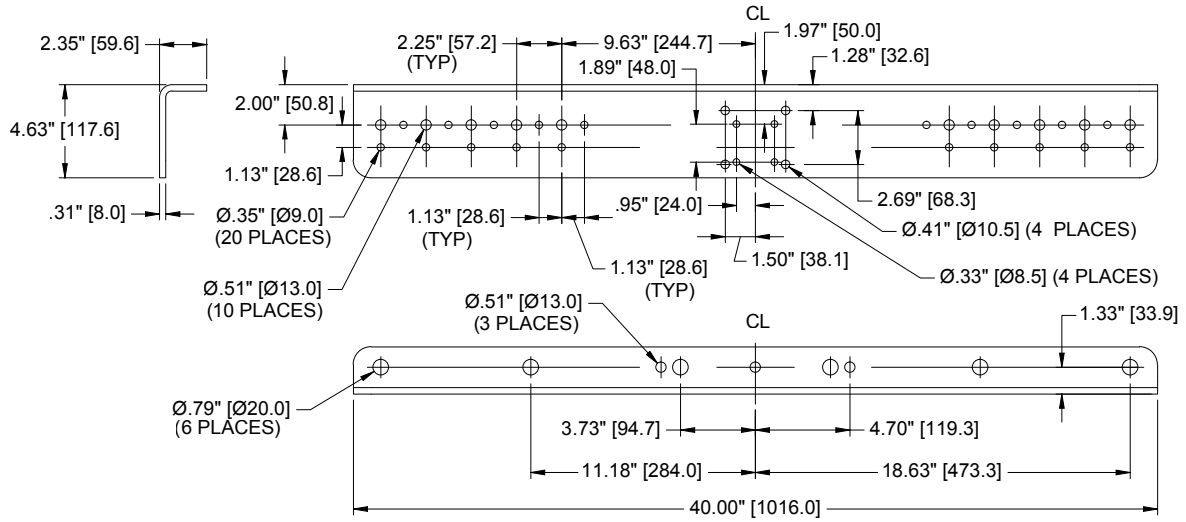

ARRAY FRAME (40") [PF-1A]

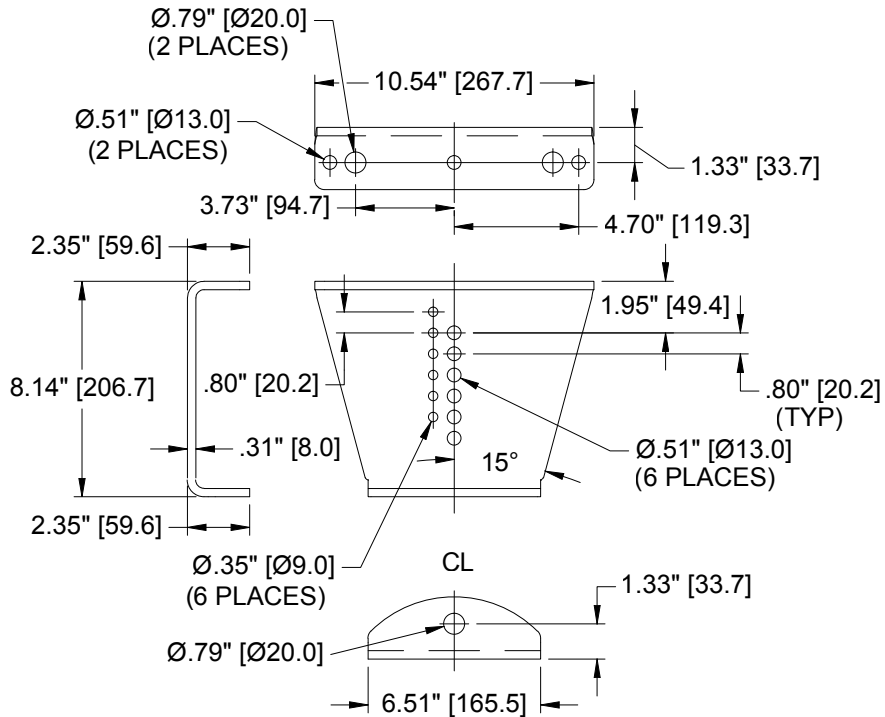

ARRAY FRAME BRACKET (40") [PF-1B]

7 PARTS - ARRAY FRAMES (CONTINUED)

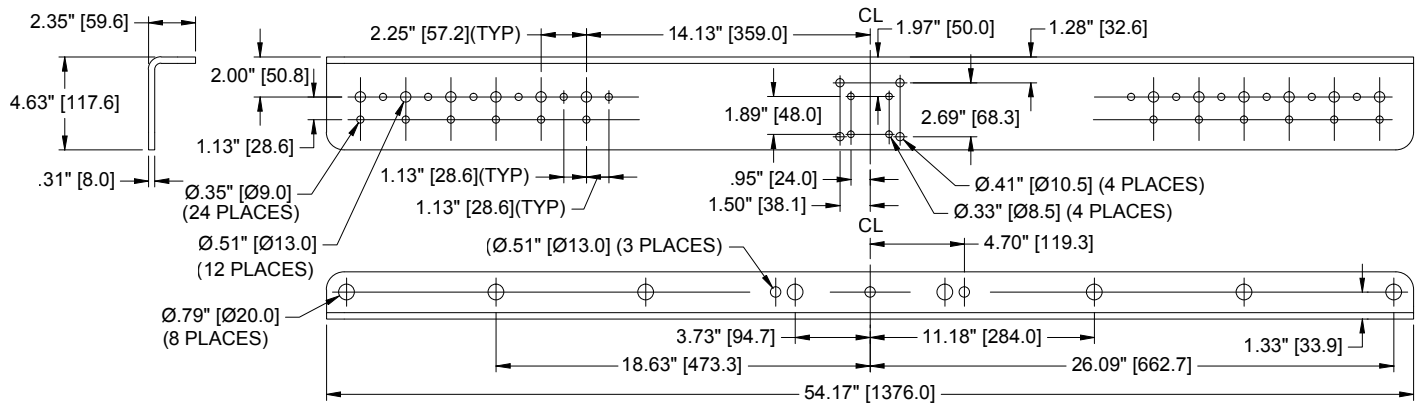

ARRAY FRAME (55") [PF-2A]

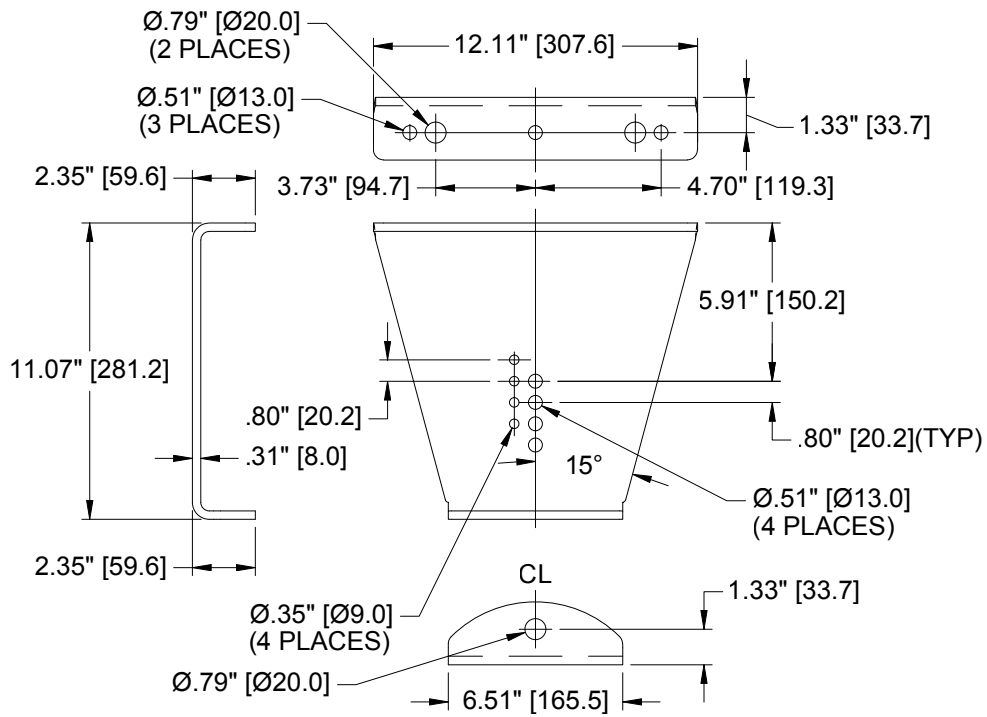

ARRAY FRAME BRACKET (55") [PF-2B]

8 ADVANCED ARRAY CONFIGURATIONS

Some kits may be combined to create larger combinations. The kit weights are provided and the loudspeaker weight is on their spec sheets (available on the Community website (www.communitypro.com)). Please also note that **we recommend no more than three (3) full-range loudspeakers and two (2) subwoofers per combined assembly**. More than this number will exceed the safe working load limit. An adequate number of hang points must also be chosen to avoid placing stress or possible torque on connections.

! IMPORTANT: Please have a registered structural engineer review and approve any combined assemblies.

Some of the views shown below have two subwoofers attached to the rails. The same type of configuration can be made with just one (1) subwoofer.

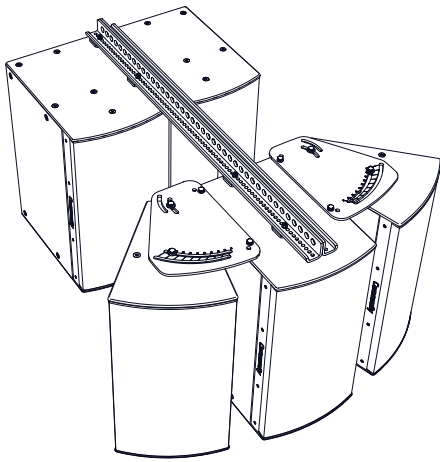

HAB-BFR38 + SBR54
2 x IP6/8-1122 and 3 x IS6/8-212
(substitutes the 54" rails for the 38")

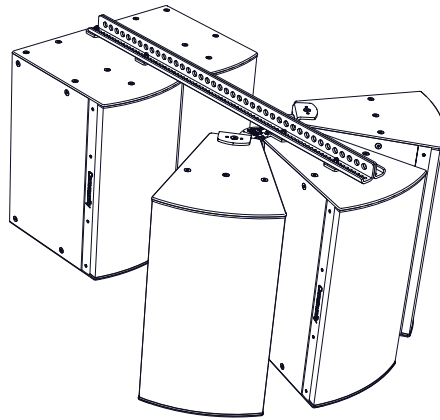

HSB-SBR54 + HVS + TPK
3 x IP6/8-1122 and 2 x IS6/8-212

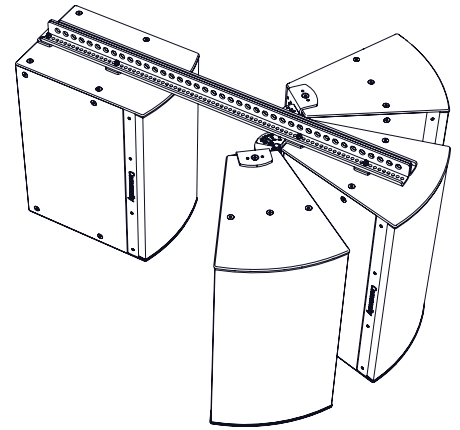

SBR54 + (2) HVS
3 x IP6/8-1122 and 1 x IS6/8-212

Low Profile Option

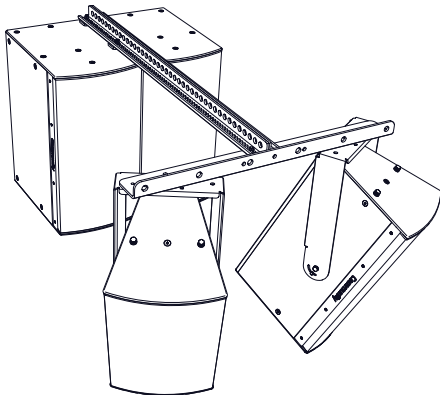

IAF40 + (2x)IVY1122 + SBR54
2 x IP6/8-1122 and 2 x IS6/8-212

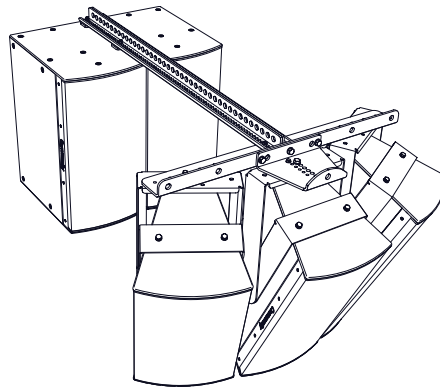

IAF40 + (3x)IVY1122 + SBR54
3 x IP6/8-1122 and 2 x IS6/8-212

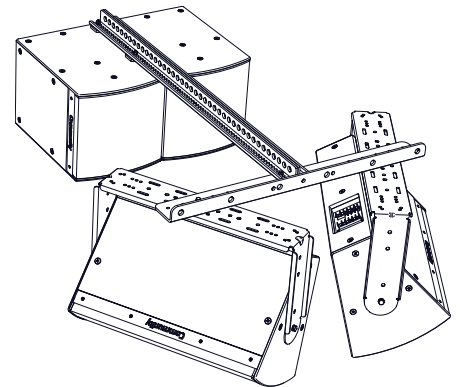

IAF40 + (2x)IUB1122 + SBR54
2 x IP6/8-1122 and 2 x IS6/8-112

8 ADVANCED ARRAY CONFIGURATIONS (CONTINUED)

EXPANDED ARRAYS

Additional loudspeakers played vertically

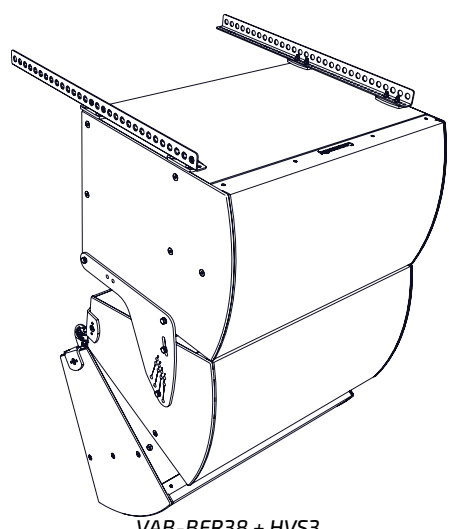

VAB-BFR38 + HVS3
 2 x IP8-1153 and 1 x IS6/8-218 (or IS6/8-215)
 not shown - smaller configuration
VAB-BFR38 + HVS
 2 x IP6/8-1122 and 1 x IS6/8-212

Additional subwoofers behind arrays for cardioid or steered bass

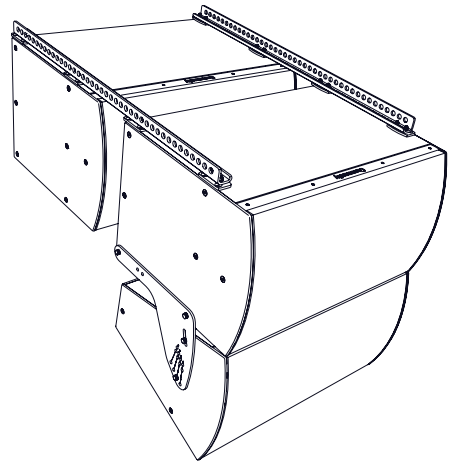

VAB-BFR38 + SBR54
 1 x IP8-1153 and 2 x IS6/8-218
 (or 1 x IP8-1153 and 2 x IS6/8-215)

Combine a subwoofer with any U-Bracket

Low Profile Option

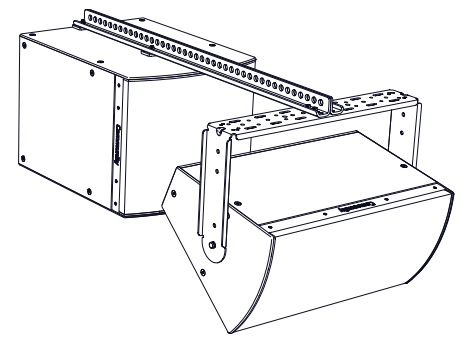

IUB1122 + SBR54
 IP6/8-1122 and IS6/8-112

Combine any subwoofer with any Vertical Yoke

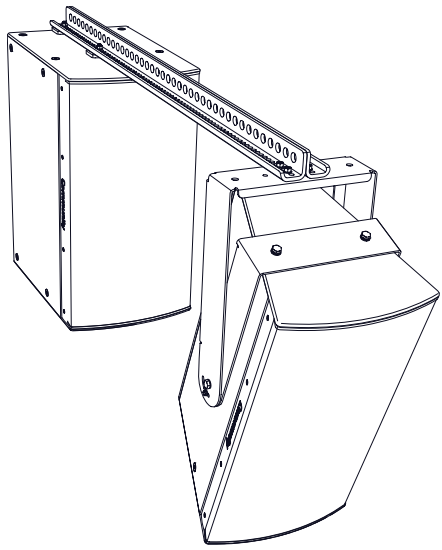

IVY1122 + SBR54
 IP6/8-1122 and IS6/8-212

Add another to a horizontally oriented subwoofer with a Tight Pack kit (TPK).

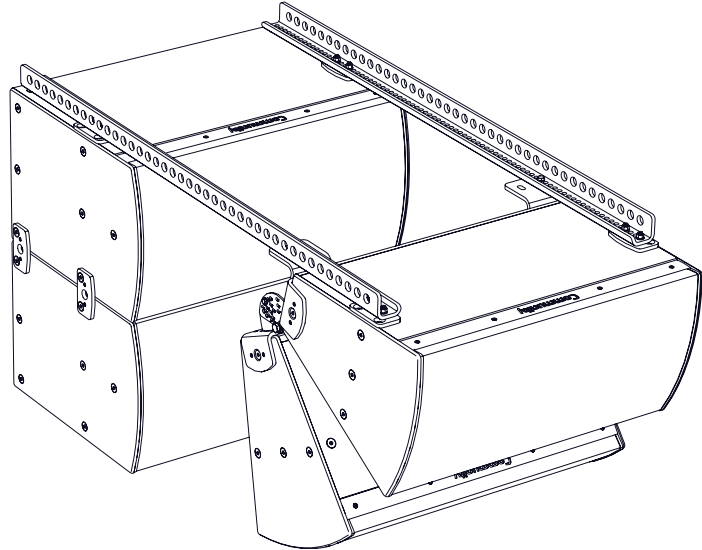

VSB-SBR54 + TPK
 2 x IP6/8-1122 and 2 x IS6/8-212

WARNING: Do NOT exceed three (3) full-range cabinets and two (2) subwoofers in a single connected array. More will exceed the maximum safe working load.

8 WARRANTY

All I SERIES mounting kits are covered by a limited warranty for a period of five (5) years. Please go to communitypro.com/warranty for complete information.

KIT WEIGHTS (includes parts and hardware, no packaging)

KIT NAME	DESCRIPTION	lbs	kg
BFR22H	22" BALANCEPOINT™ FLY RAILS HORIZONTAL	12.0	5.4
BFR22V	22" BALANCEPOINT™ FLY RAILS VERTICAL	9.0	4.1
DFS	DOWNFILL SPLAY BRACKET KIT	10.0	4.5
DVS-BFR22	DUAL VERTICAL SPLAY KIT FOR TWO VERTICAL I SERIES ENCLOSURES	17.0	7.7
HAB-BFR38	DUAL HORIZONTAL ARRAY KIT FOR 2-WAY I SERIES MODELS	40.0	18.1
HAB3-BFR38	DUAL HORIZONTAL ARRAY KIT FOR 3-WAY I SERIES MODELS	58.0	26.3
HSB-BFR22	DUAL HORIZONTAL SPLAY KIT FOR 2-WAY I SERIES MODELS	25.0	11.3
HSB3-BFR22	DUAL HORIZONTAL SPLAY KIT FOR 3-WAY I SERIES MODELS	31.0	14.1
HSB-SBR54	DUAL HORIZONTAL SPLAY WITH EXTENSION KIT FOR 2-WAY I SERIES MODELS	32.0	14.5
HSB3-SBR54	DUAL HORIZONTAL SPLAY WITH EXTENSION KIT FOR 3-WAY I SERIES MODELS	42.0	19.1
HVS	H/V SPLAY BRACKET EXTENSION KIT FOR 2-WAY I SERIES MODELS	15.0	6.8
HVS3	H/V SPLAY BRACKET EXTENSION KIT FOR 3-WAY I SERIES MODELS	22.0	10.0
IAF40	40" ISOMETRIC ARRAY FRAME	33.0	15.0
IAF55	55" ISOMETRIC ARRAY FRAME	44.0	20.0
IUB1122	U-BRACKET FOR IP6/8-1122	16.0	7.3
IUB1152	U-BRACKET FOR IP6/8-1152	17.0	7.7
IUB1153	U-BRACKET FOR IP8-1153	22.0	10.0
IVY0002	VERTICAL YOKE FOR IP8-0002, IP8-1151	23.0	10.4
IVY1122	VERTICAL YOKE FOR IP6/8-1122	21.0	9.5
IVY1152	VERTICAL YOKE FOR IP6/8-1152	23.0	10.4
IVY1153	VERTICAL YOKE FOR IP8-1153	25.0	11.3
SBR54	SUBWOOFER BEHIND BALANCEPOINT FLY RAILS (54")	20.0	9.1
TPK	TIGHT PACK KIT	4.0	1.8
VAB-BFR38	SUBWOOFER ABOVE FULL-RANGE VERTICAL ARRAY	36.0	16.3
VSB-BFR22	DUAL VERTICAL SPLAY KIT FOR 2-WAY I SERIES MODELS	27.0	12.2
VSB3-BFR22	DUAL VERTICAL SPLAY KIT FOR 3-WAY I SERIES MODELS	32.0	14.5
VSB-SBR54	DUAL VERTICAL SPLAY WITH EXTENSION KIT FOR 2-WAY I SERIES MODELS	37.0	16.8
VSB3-SBR54	DUAL VERTICAL SPLAY WITH EXTENSION KIT FOR 3-WAY I SERIES MODELS	43.0	19.5

LOUDSPEAKER WEIGHTS

FULL-RANGE	600 Level [lbs (kg)]	800 Level [lbs (kg)]	SUBWOOFER	600 Level [lbs (kg)]	800 Level [lbs (kg)]
IP6/8-1122	65.0 (29.5)	55.0 (24.9)	IP6/8-112	64.0 (29.0)	58.0 (26.3)
IP6/8-1152	79.0 (35.8)	68.0 (30.8)	IP6/8-115	78.0 (35.4)	72.0 (32.7)
IP8-1153	-	105.0 (47.6)	IP6/8-118	97.0 (44.0)	98.0 (44.5)
IP8-0002	-	63.0 (28.6)	IP6/8-212	101.0 (45.8)	89.0 (40.4)
IP8-1151	-	54.0 (24.5)	IP6/8-215	126.0 (57.2)	14.0 (51.7)
			IP6/8-218	170.0 (77.1)	172.0 (78.0)



I SERIES

BalancePoint™ Flyware Accessory Guide

For Point Source and Subwoofer
loudspeakers models IP8, IP6, IS8, and IS6